

READ AND SAVE THESE INSTRUCTIONS

This manual must be left with the owner and should be accessible for reference.

# Controls for DRI-STEEM Models GTS<sup>TM</sup> and GTS-DI<sup>TM</sup> GAS-TO-STEAM HUMIDIFIERS

**User's/Installation Instructions  
and  
Maintenance Operations Manual**

**For Toll-Free Customer Support,  
Call: 1-800-328-4447**



**DRI-STEEM<sup>®</sup>**  
HUMIDIFIER COMPANY



---

# TABLE OF CONTENTS

---

## TO THE PURCHASER AND THE INSTALLER

Thank you for purchasing DRI-STEEM Model GTS™ equipment. We have designed and built this equipment to give you total satisfaction and many years of trouble-free service. Proper installation and operating practices will assure you of achieving that objective. We therefore urge you to become familiar with the contents of this manual.

DRI-STEEM Humidifier Company

<b>Models GTS and GTS-DI Humidifiers .....</b>	<b>3</b>
<b>Safety Precautions .....</b>	<b>4</b>
<b>Installation</b>	
GTS Humidifier .....	5
GTS Control Box Field Wiring .....	5
Zone Terminal Unit .....	6
<b>GTS Operation .....</b>	<b>7</b>
<b>Multiple-Tank GTS Operation .....</b>	<b>8</b>
<b>Programming of the Zone Terminal Control Unit</b>	
PI Loop Control .....	9
Humidistat Control .....	10
Control by Others .....	10
Humidifier Operation .....	10
Zone Terminal Control Unit .....	10
Keys .....	11
Parameters .....	11
Error Codes .....	13
Status Points .....	14
<b>Operation of the Johnson Metasys® UNT Controller</b>	
Water Level Control .....	15
Drain and Flush Cycle .....	15
Skim Time .....	15
End of Season Drain .....	15
Faults and Alarms .....	16
<b>Startup .....</b>	<b>17</b>
<b>Sample of GTS Wiring Diagrams .....</b>	<b>18</b>
<b>Trouble-Shooting Guide .....</b>	<b>22</b>
<b>Two-Year Limited Warranty .....</b>	<b>24</b>

## MODELS GTS™ AND GTS-DI HUMIDIFIERS

### Model GTS Gas-to-Steam Humidifier

This humidifier is designed to be used with either softened or unsoftened water (preferably softened). The probe-type level control system requires water conductivity of 100 micromhos/cm (2 grains/gal) minimum to function, and therefore will not operate on water treated by reverse osmosis or deionization. However, GTS humidifiers are available for use with these water types. The standard humidifier can be converted in the field to a demineralized model. See below.

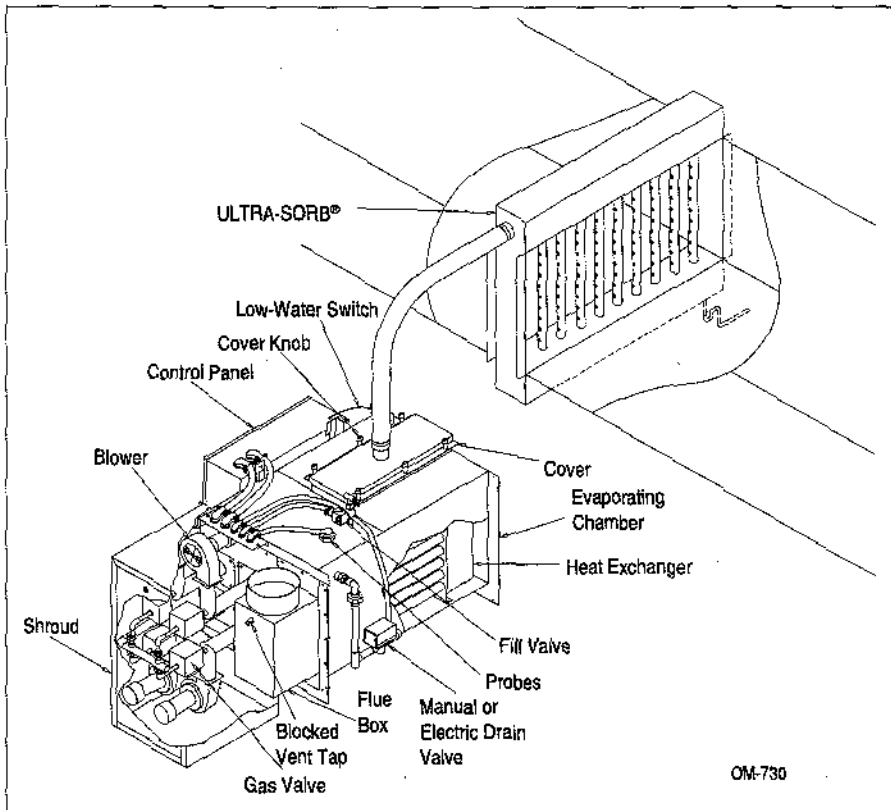

### Model GTS-DI Option

For use with deionized or reverse osmosis water. This unit produces chemical-free steam and reliable, accurate humidification control. It is virtually maintenance-free, with no wasted water, heat, or downtime.

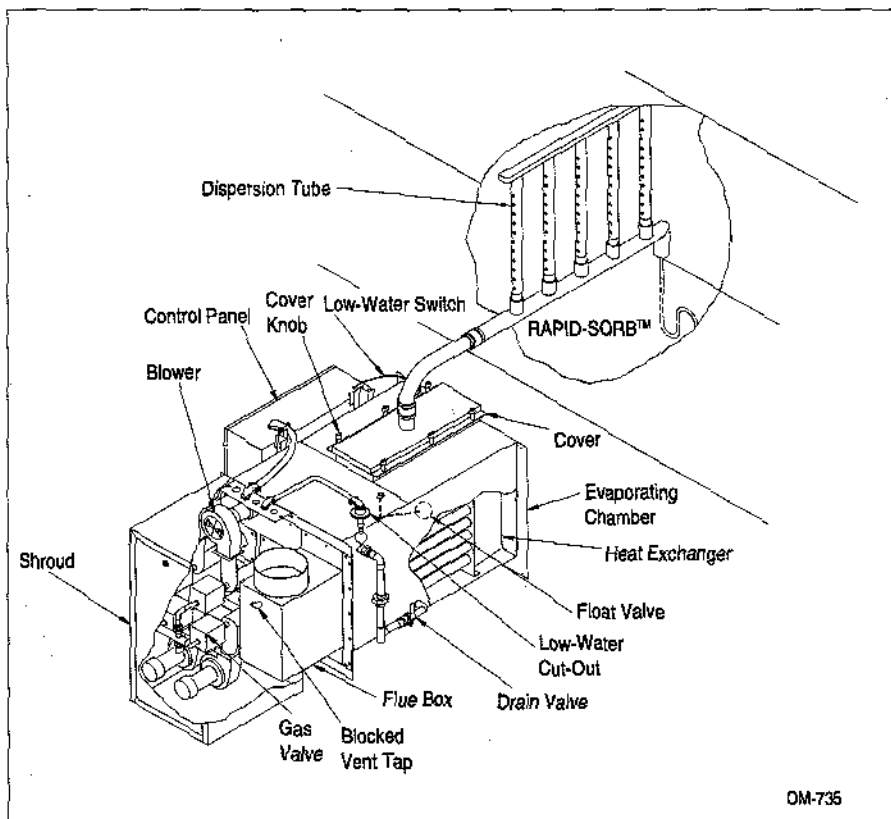

---

## SAFETY PRECAUTIONS

---

### WARNING:

Improper installation, adjustment, alteration, service, maintenance, or use can cause carbon monoxide poisoning, an explosion, fire, electrical shock, or other conditions which may cause personal injury or property damage. Consult a qualified installer, service agency, local gas supplier, or your distributor or branch for information or assistance. The qualified installer or agency must use only factory authorized and listed kits or accessories when modifying this product. A failure to follow this warning can cause electrical shock, fire, personal injury, or death.

- Inspect humidifier and accessories upon arrival for damaged, missing, or improper parts. If there is a problem, call DRI-STEEM.
- Application of this humidifier should have special attention given to vent sizing and material, gas input rate, and unit sizing. Improper installation or misapplication of the humidifier can require excessive servicing or cause permanent component failure.

- When working on equipment, observe precautions in this literature, tags, and labels attached to or shipped with the unit and other safety precautions that may apply. Wear safety glasses and work gloves. Have fire extinguisher available during start-up, adjustment procedures, and service calls.

- Do not use this appliance if any part has been under water. Immediately call a qualified service technician to inspect the appliance and to replace any part of the control system and any gas control which has been under water.

- Do not lift humidifier by gas controls, gas manifold, flue box, or control shroud.

- Should overheating occur, or the gas supply fail to shut off, shut off the manual gas valve to the appliance before shutting off the electrical supply.

# INSTALLATION

## General

This booklet covers only the controls associated with the GTS™ Humidifier installation.

Refer to the wiring diagrams that is provided with the equipment to determine if any special features or wiring have been incorporated as required for your application.

## GTS Humidifier

It is a necessity that the GTS humidifier itself has previously been installed in accordance with the User's/ Installation Instructions and Maintenance Operations Manual that was shipped with the equipment.

## GTS Control Box Field Wiring

When the GTS was installed, the electrical power supply connections should have been made to the bottom of the control cabinet that is located at the left side of the GTS humidifier.

This cabinet also contains the connection points for other low voltage field connections that are required. These may include the humidity transmitter, high limit humidistat, air flow switch or a telephone type connection to the electronic control input device.

See figure 5-1 to identify the GTS humidifier control cabinet with its major components.

Figure 5-1: GTS Control Cabinet

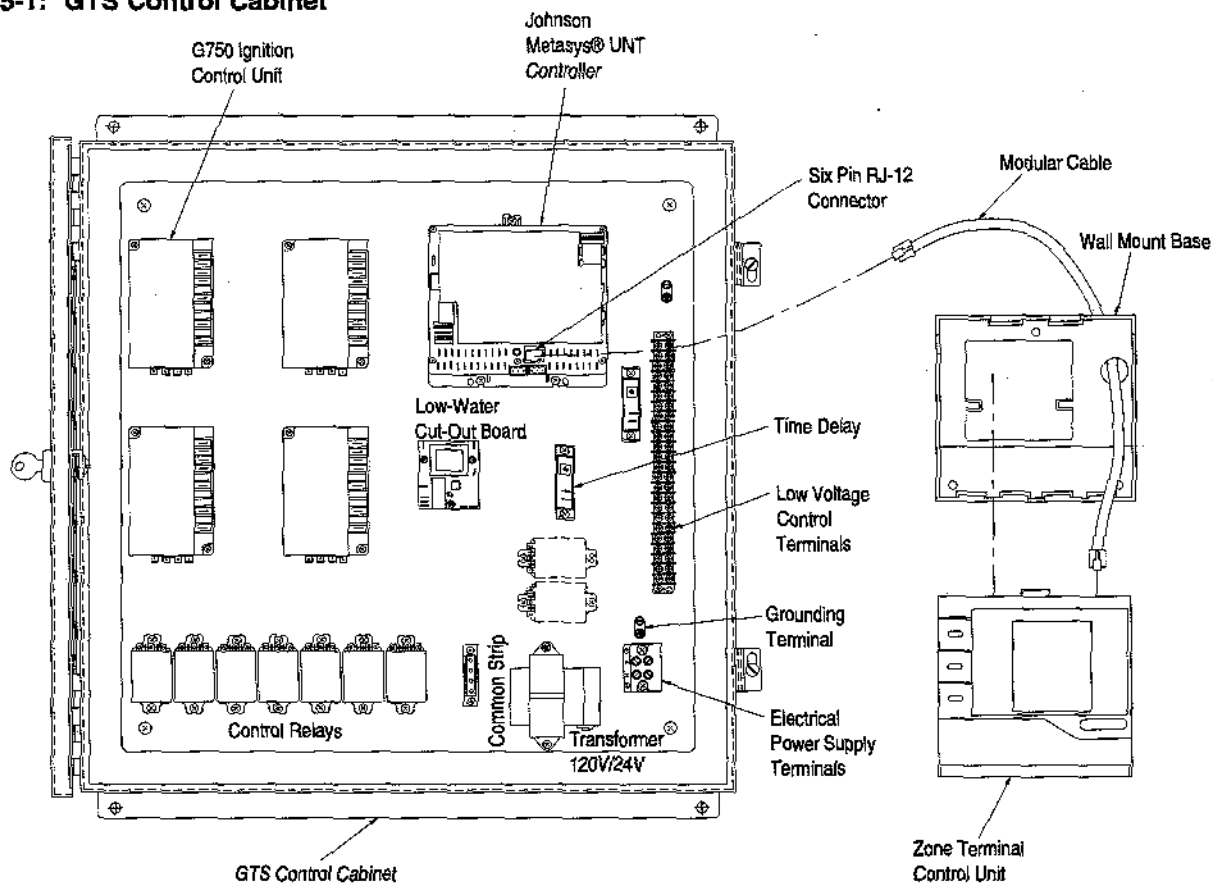

OM-846

# INSTALLATION

Identify the low voltage control terminal block in the GTS™ control cabinet and refer to the control wiring diagram contained within the control cabinet for the identification of each of the terminals.

**Since control requirements vary, ensure the control cabinet wiring diagram that is provided with each unit is used for the actual details of the low voltage control terminal identification and function.**

For the example shown in figure 6-1, the terminals are used as follows.

Terminals 1, 2, and 3 are used for the humidity control.

Terminals 4, 5, and 6 are used for the optional high limit humidity control.

Terminals 7, 8, and 9 are used for the optional temperature compensation sensor.

All of the above controls must be connected using 18 gauge shielded plenum type cable. Only ground control cabinet end of shielded cable.

Terminals 10 and 11 are used for the optional staging control.

Terminals 12 and 13 are used for the air flow proving switch.

Terminals 14, 15, and 16 are used for remote fault indication.

Terminals 17, 18, and 19 are used for the optional power vent package.

Terminals 20 through 23 are used for an optional combustion air damper.

Terminals 20 and 21 are used for the optional area type fan.

## Zone Terminal Control Unit

The Zone Terminal Control Unit is the primary input and monitoring device for the performance of the GTS humidifier. The wall mount base assembly measures 6.94" X 7.44" X 2" and should be mounted in a convenient location **no more than 50 feet wire length** from the GTS humidifier. The modular cable furnished with the equipment should be connected as shown in figure 5-1 with the RJ-12 connector inserted into the socket on the Johnson Mefasys® UNT Controller in the GTS humidifier control cabinet. Refer to control

wiring arrangement in control cabinet for specific connection requirements.

### Installation Notes:

- The interconnect cable furnished is 5 feet in length.
- The Zone Terminal Control Unit may be installed up to 50 feet from the GTS humidifier, however, 18 gauge wire must be used for the connection.
- **Do not** mount the Zone Terminal Control Unit in a vibration area.
- The atmosphere must be free of corrosive chemical vapors which may damage the electronic equipment.

The installation of the Zone Terminal Control Unit must meet the following standards:

1. Ambient operating temperature of 32 to 122°F (0 to 50°C).
2. 10 to 90% non-condensing relative humidity.
3. 86°F (30°C) maximum dew point.

See the next section on page 7 for the programming and operation of the Zone Terminal Control Unit.

**Note: All field wiring to the GTS Humidifier must be suitable for 105°C.**

**All wiring must be installed in accordance with local and National Electrical Codes and ordinances.**

**Always check that the electrical power supply used agrees with the voltage and frequency shown on the equipment nameplate.**

**Figure 6-1: Example of Control Connections**

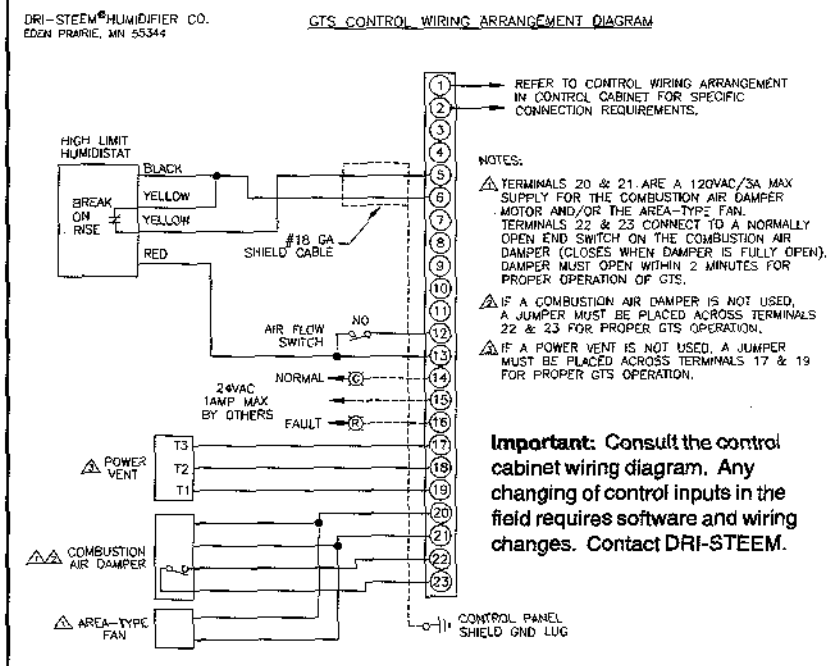

---

# GTS™ OPERATION

---

## Outline of Operation

The GTS is a gas-fired humidifier that burns either natural or propane gas to generate steam for humidification. The unit consists of one or more burners which are fitted into a heat exchanger. This heat exchanger is submerged in a tank of water. When a call for humidity is made the burners fire and boil water to generate steam until the call for humidity ends. The GTS is compatible with all types of DRI-STEEM dispersion devices including RAPID-SORB™ and ULTRA-SORB®.

## Safety Systems

The GTS humidifier has a number of systems and safeguards to ensure proper operation:

- When there is a call for humidity, all of the combustion blowers must start. Each of the combustion blowers contains a centrifugal switch that closes when the motor reaches an operating speed. If any one of the switches fails to close, the GTS will not operate.
- Once the blowers are running, a normally closed pressure switch that senses the back pressure on the blowers will only allow the burners to operate if the flue is unobstructed.
- The water level in the tank is monitored by a probe system for standard water units and a low water float for DI/RO units. These water monitors tie into the microcontroller in the control cabinet. If the water level ever drops below a safe point, the humidifier is shut down.
- The water level in the tank is also monitored by a redundant low water system that is independent of the microcontroller. This system is tied directly into the power source for the burners. If this system detects a low water condition, the humidifier is shut down.
- In addition to monitoring the water level, a temperature sensor located above one of the top burners will shut the humidifier down before an unsafe condition arises.

- For standard water systems, an additional low water safety system exists. The microcontroller keeps track of approximately how much water has left the tank in the form of steam. If this total amount exceeds a preset limit without the fill valve being energized, a low water condition is assumed and the humidifier is shut down. Each time the fill valve is energized, the total is reset to zero. (This system is not implemented on a DI/RO humidifier because the fill valve is not the electric-solenoid type. On a DI/RO tank, a mechanical fill valve maintains the proper water level. This fill valve runs independent of the microcontroller. Therefore, there is no way to reset the steam total to zero as the tank fills.)

## Humidifier Control

The GTS has many different control options available. These options may be grouped into three categories: Transmitter Control, Humidistat Control, and Control By Others. With the Transmitter Control option, the humidity is sensed through a remote transmitter and fed back into the microcontroller. The user then adjusts the setpoint and controls the humidifier using the Zone Terminal Control Unit. In the Humidistat Control option, the humidifier is controlled using a remote humidistat. The humidity setpoint is set on the humidistat. The Zone Terminal is only used for humidifier maintenance, troubleshooting, setting drain/flush cycles, etc. The Control By Others is controlled by a signal from another source such as an energy management system. The Zone Terminal serves the same purpose as it did for the Humidistat Control option. These control options are described in more detail in the following paragraphs.

## Transmitter Control

The GTS humidifier is controlled by a Johnson Controls UNT Controller with a Zone Terminal interface. The basic control algorithm is a PI loop (Proportional-Integral). This control loop takes the signal from the humidity sensor and compares it with the setpoint determined by the user. From these pieces of information, the loop generates a demand signal which the humidifier then carries out. This process of comparing the signal with the setpoint and updating the demand is repeated every 1.5 seconds.

---

## MULTIPLE-TANK GTS™ OPERATION

---

### Outline of Operation

The multiple tank GTS systems work in much the same way that the single tank systems do. A multiple tank system consists of 2 to 6 "slave" GTS systems. These systems are complete stand-alone GTS humidifiers with their own control cabinet. They are tied together through a Johnson Controls AHU controller. This controller accepts input from the various RH sensors. It then generates demand signals which it passes on to each one of the slave GTS systems. The slave GTS systems simply do what they are told.

Each of the slaves control their water level and safety systems individually. If there is a problem, they open a set of contacts that the AHU controller is monitoring. The AHU then puts an alarm on the ZTU. If an individual slave GTS enters a fault condition, the remainder of the system will continue to run. The AHU controller will transfer the demand signal from the slave that has the fault to one of the remaining slaves that is running normally (if one is available).

### Connections

The connections between the AHU controller and the RH sensors are exactly the same as they would be on an

individual tank system. There are two connections between the AHU controller and each one of the slave systems. The first is a 4-20mA demand signal. The AHU generates this signal for each of the slaves. The slaves respond to it by producing output. The second signal is a feedback signal from the slaves to the AHU controller. This is just an open/closed contact signal. If the slave is running normally, the contacts will be closed. If the slave enters a fault condition, it will open the contacts to inform the AHU controller.

If a slave does enter a fault condition, the ZTU can be used to determine what the fault is. To read the fault, first unplug the ZTU from the AHU controller. Then, replace the plastic overlay in the ZTU with the overlay for the slaves. Next, connect the ZTU to the slave with the fault. (Note - all of these connections to the ZTU can be made with the power to the GTS and AHU on.) Now, by toggling down to the "Error Code" position on the ZTU, you should be able to read the fault code. When you have corrected the fault, simply replace the overlay on the ZTU with the main one for the AHU and re-connect the ZTU to the AHU controller.



# PROGRAMMING OF THE ZONE TERMINAL CONTROL UNIT

## PI Loop Control

The PI loop has five control parameters that the user can adjust. They are the setpoint (Set % RH), the proportional band (Set Prop Band), the integral or reset (Set Integral), the deadband (Set Deadband) and the offset (Set RH Offset). (The information in parenthesis is how these variables actually appear on the Zone Terminal display.) A review of each parameter individually is as follows:

**Setpoint** - The setpoint is the ultimate humidity level that the user would like to achieve.

**Proportional Band** - This is the band (in % RH) in which the humidifier will modulate. For example, if starting with a setpoint of 35% and a proportional band of -10% the humidifier operation will be as follows: On initial startup, assume an actual humidity level of 15%. The proportional band is -10% so the humidifier will modulate when the actual humidity is in the range 25-35%. If the actual humidity is lower than 25%, the humidifier will be full on. If the actual humidity is above 35%, the humidifier will be full off. In the example, starting at an actual humidity level of 15%, the humidifier will be full on. As the actual humidity level climbs into the range of the proportional band (25-35%), the humidifier will begin to modulate down. Once the setpoint of 35% is reached, the humidifier will be full off. Looking at this scheme a little closer, a problem can be found. In almost all applications, there will be some constant load on the humidifier just as there is a constant load on the heating equipment. With this control scheme, the actual humidity must be less than the setpoint for the humidifier to be on. What ends up happening is the humidifier finds a "happy medium" where the actual humidity is something less than the setpoint which allows the humidifier to continue to run. This difference between the setpoint and the actual running humidity level is called the "droop". This droop can be corrected using the next term, the integral.

**Integral or Reset** - This is a variable which determines how fast the humidifier will react to a droop condition. The lower the number, the faster the reaction. (An integral term of zero disables this variable and allows the unit to run on the proportional band only.) The way this term works is as follows: When the actual humidity is in the proportional band, the humidifier demand is somewhere between 0 and 100 percent. Every 1.5 seconds

the demand is updated. With an integral term greater than zero, each time the demand is updated it is increased slightly. The amount it is increased is dependent on the integral term and the difference between the actual humidity and the setpoint. (The closer you are to the setpoint, the smaller the addition. The larger the integral term, the smaller the addition.) When looking at this control scheme, something interesting is found. The total demand signal for the humidifier is the sum of the proportional part and the integral part. As the actual humidity approaches the setpoint, the integral portion makes up the majority of the demand and the proportional part makes up very little. Once the setpoint is achieved, the entire demand is made up of the integral part because the proportional part is zero.

**Deadband** - The deadband is the band around the setpoint in which the demand signal is frozen. In other words, if we have a setpoint of 35% and a deadband of 1%, the demand signal will remain unchanged for an actual humidity between 34% and 36%. (If the system demand was at 43% when the actual humidity entered this range, it will be locked at 43% as long as the actual humidity is in this range.)

**Offset** - The offset allows the user to calibrate the humidity sensor to any source. If the display indicates that the actual humidity is 35% and your humidity sensor says 37%, a correction can be made by entering an offset of +2% to compensate for the difference.

**Setup Tips** - A large proportional band (-10 to -20%) will yield tighter and more stable control with longer response time. A small proportional band will produce quicker response times but control may become unstable. As a rule of thumb, start with a band of -10%. If the unit does not "hunt" and quicker response is needed, the band can be lowered. If the unit hunts or the fast response is not needed, increase the band. This will give more system stability. A large integral term (75 to 150) will also yield tighter and more stable control with a longer response time. A small integral will quicken the response but may cause the control to become unstable. As a rule of thumb, start with an integral term of 100. If the unit does not "hunt" and quicker response is needed, lower the integral. If the unit hunts or does not need the fast response, increase the integral. In most applications, the

## PROGRAMMING OF THE ZONE TERMINAL CONTROL UNIT

deadband is set to zero. If you are controlling a zone which can have abrupt changes in humidity (a shipping dock with opening and closing garage doors), increase the deadband to 1 or 2 percent. This will allow the humidifier to run through these changes instead of hunting.

**Optional Features** - With transmitter control, several options are available including Cold Snap Offset and VAV. With the Cold Snap Offset option, a window temperature sensor is provided. This sensor monitors the window temperature and automatically lowers the humidity to prevent window condensation in the event of extremely cold weather. With the VAV option, a duct humidity transmitter is provided. This transmitter monitors the duct condition and automatically lowers the system demand when the duct humidity approaches a high limit point that is entered into the Zone Terminal by the user. The difference between this system and a standard high limit system is in the modulation. The VAV system will modulate the output and maintain a duct condition as close to the high limit as possible until the room condition is satisfied. A standard high limit system will shut down the humidifier completely when the duct hits the high limit setpoint.

### **Humidistat Control**

In this scenario, the humidifier is controlled by a remote humidistat that provides a demand signal back to the UNT Controller. The humidifier then runs until the demand signal is satisfied. The humidity setpoint is adjusted on the humidistat rather than on the Zone Terminal.

### **Control By Others**

In this scenario, the humidifier is controlled by a remote source that sends a demand signal back to the UNT Controller. The humidifier then runs until the demand signal is satisfied. The signal source is typically an energy management system or some other form of building automation system.

### **Humidifier Operation**

The GTS has one or more burners which are capable of being modulated on and off for short times (as low as 6 seconds). As the demand signal changes, burners are staged on and off to meet the demand. To achieve better control, one burner is the modulating burner. The remaining burners are staged on or off to approach the demand. The modulating burner is then "pulsed" on and off over a 2 minute time base. In other words, the burner is on for anywhere from 6 seconds to the full 2 minutes and then the cycle repeats. After the modulating burner reaches 5000 cycles, another burner will become the modulating burner. This provides for even wear on all of the burners and gas valves, thus extending humidifier life. (This system is similar to the existing DRI-STEEM Time Proportioning system found on the electric VAPORSTREAM® humidifiers.)

**Optional Feature** - When there has been no call for humidity for 72 continuous hours, the unit will go into an "end of season drain" cycle. The tank will drain and the unit will shut down. Upon a call for humidity, the unit will refill and resume normal operation.

### **Zone Terminal Control Unit**

The following description of operation and features is reviewed as an example of the capability of the Zone Terminal Control Unit. Not all features and/or operation may have been selected for a specific job.

A picture of the Zone Terminal Control Unit is shown in figure 11-1 with the bottom flap open. This is the interface device that allows the user to monitor and control the humidifier. A description of the keys, parameters and status points is as follows.

# PROGRAMMING OF THE ZONE TERMINAL CONTROL UNIT

Figure 11-1: Example for Zone Terminal Control Unit Display

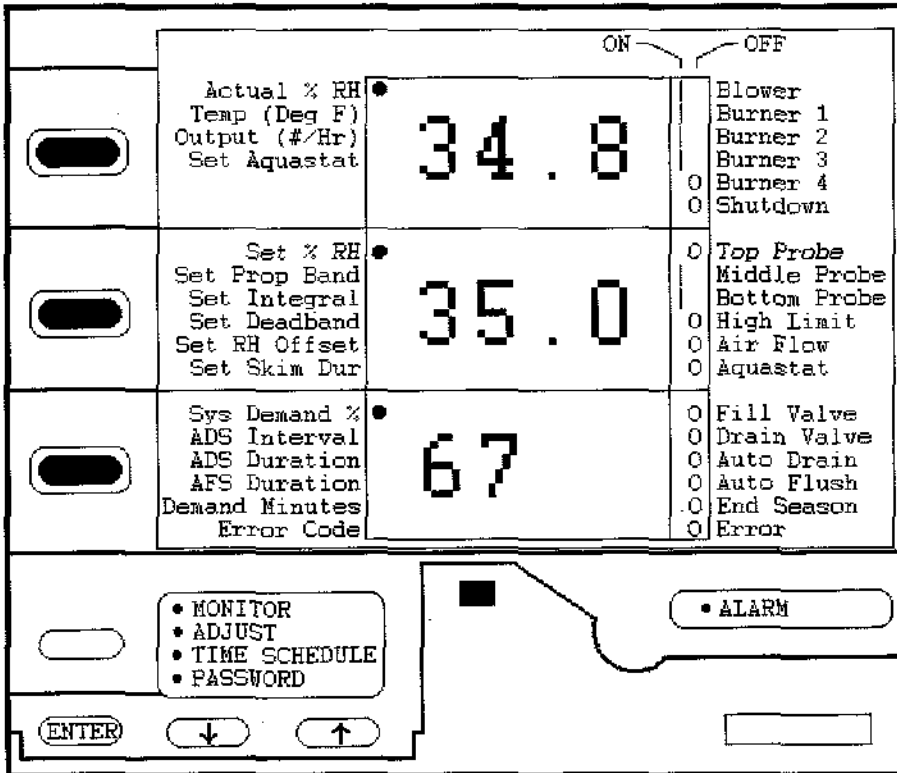

## Keys

The three keys on the left toggle through the parameters listed on the left side of the display. For example, the top key would toggle through Actual % RH, Temp (Deg F), Output (#/Hr), and Set Aquastat. The other two keys would toggle through the parameters to the right of them. The parameter being shown will have a black dot to the right of its name. In the figure 11-1, the parameters "Actual % RH", "Set % RH" and "Sys Demand %" are being displayed.

The key to the left of the section containing MONITOR, ADJUST, TIME SCHEDULE and PASSWORD toggles the operating mode of the keypad. When in the MONITOR mode, the user is only able to view the information on the display. When the key is pressed once, the ADJUST mode is entered. When in this mode, the user is able to change certain parameters on the display. Pressing the key again will enter the PASSWORD mode which is not used. Pressing the key again will reenter the MONITOR mode. (Time schedule is not used on the GTSTM.)

The three keys on the bottom are for adjusting parameters. To adjust a parameter, press the key discussed above until you are in the ADJUST mode. Then, press one of the 3 keys on the left of the display until the parameter that you would like to modify is selected. If the parameter that you have selected is adjustable it will

be flashing. If it is not flashing, the parameter that you have selected is a status parameter and is not eligible for adjustment. With the parameter flashing, press the up or down arrow key until the desired value is reached. Press the ENTER key to lock in the new value. The user can now modify other parameters as may be desired. Once the modifications are completed, the operating mode key discussed above must be returned to the MONITOR mode.

**Note:** When adjustments are made, the ENTER key must be pressed in order for them to be remembered and entered into the program. If the ENTER key is not pressed, the data will be lost when returning to the MONITOR mode.

## Parameters

Following this is a list of parameters that may appear on the Zone Terminal Control Unit. Not all of these items may be present depending on the options selected on the humidifier:

**Actual % RH** - This is a read only parameter which displays the actual humidity being sensed by the humidity sensor.

**Actual HL % RH** - This is a read only parameter which displays the actual duct humidity being sensed by the duct humidity sensor. This is used with the VAV option.

## PROGRAMMING OF THE ZONE TERMINAL CONTROL UNIT

- Glass Temp** - This is a read only parameter which displays the actual glass temperature being sensed by the window sensor. This is used with the Cold Snap Offset option.
- Temp (Deg F)** - This is a read only parameter which displays the temperature (in degrees Fahrenheit) of the sensor located above one of the top burners.
- Output (#/Hr)** - This is a read only parameter which displays the actual steam output of the humidifier in pounds per hour.
- Set Aquastat** - This is a changeable parameter which allows the user to set the aquastat setpoint of the humidifier. This setpoint allows the user to maintain a minimum tank temperature. If the tank temperature drops below the setpoint, a burner will fire until the tank is again warmer than the setpoint. This function can be used to keep the tank from freezing in a cold room application by setting a minimum temperature of 40° F. It can also be used to keep the tank "hot" in a critical control application by setting a minimum temperature of approximately 150° F. In this application, when a call for humidity is received, the humidifier will be able to produce steam almost instantaneously because it will already be hot.
- Set % RH** - This is a changeable parameter which allows the user to set the actual humidity setpoint that the humidifier will maintain.
- Set HL % RH** - This is a changeable parameter which allows the user to set the actual high limit humidity setpoint that the humidifier will maintain in a high humidity duct condition. This is used with the VAV option.
- Set Prop Band** - This is a changeable parameter which allows the user to adjust the proportional % RH band through which the humidifier will modulate.
- Set Integral** - This is a changeable parameter which allows the user to adjust the integral term which will correct for the droop as the actual humidity enters the proportional band.
- Set Deadband** - This is a changeable parameter which allows the user to adjust the band around the setpoint for which the demand will be frozen.
- Set RH Offset** - This is a changeable parameter which allows the user to calibrate or sync the humidifier sensor with a sensor provided by the user.
- Set HL Offset** - This is a changeable parameter which allows the user to calibrate or sync the humidifier high limit sensor with a sensor provided by the user. This is used with the VAV option.
- Set Temp Offst** - This is a changeable parameter which allows the user to calibrate or sync the humidifier window temperature sensor with a temperature sensor provided by the user. This is used with the Cold Snap Offset option.
- Set Skim Duration** - This is a changeable parameter which allows the user to set the amount of skim for the humidifier. This parameter is in seconds. The skim operates as follows: At the end of a fill cycle, the fill valve remains energized for an additional time equal to the skim duration. This causes the tank to overflow slightly which skims the surface of the water and sends the surface minerals down the overflow. For hard water, a larger skim time may be desired (10-20 seconds). For softened water, a minimum skim time is needed (3 seconds).
- Sys Demand %** - This is a read only parameter which displays the system demand on the humidifier as a percentage.
- ADS Interval** - This is a changeable parameter which allows the user to set the time interval for the drain and flush cycle. This parameter is in hours. The automatic drain and flush sequence works as follows: After the humidifier has run (actually produced steam) for the time set in the ADS Interval, the unit enters a drain and flush cycle. The drain valve opens for the time specified in the ADS Duration and then the drain and fill valves open for the time specified in the AFS Duration. Upon completion, the unit returns to normal operation. For hard water, a smaller interval may be desired (30-50 hours). For softened water, a larger interval is desirable (99 hours).
- ADS Duration** - This is a changeable parameter which allows the user to set the time that the drain valve will open in a drain and flush cycle (see above). This parameter is in minutes. For hard water, a longer duration may be desired (8-15 minutes). For softened water, a smaller duration is desirable (1-2 minutes).
- AFS Duration** - This is a changeable parameter which allows the user to set the time that the drain and fill valves are open in a drain and flush cycle (see above). This parameter is in minutes. For hard water, a longer duration may be desired (8-15 minutes). For softened water, a smaller duration is desirable (1-2 minutes).

---

## PROGRAMMING OF THE ZONE TERMINAL CONTROL UNIT

---

**Pnds Converted** - This is a read only parameter which displays the number of pounds of water converted to steam since the last fill cycle. It is part of the low water safety system.

**Hours To EOS** - This is a read only parameter which displays the number of hours remaining before the unit enters the end of season drain cycle.

**Hours To ADS** - This is a read only parameter which displays the number of hours remaining before the unit enters the next drain and flush cycle.

**Service Time** - This is a read only parameter which displays the number of hours remaining before the next recommended servicing.

**Tank 1 Command** - This is a read only parameter which displays the demand % on the number 1 slave GTS™ in a multiple-tank system.

**Tank 2 Command** - This is a read only parameter which displays the demand % on the number 2 slave GTS in a multiple-tank system.

**Tank 3 Command** - This is a read only parameter which displays the demand % on the number 3 slave GTS in a multiple-tank system.

**Tank 4 Command** - This is a read only parameter which displays the demand % on the number 4 slave GTS in a multiple-tank system.

**Tank 5 Command** - This is a read only parameter which displays the demand % on the number 5 slave GTS in a multiple-tank system.

**Tank 6 Command** - This is a read only parameter which displays the demand % on the number 6 slave GTS in a multiple-tank system.

### Error Codes

The error code is visible on the bottom line of the keypad display. They are explained in more detail in the next section covering the Johnson Metasys® UNT Controller. The error codes are listed here for information.

**Note:** Not all error codes may be functional if that particular item or feature was not ordered for the particular GTS humidifier.

**Error Code** - This is a read only parameter which displays an error code in the event a humidifier error occurs.

A listing of the error codes follows:

0 -> Normal Operation

1 -> Sensor Fault - The humidity sensor is incorrectly wired or bad

2 -> Water Level Fault - The probes are incorrectly wired or an illegal water level exists

3 -> Fill Valve Fault - The fill valve has been energized for more than 40 minutes

4 -> Drain Valve Fault - The drain valve has been energized for more than 30 minutes

5 -> Low Water Timer Fault - The unit has run too long without the fill valve opening

6 -> Blocked Flue Fault - The pressure in the flue is too high

7 -> Over Temp Fault - The unit has exceeded the maximum safe operating temperature

8 -> Humidistat Fault - The humidistat is incorrectly wired or bad

9 -> Window Sensor Fault - The window temperature sensor is incorrectly wired or bad

10 -> High Limit Sensor Fault - The high limit humidity sensor is incorrectly wired or bad

11 -> Slave Fault - The slave board is incorrectly wired to the master control panel or is receiving a bad signal

12 -> Temperature Sensor Fault - The temperature sensor on the humidifier tank is incorrectly wired or bad

13 -> Slave 1 Fault - Slave GTS #1 has a fault condition

14 -> Slave 2 Fault - Slave GTS #2 has a fault condition

15 -> Slave 3 Fault - Slave GTS #3 has a fault condition

16 -> Slave 4 Fault - Slave GTS #4 has a fault condition

17 -> Slave 5 Fault - Slave GTS #5 has a fault condition

18 -> Slave 6 Fault - Slave GTS #6 has a fault condition

## PROGRAMMING OF THE ZONE TERMINAL CONTROL UNIT

### Status Points:

The status point indicator and description are to the right of the display area on the Zone Terminal Control Unit. See figure 11-1. The vertical bar or "I" indicates an "ON" state. The "O" indicates an "OFF" state. The exact description for each is listed below.

<u>Point</u>	<u>I</u>	<u>O</u>
Blower	The burner blowers are on	The burner blowers are off
Burner 1	Burner #1 is on	Burner #1 is off
Burner 2	Burner #2 is on	Burner #2 is off
Burner 3	Burner #3 is on	Burner #3 is off
Burner 4	Burner #4 is on	Burner #4 is off
Shutdown	The unit is in shutdown	The unit is ready to run
Top Probe	There is water on the top probe	There is no water on the top probe
Middle Probe	There is water on the middle probe	There is no water on the middle probe
Bottom Probe	There is water on the bottom probe	There is no water on the bottom probe
High Limit	The humidity high limit has been reached	The humidity high limit is OK
Air Flow	There is air flow for humidification	There is no air flow
Aquastat	The tank temperature is below the set aquastat temperature	The tank temperature is above the set aquastat temperature
Fill Valve	The fill valve is on	The fill valve is off
Drain Valve	The drain valve is on	The drain valve is off
Auto Drain	The auto drain sequence is in progress	The auto drain sequence is off
Auto Flush	The auto flush sequence is in progress	The auto flush sequence is off
End Season Drain	The unit is in the end of season drain mode	The end of season drain is off
Glass Status	The glass is too cold for the unit to run	The glass temperature is OK
VAV Limit	The output of the unit is being limited to keep the duct from saturating	The output of the unit is unrestricted
Service	The recommended time between services has expired	No maintenance is required
Low Water Error	The unit is in a low water condition An error has occurred, check the error code	There is water in the unit The unit is operating normally
GTS™ 1 Status	GTS #1 is in a fault condition	GTS #1 is running normally
GTS 2 Status	GTS #2 is in a fault condition	GTS #2 is running normally
GTS 3 Status	GTS #3 is in a fault condition	GTS #3 is running normally
GTS 4 Status	GTS #4 is in a fault condition	GTS #4 is running normally
GTS 5 Status	GTS #5 is in a fault condition	GTS #5 is running normally
GTS 6 Status	GTS #6 is in a fault condition	GTS #6 is running normally

**Note:** Not all status points may be functional if that particular item or feature is not present on the GTS humidifier.

# OPERATION OF THE JOHNSON METASYS® UNT CONTROLLER

## Water Level Control\*

The water level in the evaporating chamber is controlled by a three-probe sensor mounted through the top of the chamber. See figure 15-1.

UNT cycles valve to maintain the proper level. When the power is turned on, the valve opens and begins filling the evaporating chamber. When the water reaches level "A," the fill valve closes. A call for humidity will then energize the GTS™ humidifier and the humidification process begins.

During operation the water level eventually drops to level "B." At this time the fill valve opens. The fill valve will remain open until the water level returns to "A." The burners will remain energized to provide a consistent output.

If in the event of water supply failure, the water line falls below level "C," the burners will be de-energized. The heat will remain off until the water level is restored to level "C." This action provides protection in the event of a low-water condition.

Due to the boiling that may occur inside the humidifier, a delay is placed in the software on the probe system. For any state to exist (water on the probe or no water on the probe) the condition must remain constant for 3 seconds. This keeps the fill valve from rapid-cycling.

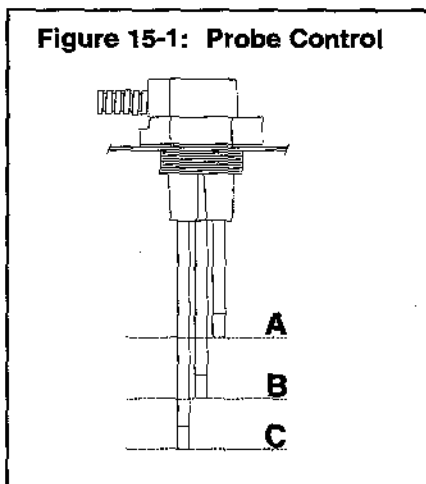

## Drain and Flush Cycle\*

The Drain and Flush cycle will initiate after the humidifier has been making steam for the time stored in the ADS Interval. Once the cycle has begun, the humidifier will shut down and go into a drain cycle for the time stored in ADS Duration. After the drain cycle has expired, the unit will go into a flush cycle (drain and fill valves open) for the time stored in AFS Duration. Once the flush cycle has expired, the unit will refill with water and return to normal operation. During the drain and flush sequences, the appropriate displays on the ZTU shall be moved into the "On" position. This situation will NOT cause the Alarm light on the ZTU to activate. Note - By setting the ADS Interval to 0, the drain and flush cycle can be eliminated.

## Skim Time\*

The Skim Time feature controls the amount of water skimmed at each fill cycle. As the unit is filling and water starts to reach the top probe, the fill valve will stay on until the water has been in contact with the top probe for the time specified in the Skim Time. This will cause the unit to overfill and the top layer of water will be skimmed off through the overflow. Note - The Skim Time has a minimum setting of 3 seconds.

## End Of Season Drain

The End of Season Drain is a function that is activated when there has been no call for humidity in the last 72 hours. This function will disable the fill valve and open the drain valve to drain the tank. The ZTU will then activate the End Season Drain display ("On" position). The unit will then go into a wait state. If a call for humidity comes, the UNT will fill the tank with water and the humidifier will begin to make steam. The End Season Drain indicator will be reset to the "Off" position.

\*Note: This feature is not applicable to DI/RO models.

# OPERATION OF THE JOHNSON METASYS® UNT CONTROLLER

## Faults and Alarms

The UNT control will monitor the system for the following faults and issue an error code that is visible on the bottom line of the zone terminal control unit key pad display.

**Normal State (#0)** - The humidifier is operating normally.

**Humidity Transmitter Fault (#1)** - If the humidity transmitter signal ever falls out of the 1-5 VDC range, the UNT will shut down the humidifier and display Error Code 1. The ZTU will move the Error binary display to the "On" position.

**Water Level Fault (#2)** - If the probe system ever detects an illegal state, the UNT will shut down the humidifier and display Error Code 2. The ZTU will move the Error binary display to the "On" position. An illegal state is any one of the following:

Top Probe	No Water	Water	Water	Water
Middle Probe	Water	Water	No Water	No Water
Bottom Probe	No Water	No Water	No Water	Water

**Fill Fault (#3)** - If the fill valve is ever open for more than 60 minutes, the UNT will shut down the humidifier and display Error Code 3. The ZTU will move the Error binary display to the "On" position.

**Drain Fault (#4)** - If the drain valve is ever open for more than 30 minutes and the water level does not drop off the bottom probe, the UNT will shut down the humidifier and display Error Code 4. The ZTU will move the Error binary display to the "On" position.

**Low-Water Timer Fault (#5)** - The humidifier keeps track of approximately how much steam has been produced as it is running. If this amount of steam exceeds a certain predetermined amount without the fill valve coming on, the UNT will shut down the humidifier and display Error Code 5. The ZTU will move the Error binary display to the "On" position.

**Blocked Flue Fault (#6)** - The humidifier shall measure the pressure in the flue. If the pressure is too high, the UNT will shut down the humidifier and display Error Code 6. The ZTU will move the Error binary display to the "On" position.

**Over Temp Fault (#7)** - The humidifier shall measure the operating temperature of the tank. If the temperature exceeds 235° F, the UNT will shut down the humidifier

and display Error Code 7. The ZTU will move the Error binary display to the "On" position.

**Humidistat Fault (#8)** - If the signal from the humidistat ever falls outside of its normal range, the UNT will shut down the humidifier and display Error Code 8. The ZTU will move the Error binary display to the "On" position.

**Window Sensor Fault (#9)** - If the temperature transmitter signal ever falls out of the 1-5VDC range, the UNT will shut down the humidifier and display Error Code 9. The ZTU will move the Error binary display to the "On" position.

**High Limit Sensor Fault (#10)** - If high limit, or duct, humidity transmitter signal ever falls out of the 1-5VDC range, the UNT will shut down the humidifier and display Error Code 10. The ZTU will move the Error binary display to the "On" position.

**Slave Fault (#11)** - If the signal coming from the master control board ever falls outside of the 0-10VDC range, the UNT will shut down the humidifier and display Error Code 11. The ZTU will move the Error binary display to the "On" position.

**Temperature Sensor Fault (#12)** - If the signal from the tank temperature sensor ever falls outside of its normal range, the UNT will shut down the humidifier and display Error Code 12. The ZTU will move the Error binary display to the "On" position.

**Slave 1 Fault (#13)** - The Slave #1 GTS™ has experienced some type of fault. (This fault is only applicable to multiple tank GTS systems.)

**Slave 2 Fault (#14)** - The Slave #2 GTS has experienced some type of fault. (This fault is only applicable to multiple tank GTS systems.)

**Slave 3 Fault (#15)** - The Slave #3 GTS has experienced some type of fault. (This fault is only applicable to multiple tank GTS systems.)

**Slave 4 Fault (#16)** - The Slave #4 GTS has experienced some type of fault. (This fault is only applicable to multiple tank GTS systems.)

**Slave 5 Fault (#17)** - The Slave #5 GTS has experienced some type of fault. (This fault is only applicable to multiple tank GTS systems.)

**Slave 6 Fault (#18)** - The Slave #6 GTS has experienced some type of fault. (This fault is only applicable to multiple tank GTS systems.)



# START-UP AND OPERATION

## Start-up

Before a start-up of the GTST<sup>™</sup> humidifier, it is mandatory that the Start-up and Operation section of the GTS User's/Installation Instructions and Maintenance Operations Manual be reviewed. The review must include all the items listed for the Startup and Checkout Procedures covering the gas and water piping, as well as, the electrical power and control wiring. This manual was provided with the humidifier.

When the checkout has been satisfactorily completed, turn on the main electrical power supply to the humidifier and create a demand for humidity by increasing the RH setting at the Zone Terminal Control Unit.

The blowers within the humidifier will be energized and the centrifugal blower switches will make and power up the ignition controls. After the burner gas ignites within the trial time for ignition, the hot surface ignitor will be powered down. The flame sensor will signal the gas

control valve to remain open while there is a call for humidity. With a single trial ignition controller the control will lockout if a flame is not sensed within the trial time for ignition. On multi (three) trial models, trial for ignition will be repeated for a total of three trials after an interpurge period of thirty seconds. Control will lockout if main burner flame is not sensed at the end of the third trial.

To reset the gas control valve, the demand for humidity must be turned off for a minimum of 30 seconds. If the burner flame goes out (flame loss during a call for humidity), the control will restart the sequence.

## WARNING

Fire or explosion hazard. Avoid personal injury or property damage by making sure the control functions properly and there are no gas leaks. Follow this check-out and start-up procedure before leaving the installation.

Figure 17-1: GTS Humidifier Ignition Sequence

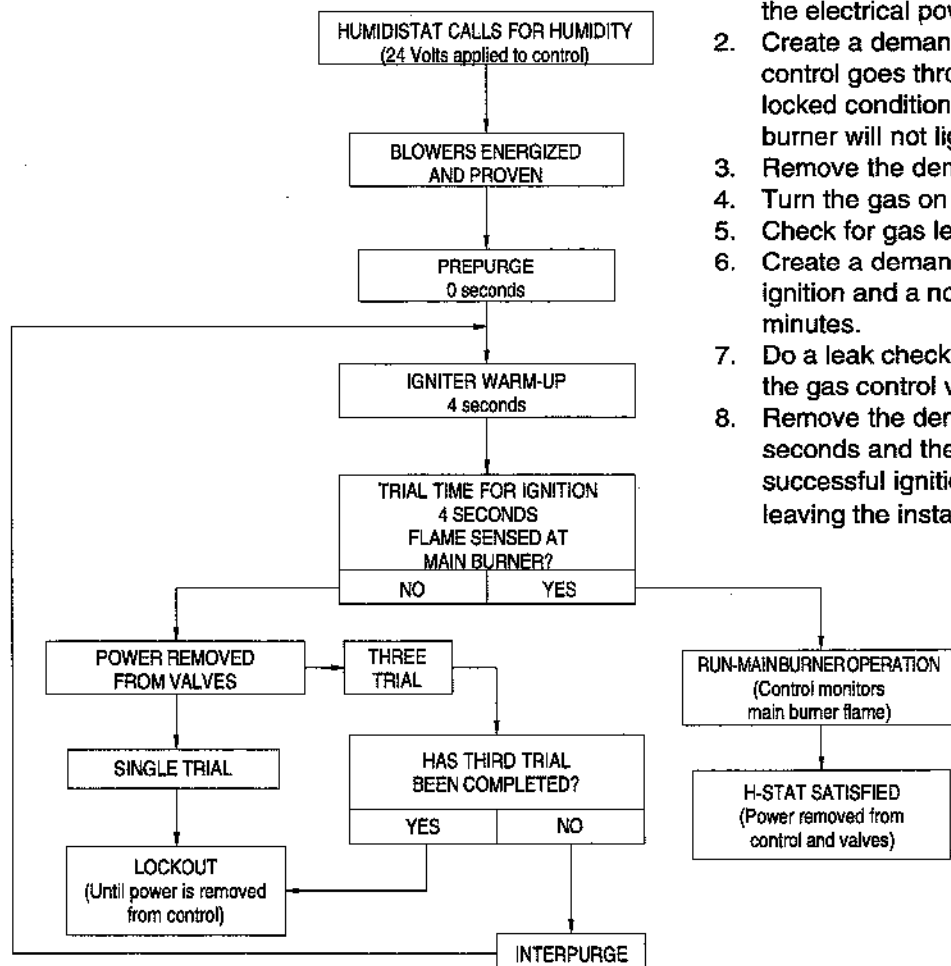

Perform the following lockout test to make sure the control is functioning properly.

1. With the gas off and no demand for humidity, turn on the electrical power to the humidifier.
2. Create a demand for humidity and verify that the control goes through the operating sequence to a locked condition. See figure 17-1. **Note:** The burner will not light because the gas is off.
3. Remove the demand for humidity.
4. Turn the gas on and purge the gas lines of all air.
5. Check for gas leaks with a leak detector.
6. Create a demand for humidity and verify successful ignition and a normal run condition for at least three minutes.
7. Do a leak check on all the pipe joints downstream of the gas control valves.
8. Remove the demand for humidity for at least 30 seconds and then create the demand again. Verify successful ignition at least three times before leaving the installation.

# SAMPLE GTS™ WIRING DIAGRAM

## GTS WIRING SCHEMATIC

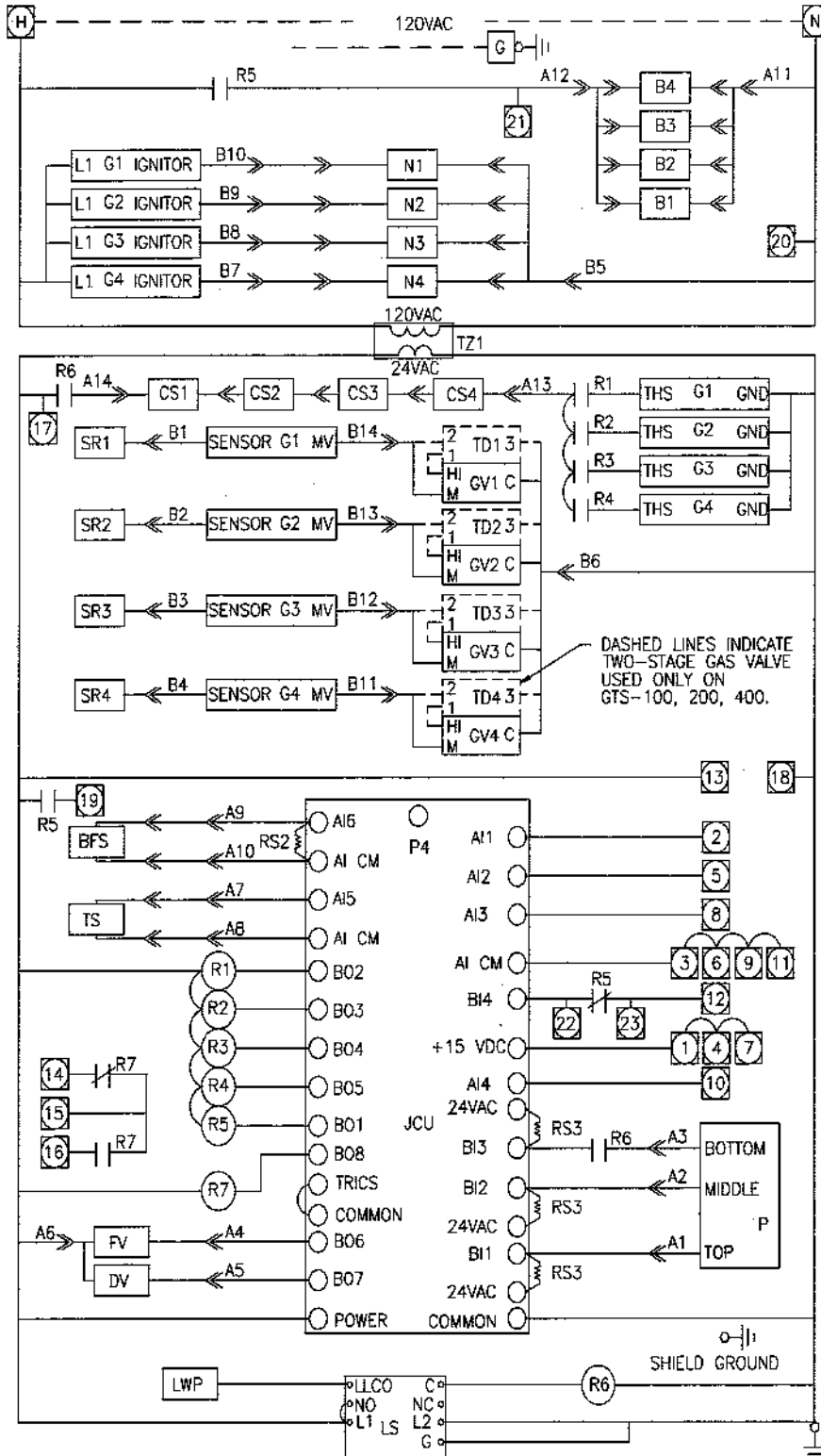

### LEGEND

SYMBOL	DESCRIPTION
B1/4	BLOWER
BFS	SENSOR-BLOCKED FLUE
CS1/4	SWITCH-CENTRIFUGAL
DV	VALVE-DRAIN
FV	VALVE-FILL
G1/4	CONTROLLER-G750
GV1/4	VALVE-GAS
JCU	CONTROLLER-JOHNSON
N1/4	IGNITOR
LS	CONTROL-LWCS2683A0
LWP	PROBE-LOW WATER
P	PROBES
R1/4	RELAY-CONTROL
R5	RELAY-BLOWER
R6	RELAY-SAFETY
R7	RELAY-REMOTE FAULT
RS2	RESISTOR-1K ohm
RS3	RESISTOR-16.5K ohm
SR1/4	SENSOR-ROD
TZ1	TRANSFORMER CLASS 2

DASHED LINES INDICATE TWO-STAGE GAS VALVE USED ONLY ON GTS-100, 200, 400.

### PLUG A & B FEMALE (WIRE SIDE)

5	4	3	2	1
10	9	8	7	6
	14	13	12	11

### PLUG A & B MALE (WIRE SIDE)

1	2	3	4	5
6	7	8	9	10
11	12	13	14	

- FIELD WIRING
- - - - - OPTIONAL WIRING
- \_\_\_\_\_ FACTORY WIRING

# SAMPLE GTS™ WIRING DIAGRAM

## GTS™-DI WIRING SCHEMATIC

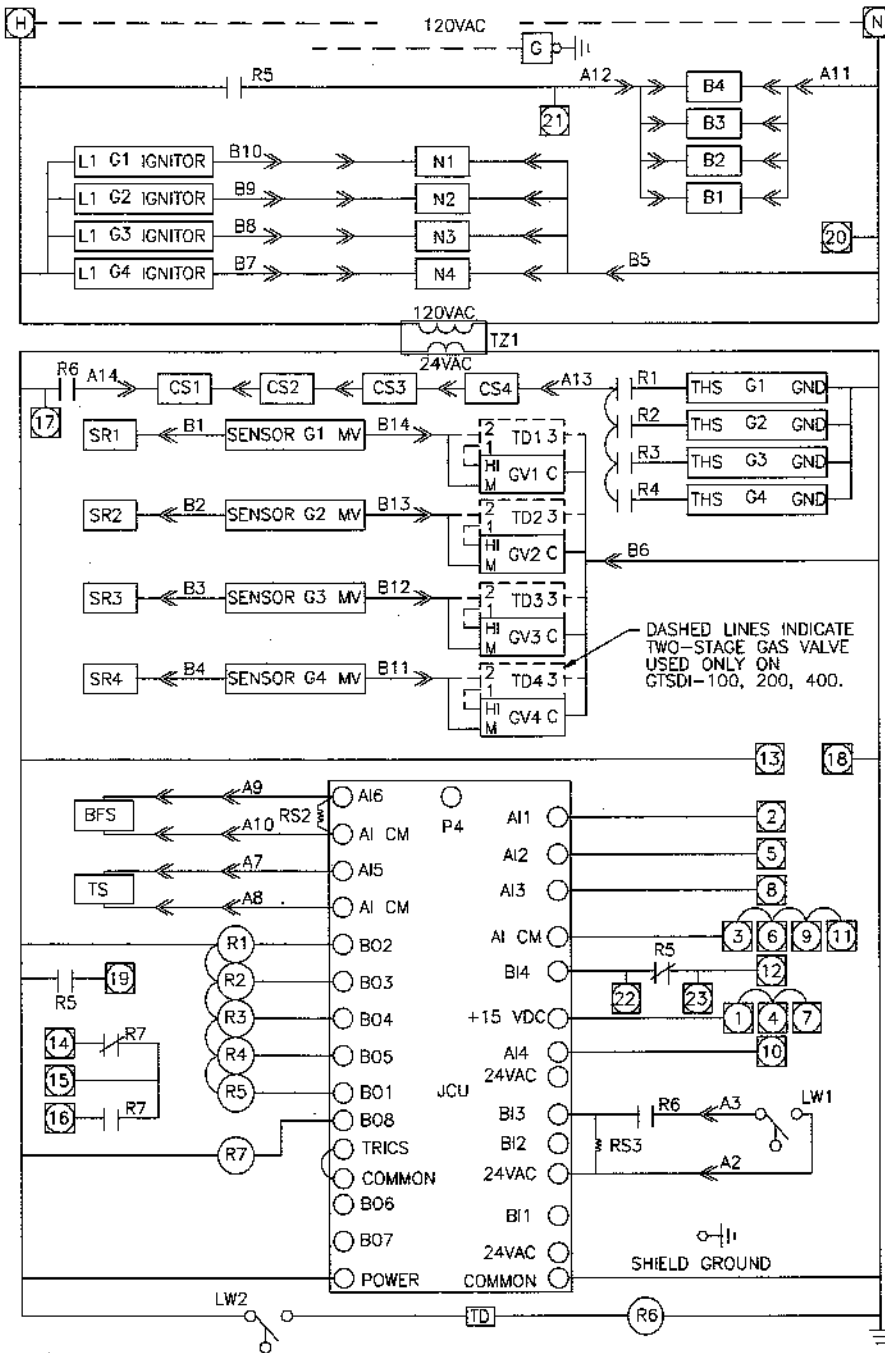

### LEGEND

SYMBOL	DESCRIPTION
B1/4	BLOWER
BFS	SENSOR-BLOCKED FLUE
CS1/4	SWITCH-CENTRIFUGAL
G1/4	CONTROLLER-G750
GV1/4	VALVE-GAS
JCU	CONTROLLER-JOHNSON
N1/4	IGNITOR
LW1/2	SWITCH-LOW WATER
R1/4	RELAY-CONTROL
R5	RELAY-BLOWER
R6	RELAY-SAFETY
R7	RELAY-REMOTE FAULT
RS3	RESISTOR-16.5K ohm
RS2	RESISTOR-1K ohm
SR1/4	SENSOR-ROD
TZ1	TRANSFORMER CLASS 2
TD	TIME DELAY

### PLUG A & B FEMALE (WIRE SIDE)

5	4	3	2	1
10	9	8	7	6
14	13	12	11	

### PLUG A & B MALE (WIRE SIDE)

1	2	3	4	5
6	7	8	9	10
11	12	13	14	

- FIELD WIRING
- OPTIONAL WIRING
- FACTORY WIRING

# SAMPLE GTS™ WIRING DIAGRAM

## GTS™ WIRE DIAGRAM 4 BURNER/AUTO DRAIN/AREA-TYPE/POWER VENT/AIR DAMPER

RS2=1k ohm RESISTOR  
RS3=16.5K ohm RESISTOR

- ⚠ 20 & 21 = 120 VAC/3A MAX TO COMBUSTION AIR DAMPER MOTOR OR THE AREA TYPE FAN.
  - ⚠ 22 & 23 = NORMALLY OPEN END SWITCH ON DAMPER (CLOSES WHEN DAMPER IS FULLY OPEN).
- NOTE - DAMPER MUST OPEN WITHIN 2 MINUTES FOR PROPER OPERATION OF GTS.

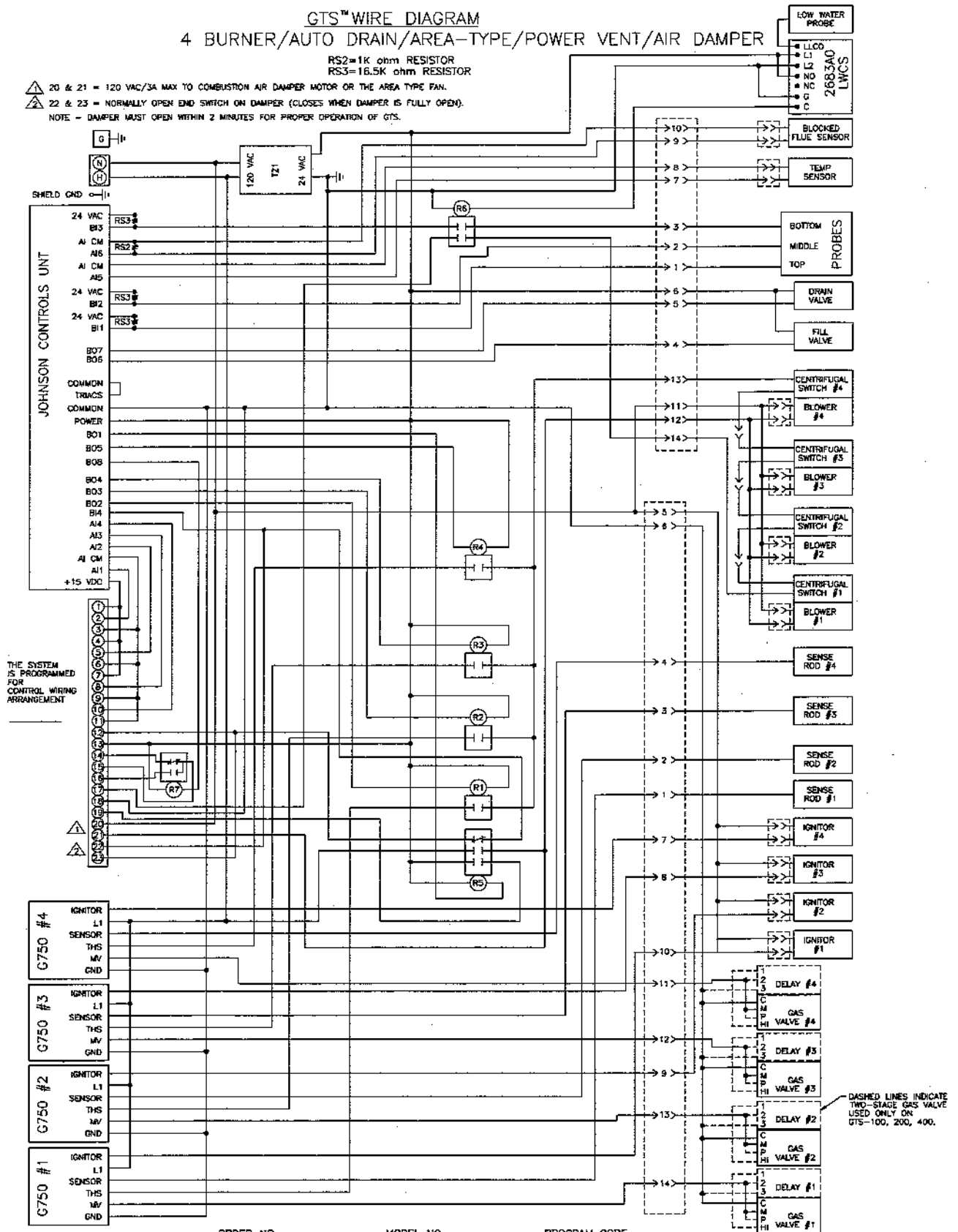

THE SYSTEM IS PROGRAMMED FOR CONTROL WIRING ARRANGEMENT

DASHED LINES INDICATE TWO-STAGE GAS VALVE USED ONLY ON GTS-100, 200, 400.

ORDER NO.: \_\_\_\_\_ MODEL NO.: \_\_\_\_\_ PROGRAM CODE: \_\_\_\_\_

# SAMPLE GTS™ WIRING DIAGRAM

## GTS™-DI WIRE DIAGRAM

### 4 BURNER/MANUAL DRAIN/AREA-TYPE/POWER VENT/AIR DAMPER

RS2=1K ohm RESISTOR RS3=16.5K ohm RESISTOR

- ⚠ 20 & 21 = 120 VAC/3A MAX TO COMBUSTION AIR DAMPER MOTOR OR THE AREA TYPE FAN.
- ⚠ 22 & 23 = NORMALLY OPEN END SWITCH ON DAMPER (CLOSES WHEN DAMPER IS FULLY OPEN).
- NOTE - DAMPER MUST OPEN WITHIN 2 MINUTES FOR PROPER OPERATION OF GTS.

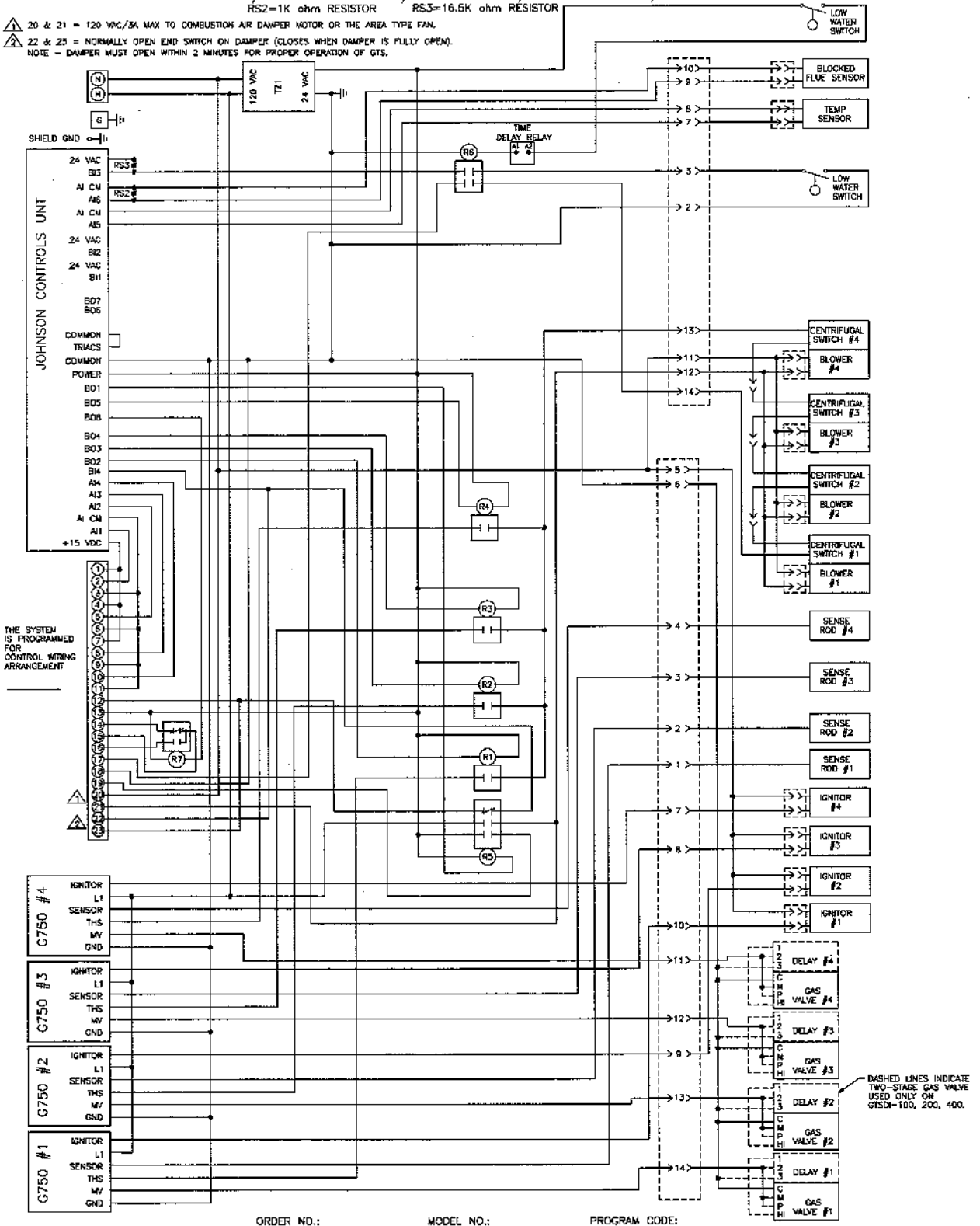

THE SYSTEM IS PROGRAMMED FOR CONTROL WIRING ARRANGEMENT

DASHED LINES INDICATE TWO-STAGE GAS VALVE USED ONLY ON GTS-DI-100, 200, 400.

ORDER NO.: \_\_\_\_\_ MODEL NO.: \_\_\_\_\_ PROGRAM CODE: \_\_\_\_\_

## TROUBLE-SHOOTING GUIDE

SYMPTOM	DISPLAY MESSAGE	POSSIBLE CAUSE	RECOMMENDED ACTION
HUMIDIFIER WILL NOT FILL	ERROR 3	No water pressure	Verify manual water supply valve open and minimum 25 psi supply pressure.
		Faulty water fill valve	Verify voltage present at fill valve coil. Audible click should be heard as solenoid operates.
		Plugged fill valve	Clean valve.
		Plugged strainer	Clean strainer.
HUMIDIFIER DOES NOT STOP FILLING	ERROR 5	Fill valve is stuck open	Check valve for foreign matter.
	ERROR 5	Fill valve installed backwards	Check arrow direction on strainer, "In" should be visible on fill valve body.
	ERROR 5	Water probes have not proven	Drain valve may be stuck open, clean or replace valve. Water purity is not conductive for probe system, add salt or convert to D.I. control.
UNIT SHORT CYCLES		Probes may be incorrectly wired or need cleaning	Confirm that unit is wired per diagram. Clean probe rod tips with steel wool.
BLOWER(S) WILL NOT OPERATE	NO DISPLAY	No voltage to blower(s)	Verify main power supply.
	ANY ERROR	No voltage to blower(s)	Verify power to blowers.
	ANY ERROR	Error code displayed on ZTU screen	Verify error code and correct fault.
	N.A.	No call for humidity	Check humidifier control for demand, set point may be lower than actual.
WATER FLOAT VALVE DOES NOT CLOSE		Open drain valve	Obstruction in drain valve will not allow complete closure, clean or replace valve.
		Manual drain valve not closed	Close drain valve.
		Malfunctioning Float Valve	Float ball has water leak. Float valve seat defective, replace.
		Water passing into overflow stand pipe.	Readjust float valve rod, so water level reaches 1/4-3/8" from over flow edge when water is at ambient or cold state. Excessive water pressure, 100 psi maximum.
		Float valve stuck	Obstruction will not allow float valve to seat properly, clean or replace with new seat.

## TROUBLE-SHOOTING GUIDE

SYMPTOM	DISPLAY MESSAGE	POSSIBLE CAUSE	RECOMMENDED ACTION
BURNER(S) WILL NOT LIGHT, BLOWERS OPERATING	N.A.	No gas supply to unit	Verify gas service valve on and minimum pressure to manifold per rating plate.
	NA	Gas valve off or no power to valve	Verify valve in "on" position and power to valve.
	NA	Broken ignitor	Verify ignitor glows.
	NA	Gas valve/ignitor/sensing electrode out of sequence	Verify wire connections to these components.
	NA	Gas valve outlet pressure too low	Verify outlet pressure is set per rating plate.
	NA	Blower shutter open too far	Reference O&M manual maintenance section (air shutter adjustment procedure).
	NA	Blower inlet dirty or obstructed	Clean inlet and check for obstructions.
	NA	Shutdown mode	Normal - 2 minute delay w/blower shut down.
	NA	Malfunctioning centrifugal switch	Check centrifugal switches for continuity with blower running.
BURNER(S) LIGHT BUT BURN BLUE (DON'T GO INFRA-RED)	NA	Too lean condition	Reference O&M manual maintenance section (air shutter adjustment procedure).
LOW OUTPUT	NA	All burners not fired	May be normal based on set point. Verify that burner fire on full call. Flame rod not sensing flame. Mineral accumulation in tank.

## TWO-YEAR LIMITED WARRANTY

DRI-STEEM Humidifier Company ("DRI-STEEM") warrants to the original user that its products will be free from defects in materials and workmanship for a period of two (2) years after installation or twenty-seven (27) months from the date DRI-STEEM ships such product, whichever date is the earlier.

If any DRI-STEEM product is found to be defective in material or workmanship during the applicable warranty period, DRI-STEEM's entire liability, and the purchaser's sole and exclusive remedy, shall be the repair or replacement of the defective product, or the refund of the purchase price, at DRI-STEEM's election. DRI-STEEM shall not be liable for any costs or expenses, whether direct or indirect, associated with the installation, removal or re-installation of any defective product.

DRI-STEEM's limited warranty shall not be effective or actionable unless there is compliance with all installation and operating instructions furnished by DRI-STEEM, or if the products have been modified or altered without the written consent of DRI-STEEM, or if such products have been subject to accident, misuse, mishandling, tampering, negligence or improper maintenance. Any warranty claim must be submitted to DRI-STEEM in writing within the stated warranty period.

DRI-STEEM's limited warranty is made in lieu of, and DRI-STEEM disclaims all other warranties, whether express or implied, including but not limited to any IMPLIED WARRANTY OF MERCHANTABILITY, ANY IMPLIED WARRANTY OF FITNESS FOR A PARTICULAR PURPOSE, any implied warranty arising out of a course of dealing or of performance, custom or usage of trade.

DRI-STEEM SHALL NOT, UNDER ANY CIRCUMSTANCES BE LIABLE FOR ANY DIRECT, INDIRECT, INCIDENTAL, SPECIAL OR CONSEQUENTIAL DAMAGES (INCLUDING, BUT NOT LIMITED TO, LOSS OF PROFITS, REVENUE OR BUSINESS) OR DAMAGE OR INJURY TO PERSONS OR PROPERTY IN ANY WAY RELATED TO THE MANUFACTURE OR THE USE OF ITS PRODUCTS. The exclusion applies regardless of whether such damages are sought based on breach of warranty, breach of contract, negligence, strict liability in tort, or any other legal theory, even if DRI-STEEM has notice of the possibility of such damages.

By purchasing DRI-STEEM's products, the purchaser agrees to the terms and conditions of this limited warranty.

Metasys® is a registered trademark of Johnson Controls.

RAPID-SORB™ and GTS™ are trademarks of DRI-STEEM Humidifier Company.

ULTRA-SORB® is a registered trademark of DRI-STEEM Humidifier Company.

Continuous product improvement is a policy of DRI-STEEM therefore, product features and specifications are subject to change without notice.

**DRI STEEM**  
HUMIDIFIER COMPANY

14949 Technology Drive • Eden Prairie, MN 55344  
Telephone: 1-800-328-4447 • In MN: (612) 949-2415  
Fax: (612) 949-2933 • E-Mail: sales@dristeem.com



Printed on recycled paper with  
agri-based inks. Minimum 10%  
Post Consumer Waste.

