

READ AND SAVE THESE INSTRUCTIONS

HUMIDIFLO®

EVAPORATIVE HUMIDIFIERS

Installation Instructions and Maintenance Operations

(The standard HUMIDIFLO unit requires water conductivity to function and therefore will not operate on water treated by the reverse osmosis or deionizing process. Consult factory for assistance if you plan to use these water types.)

CSA & UL LISTED

<u>INDEX FOR HUMIDIFLO EVAPORATIVE HUMIDIFIER</u>	<u>Page Number</u>
HOW THE HUMIDIFLO OPERATES	2
DUCTING	3
MOUNTING METHODS	4
RECOMMENDED PIPING DIAGRAM .	5
DIMENSIONS	5
CAPACITIES	6
PARTS LIST	6
WIRING DIAGRAMS	7
MAINTENANCE PROCEDURE	8

pg 6 —
Contractor mis-spelled as
Contractor



HUMIDIFLO WARRANTY

DRI-STEEM HUMIDIFIER COMPANY guarantees every HUMIDIFLO humidifier:

1. To be manufactured of material as advertised and to be free of defects. We agree to replace any parts that are found to be defective within one year from the date of sale.
2. To function as claimed in product literature and to produce catalog capacities when properly installed.
3. The above provisions are in lieu of all other guarantees, obligations, liabilities or warranties, expressed or implied.

How the HUMIDIFLO operates.

When the relative humidity of the humidified area drops below the desired level, the Humidistat Control calls for humidity. This starts the circulator (in the hot water type) and the fan. Hot water, drawn from a water heater or boiler, is pumped through the heat exchanger, heating the water in the chamber and causing evaporation.

The fan circulates air through the chamber. This air picks up the water vapor and discharges it into the area to be humidified.

When the level of humidity in the area satisfies the Humidistat Control, the circulator and the fan are automatically shut off.

The operation of the Electric Heated HUMIDIFLO is essentially the same. The electric heating element (instead of a circulator and heat exchanger) is cycled on and off in the same manner.

Reliable, electronic probe control of water cycles.

A simple, 3-prong, conductivity probe controls water level and fill cycles, through a solenoid operated, water fill valve.

When the HUMIDIFLO evaporating chamber is empty and the power is turned on, a solenoid operated fill valve opens and the chamber begins to fill. When the

To the installer

Before you install this unit, please read the instructions carefully. The unit is designed to operate on a 120 volt, 60 cycle AC power supply. The unit is designed to operate on a 120 volt, 60 cycle AC power supply. The unit is designed to operate on a 120 volt, 60 cycle AC power supply.

The unit is designed to operate on a 120 volt, 60 cycle AC power supply. The unit is designed to operate on a 120 volt, 60 cycle AC power supply. The unit is designed to operate on a 120 volt, 60 cycle AC power supply.

water reaches level "A", a call for humidity by the humidistat will start the circulator (hot water unit) or energize the electric heater (electric unit), the fan will start, and the fill valve will close. For proper operation 100 micromhos/cm (2 gr/gal) conductivity minimum is needed.

Low water protection.

As water evaporates, the water line gradually drops to level "B". The fill valve then re-opens and the chamber is refilled to level "A". (See side view section, below.)

Each time the water reaches level "B", the HUMIDIFLO fan and circulator (or electric heater) shut down and remain so until the unit has refilled to level "A". This provides low water protection in the event of make-up water supply failure.

The HUMIDIFLO, therefore, is normally idle during refill (about 3% of the "on" time).

Each time the evaporating chamber is replenished with water, the surface is drained through a skimming port in a standpipe, removing the floating mineral residue. (Much like the surface blowdown on a steam boiler.) The skimming port is about 1/4" below level "A".

In other words, each "refill" is followed by a "skim." The removal of floating mineral residue is an on-going process. Also, the unit cannot overflow. Should the fill valve fail to close, water would drain through the open top of the standpipe.

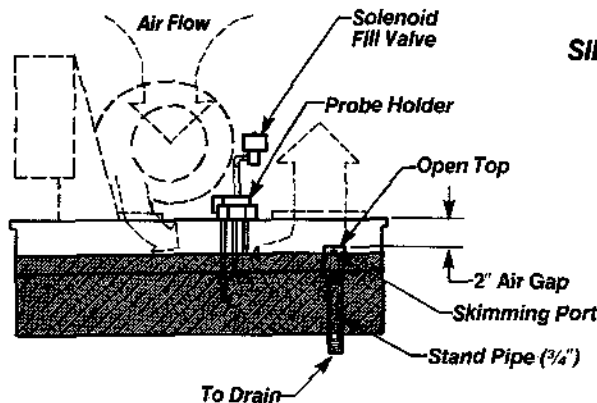

SIDE VIEW SECTION OF HUMIDIFLO

A = Level At Which Fill Valve Closes And Unit Starts Up.

B = Level At Which Fill Valve Opens And Unit Shuts Down.

C = Unit Common

For metric conversion: inches \times 25.4 = mm

Ducting.

The HUMIDIFLO is designed with a 6" diameter discharge duct collar. When a discharge duct is used, it should be installed *inside* the collar. This permits any condensation to drain back into the HUMIDIFLO unit, rather than onto the floor.

All ducts should be pitched *back* to the unit and all joints sealed with waterproof duct tape.

Connecting the HUMIDIFLO to a duct system.

The fan of the HUMIDIFLO is *not* intended to overpower significant external static pressure. When discharging from the unit to a duct system where the external pressure exceeds .25" W.C., the fan should draw from the same system.

Ducting notes.

1. DO NOT connect HUMIDIFLO inlet and outlet ducts where a significant static pressure differential exists between them, such as on either side of a filter bank as shown in the "incorrect" example below. Such connections may adversely affect the air velocity through the HUMIDIFLO.
2. Inlet air to HUMIDIFLO should be taken off main duct *upstream* of humidified air from HUMIDIFLO.
3. An air flow proving device should be provided so that HUMIDIFLO cannot operate unless air is flowing in main duct.

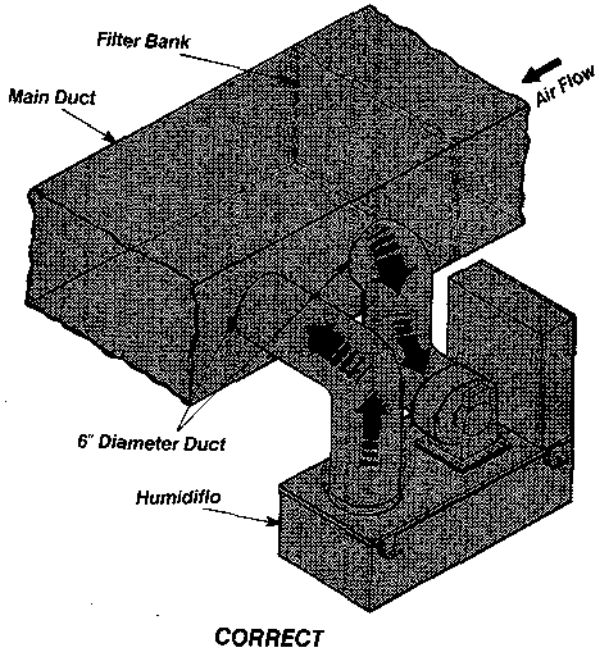
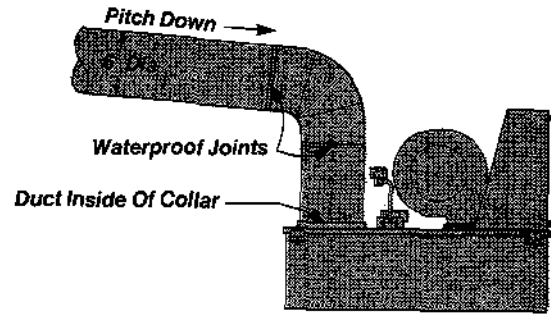

CORRECT

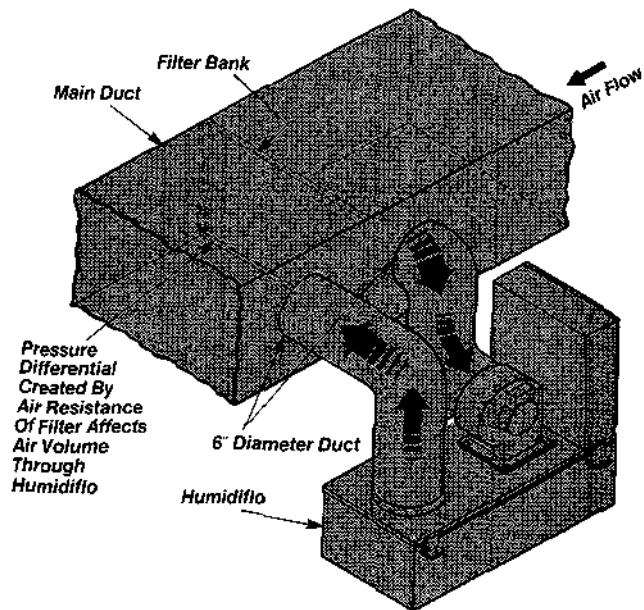

INCORRECT

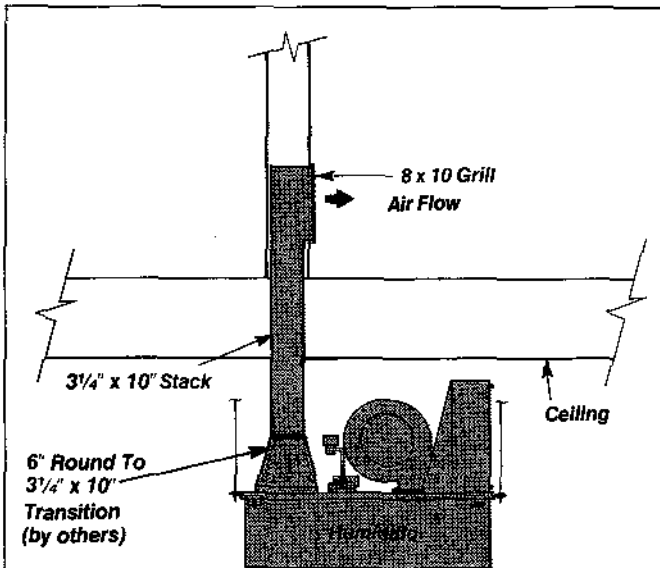

Note: Unit Must Be Level In Both Directions.
Dry Weight Approx. 68 Lbs.
Operating Weight Approx. 125 Lbs.

Ceiling installation ducting.

In this type of installation, humidified air should discharge into a space where the water vapor is free to disperse. For example, a large room or hall where doors are always left open. The humidistat should not be in the direct path of the humidified air stream nor should it be isolated by distance or a closed door.

For metric conversion: inches \times 25.4 = mm

Typical Installations.

The HUMIDIFLO's compact size and light operational weight allow a great deal of flexibility in installation and mounting. The unit may be mounted on brackets attached to a wall or suspended from overhead construction by rods, pipe-straps or heavy wire. (If no discharge ducting is used an elbow must be connected to duct collar of unit and a minimum of 3'-0" must be maintained from nearest obstruction.) It can also be mounted on a separate stand (optional), provided by DRI-STEEM, and built to meet the specific requirements of the job or location. For installation in finished spaces an optional, attractively styled cabinet enclosure is available. Operation of the HUMIDIFLO is dependent on a water source, an electricity source and drain facilities. Location will be determined by the availability of these sources and by auxiliary mechanicals, such as ductwork and air handling equipment. *And* by the humidification requirements of the area to be humidified.

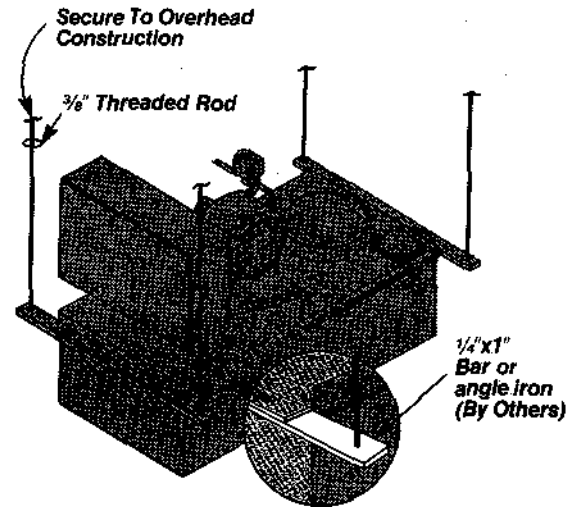

NOTE: Unit must be level in both directions
 Empty weight: Approx. 68 lbs.
 Operating weight: Approx. 125 lbs.

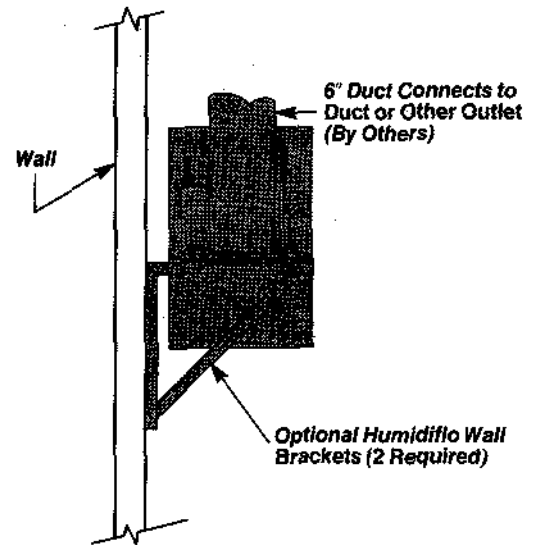

For metric conversion: inches x 25.4 = mm

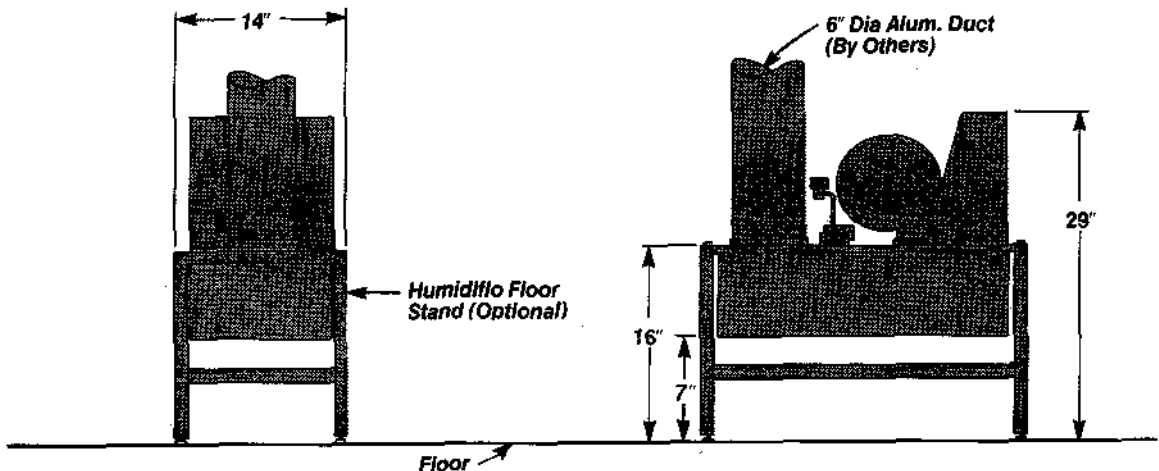

Piping for HUMIDIFLO. (Hot water or electric heated)

Notes:

- 1) When installing the HUMIDIFLO in an existing hot water heating system, the pumping capacity of the existing circulator may be sufficient to handle the additional requirements of the HUMIDIFLO (5 gpm). If so, an on/off type zone valve may be substituted for a separate, additional circulator.
- 2) Provide a shut off valve. Connect to fill water supply with 1/4" O.D. tubing. Where house pressure exceeds 50 psi, a shock arrester may be advisable, to eliminate water hammer. Generally, unsoftened water is preferred over softened water.
- 3) The standpipe drain connection in the HUMIDIFLO is 3/4" I.P.S. Extend to the floor drain or other suitable outlet. A union or funnel drain in this line is recommended, to permit chamber removal for maintenance.
- 4) The bottom drain is 1/2" I.P.S. It is recommended that this line be valved and connected to the standpipe drain line to simplify drainage for servicing.
- 5) Piping to an Electrically Heated HUMIDIFLO is identical, with the exception of circulating water piping.

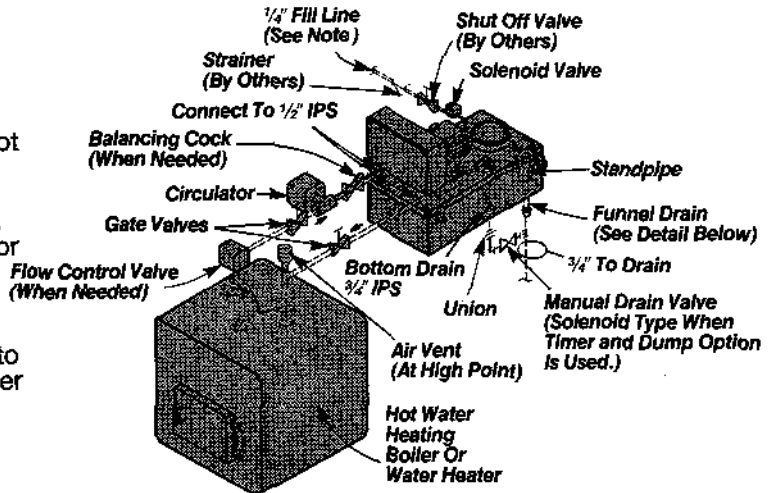

Note: All Dashed Piping By Installer

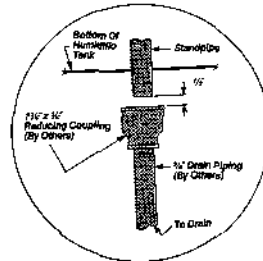

For metric conversion:
inches x 25.4 = mm

DIMENSIONS

HOT WATER HEATED

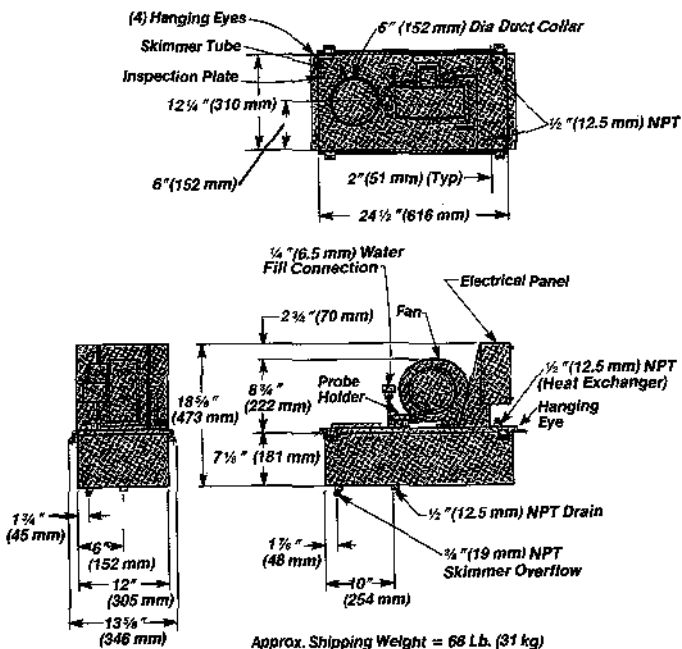

ELECTRIC HEATED

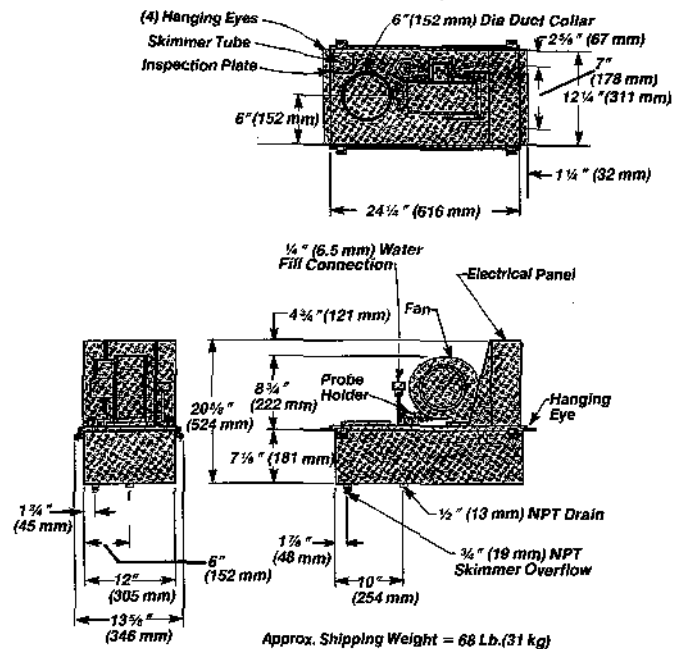

CAPACITIES

Hot Water Heated

Based on make-up water at 50° F
and air at 70° F. Flow rate = 5 gpm.
Head = 5'-0"
Fan 160 cfm, 2013 F/S Tip Speed

Model #	Heating Water Temperature		† Vapor Output (per hour)		
	°F	°C	Lbs	Gallons	Kg
HW120	120	48.9	5.5	.66	2.49
HW130	130	54.4	7.7	.92	3.49
HW140	140	60.0	8.9	1.07	4.04
HW150	150	65.6	11.6	1.39	5.26
HW160	160	71.1	13.5	1.62	6.12
HW170	170	76.7	15.5	1.86	7.03
HW180	180	82.2	17.8	2.14	8.07
*HW190	190	87.8	20.5	2.48	9.30
*HW200	200	93.3	23.4	2.81	10.61
*HW210	210	98.9	26.1	3.13	11.84

*Models furnished with 265 cfm fan, 2158 F/S Tip Speed
Supply 120 volt, 1 ∅, 2 amp, 50/60 Hz

Electric Heated

Fan 160 cfm, 2013 F/S Tip Speed

Model #	Heat Source	Heater Supply Input •				†Output (Hourly)		
		Single Phase		Three Phase		Lbs	Gal	Kg
		Volts	Amps	Volts	Amps**			
HE 200	2000 Watts	120 ▲	17.0	—	—	5.8	.7	2.6
		208	9.6	—	—			
		240	8.3	—	—			
		480	4.2	—	—			
HE 300	3000 Watts	208	14.4	—	—	8.7	1.05	3.9
		240	12.5	—	—			
		480	6.3	—	—			
		208	19.2	208	16.7			
240	16.7	240	14.4					
480	8.3	480	7.2					
600	6.0	600	6.0					
HE 500	5000 Watts	208	24.0	208	21.0	14.5	1.75	6.5
		240	20.8	240	18.2			
		480	10.4	480	9.1			
		600	9.0	600	9.0			
HE 600	6000 Watts	208	28.8	208	25.0	17.5	2.1	7.9
		240	25.0	240	21.7			
		480	12.5	480	10.8			
		600	9.0	600	9.0			
HE 700	7000 Watts	208	33.7	208	21.0	20.3	2.45	9.1
		240	29.2	240	18.2			
		480	14.6	480	9.1			
		600	9.0	600	9.0			
*HE 800	8000 Watts	208	38.5	208	25.0	23.3	2.8	10.5
		240	33.3	240	21.7			
		480	16.7	480	10.8			
		600	9.0	600	9.0			
*HE 900	9000 Watts	208	43.3	208	25.0	26.2	3.16	11.8
		240	37.5	240	21.7			
		480	18.8	480	10.8			
		600	9.0	600	9.0			

*Models furnished with 265 cfm fan, 2158 F/S Tip Speed

Note:

All HUMIDIFLOS operate on 50/60 hertz and require separate control circuit supply (120 volt, single phase) in addition to heater supply input

▲ Exception: Does not require separate control circuit supply.

• Customer must provide equipment ground per local electrical code.

† Based on 85% efficiency (15% loss due to skimming and conducted heat loss).

** For wire sizing. Highest line draw is shown due to current unbalance in some cases.

HUMIDIFLO Parts List For hot water and electric heated models

Description	Qty.
Circulation Fan 265 cfm	1
Circulation Fan 160 cfm	1
Heater 2000 Watt, Specify Voltage	1-3
Heater 3000 Watt, Specify Voltage	1-3
Contractor 30 amp, 24 volt coil	1
Contractor 40 amp, 24 volt coil	1
Control Fuse 3 amp	1
Control Relay 24 volt coil DPDT contacts	1
Control Relay 24 volt coil 3DPT contacts	1
Control Transformer 38VA, Class 2	1
Solenoid Valve 24 Vac "FILL", 1/4" NPT	1
Solenoid Valve 24 Vac "DRAIN", 3/4" NPT	1
Electronic liquid level control board	1
Electronic drain-down timer board	1
Probe Gasket	1
Fan Gasket (265 cfm)	1
Fan Gasket (160 cfm)	1
Heater Mtg. Gasket	1
Tank Gasket Set	1
Inspection Port Gasket	1

HUMIDIFLO WIRING DIAGRAMS

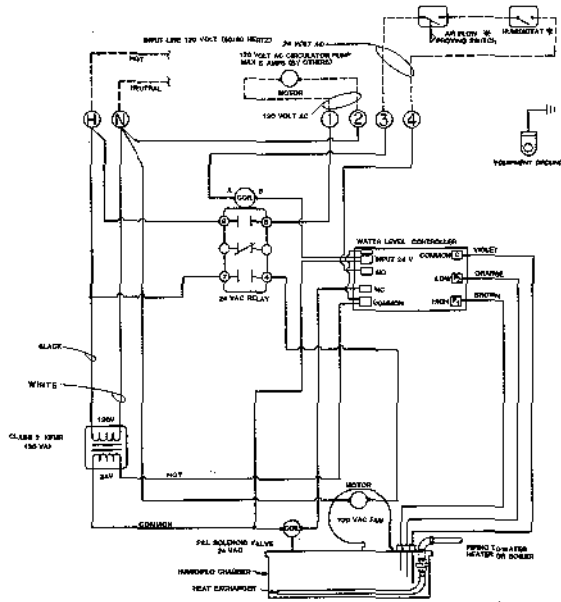

Hot water heated model (120 volt only)

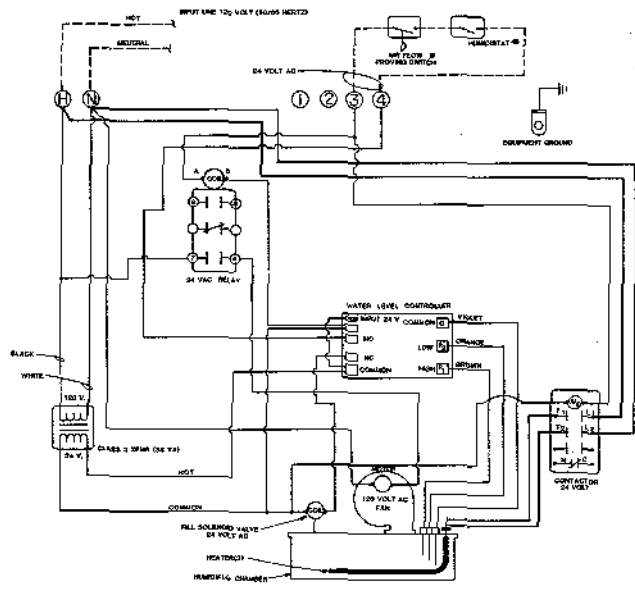

Model HE-200 (120 input voltage only)

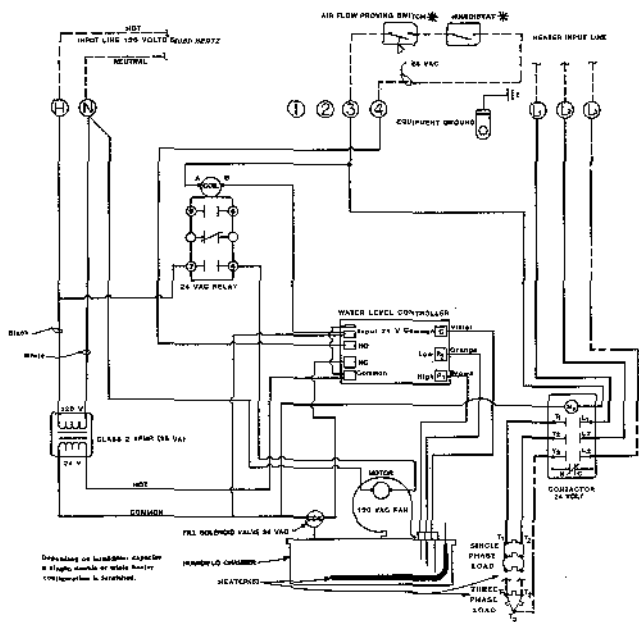

Model HE series Single and Three phase

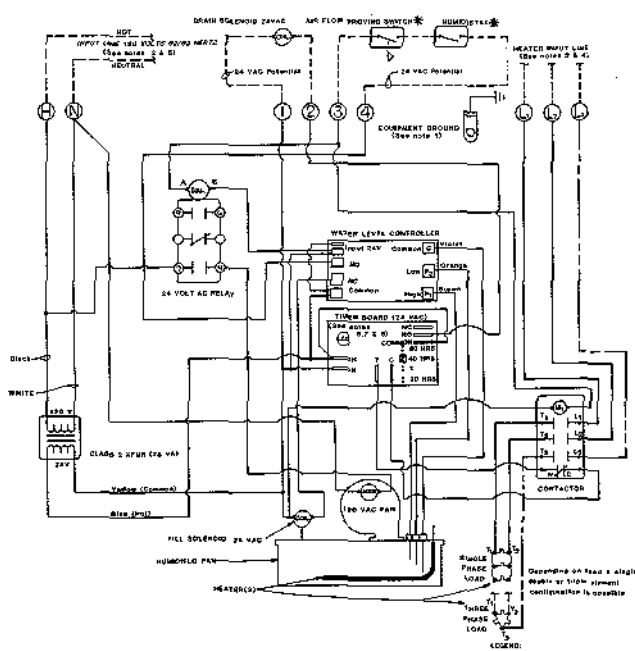

**Model HE series Single and Three phase
(With timer/drain down option)**

- * Optional
- Control circuit wiring
- Power wiring
- Field Wiring

MAINTENANCE PROCEDURE

- 1) Circulator — Oil annually.
- 2) HUMIDIFLO Fan Motor — Oil annually.
- 3) Adjusting the Surface Skimmer —

The elevation of the skimmer openings in the side of the threaded pipe coupling on the skimmer tube, in respect to the operating water line, determines the amount of "skim" water that flows to drain with each water make-up cycle. This elevation, and therefore the quantity of the "skim" water, is adjustable and obviously, if more "skimming water" is used than is necessary to keep the unit clean, the excess is simply waste.

Minerals Precipitate

As evaporation takes place in the HUMIDIFLO, some of the minerals dissolved in the water precipitate (come out of solution) and float on the water surface. If not removed, this precipitated mineral will eventually form a sludge inside of the HUMIDIFLO.

Skimmer Removes Precipitated Mineral

Each time the make-up valve opens, the unit refills to a point just above the skimmer openings. A portion of the make-up is then "skimmed" (flows to drain), carrying the floating mineral with it. This action reduces the mineral concentration in the HUMIDIFLO which, in turn, reduces the required frequency of cleaning. When properly adjusted, once-a-season cleaning is usually adequate, assuming water having a hardness of up to 15 grains of dissolved mineral per gallon.

Too Much Skimming is Wasteful

The heated water that flows to drain is a cost of operation but, of course, time spent in cleaning the HUMIDIFLO is also a cost. It is recommended, therefore, that at the time of start up, the user adjust the skimming quantity. By observing the mineral buildup and adjusting the skim quantity at one week intervals over the span of a month or so, an acceptable balance between skim water quantity and rate of mineral buildup can be achieved.

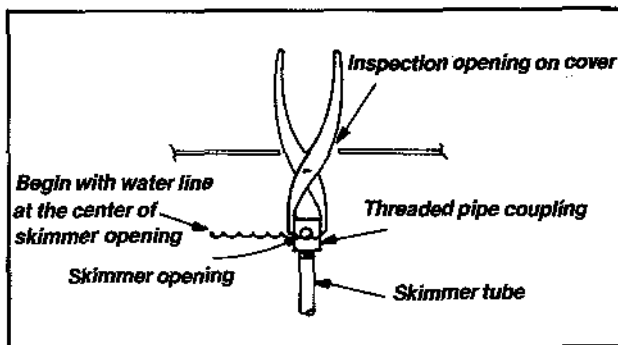

Adjusting the Drain Hole Height

To adjust, simply remove the inspection cover, reach in with a long nose pliers and grasp the coupling, rotate it to raise or lower the skimmer openings as desired.

Note: In cases where extremely hard water is used, (significantly above 15 grains per gallon) the surface skimmer may not adequately control mineral buildup. A timer and "dump" valve (available as an option) are recommended for these cases.

4) Cleaning the Evaporating Chamber and Heat Exchanger (hot water heated) —

Remove the inspection cover and inspect for mineral accumulation (scale) on heat exchanger at four week intervals. When the accumulation is $\frac{1}{8}$ " thick or when output falls off noticeably (HUMIDIFLO runs constantly), the scale should be removed.

To remove it, lower the chamber, disconnect the heat exchanger and place in the chamber for soaking. Fill the chamber, as required, to submerge scaled parts in a calcium dissolving solution, let soak as required, brush or scrape the scale from the heat exchanger and chamber, rinse thoroughly especially the *inside* of heat exchanger when used on a water heater application. This is to prevent solvent from getting into the water heater. Re-assemble and place back in service.

Note: Step 4 (cleaning) should be done at least annually.

5) Cleaning the Evaporating Chamber (electric) —

Remove inspection cover and inspect for mineral flake (scale) accumulation at four week intervals. The heating element itself is usually self cleaning since it operates at a much higher temperature than the hot water unit, and so the mineral buildup on the element flakes off after reaching a thickness of about $\frac{1}{16}$ ", and settles to the bottom of the chamber. Before scale accumulation builds up to the underside of the heating element, it should be removed.

To remove loose scale, lower the chamber and scoop it out. Scale adhering to the walls of the chamber can be removed by scraping but may require softening with a calcium dissolving solution.

Note: Step 5 (cleaning) should be done at least annually.

6) Electrodes (level control) —

Being teflon coated, except for the tip, the scale flakes off easily.

The buildup on the tips should be brushed or scraped off at least annually.

7) Off Season Shut Down (hot water heated) —

- a. Switch off power.
- b. Valve off water supply to make-up valve.
- c. Valve off supply and return to heat exchanger.
- d. Drain evaporating chamber and remove scale accumulation (scale hardens and becomes more difficult to remove after exposure to air).

Leave chamber empty, power off and valves closed until the next humidification season.

Electric Heated

- a. Switch off power.
- b. Valve off water supply to make-up valve.
- c. Drain evaporating chamber and remove scale accumulation.

Leave chamber empty, power off and valve closed until the next humidification season.