

---

**DRI STEEM<sup>®</sup>**

**LTS<sup>®</sup>**

Liquid-to-Steam Humidifier

**Installation, Operation  
and Maintenance Manual**



*from the Humidification Experts*

# Table of contents

## Product overview

Product overview .....	3
LTS dimensions .....	4
LTS output capacities .....	6
LTS weights, connections and heated water properties .....	7

## Installation

Selecting a location for the LTS .....	8
LTS clearance recommendations .....	9
Mounting methods .....	10
Trapeze hanger .....	11
Support legs .....	12
H-legs .....	12
Wall brackets .....	13
LTS piping overview .....	14
Drain piping .....	16
Alternate water seal and drain valve piping .....	17
Water supply piping .....	18
LTS wiring .....	20
Dispersion .....	23
Selecting the dispersion assembly location .....	23
Interconnecting piping requirements .....	24
Drip tee installation .....	26
Single Tube and Multiple Tube .....	27
RAPID-SORB .....	31

## Operation

Start-up procedures .....	38
Start-up: LW417 control .....	39
LW417 automatic drain and flush .....	40
LW417 variable skim times .....	41
LW417 end-of-season drain .....	41
LW417 onboard diagnostics .....	41

## Maintenance

LTS standard water model maintenance .....	42
Adjusting skim duration .....	42
LTS DI water model maintenance .....	46
Troubleshooting .....	48
Replacement parts .....	51
LTS maintenance service record .....	55
Two-year limited warranty .....	56

## Product overview

**Figure 3-1:**  
**LTS standard water model**

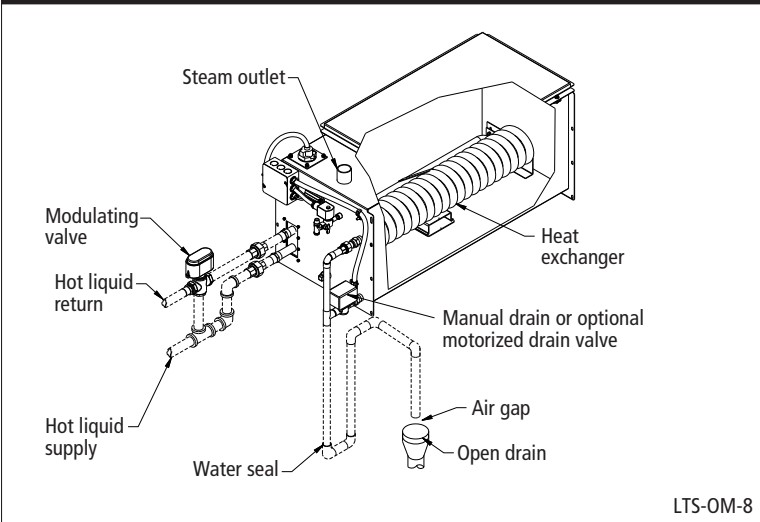

**Figure 3-2:**  
**LTS DI/RO water model**

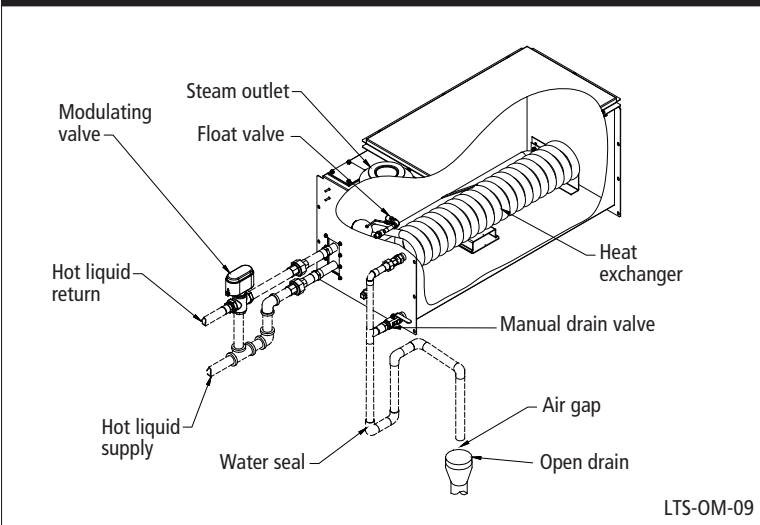

### Standard water models (LTS)

Standard water LTS humidifiers heat potable or softened fill water into steam for humidification. A conductivity probe controls water level, requiring water conductivity to be at least 100  $\mu\text{S}/\text{cm}$  (2 grains/gallon) to operate properly. Therefore, standard water LTS models will not operate with demineralized water. For demineralized water operation (using deionized or reverse osmosis treated water), use LTS-DI model humidifiers (described below).

### Deionized water models (LTS-DI)

LTS-DI humidifiers heat deionized (DI) or reverse osmosis (RO) fill water into steam for humidification. LTS-DI models control water levels using a float valve.

### Notes:

- Damage caused by chloride corrosion is not covered by your DRI-STEEM warranty.
- LTS standard water models can be converted in the field for use with deionized/reverse osmosis (DI/RO) water. LTS-DI models can be converted in the field for use with potable or softened water.
- Drain piping material must be suitable for 212 °F (100 °C) water.
- Dashed lines in drawings indicate provided by installer.

## LTS dimensions

**Figure 4-1:**  
**Dimensions, LTS models 25C and 100C (one heat exchanger)**

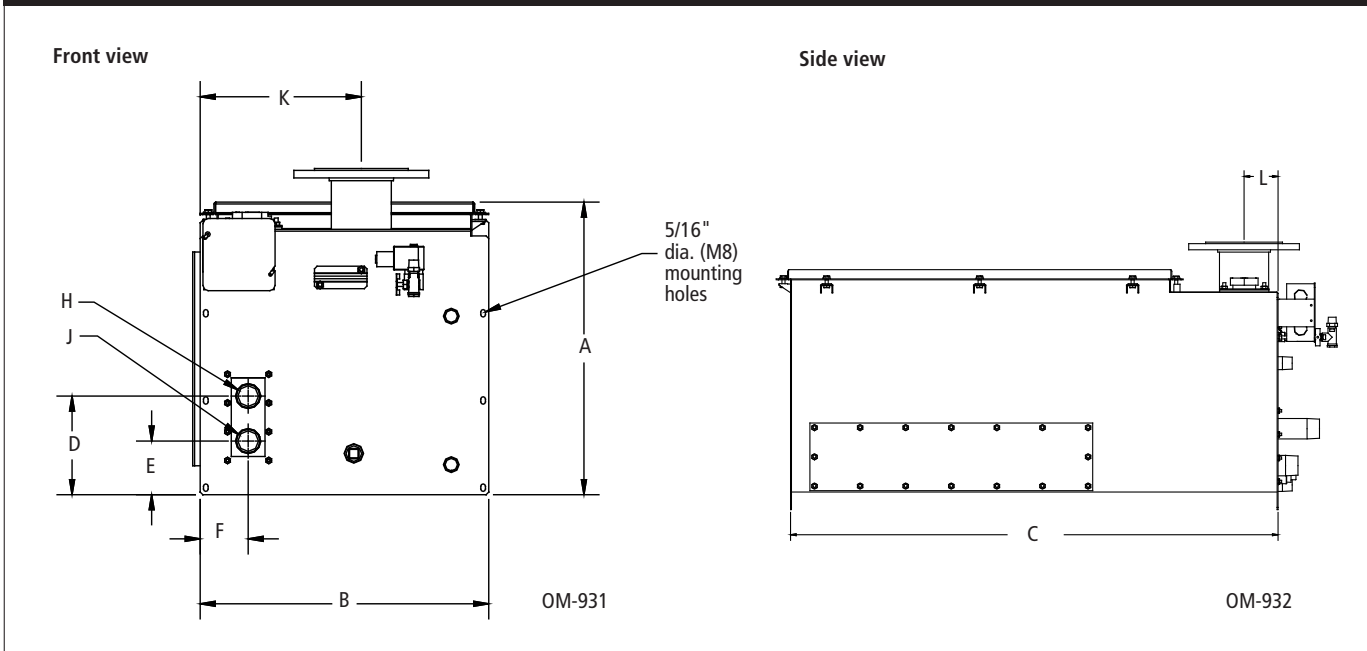

**Table 4-1:**  
**LTS dimensions**

	Description	LTS model number			
		25C		100C	
		inches	mm	inches	mm
A	Overall height*	19.50	495	19.50	495
B	Face width	14.75	375	19.25	490
C	Face length	23.83	605	39.65	1007
D	Distance from bottom to return outlet of heat exchanger	6.67	169	6.67	169
E	Distance from bottom to supply inlet of heat exchanger	3.67	93	3.67	93
F	Distance from side to heat exchanger	3.20	80	3.20	80
H	Hot liquid return outlet	1.00	25	1.00	25
J	Hot liquid supply inlet	1.00	25	1.00	25
K	Distance from side to steam outlet	7.38	187	10.75	273
L	Distance from front to steam outlet	2.50	64	2.75	70

**Notes:**

\* Add 23.5" (597 mm) to overall height when LTS is mounted on optional support legs.  
 C = Copper heat exchanger with nickel coating

# LTS dimensions

**Figure 5-1:  
Dimensions, LTS models 400C (two heat exchangers)**

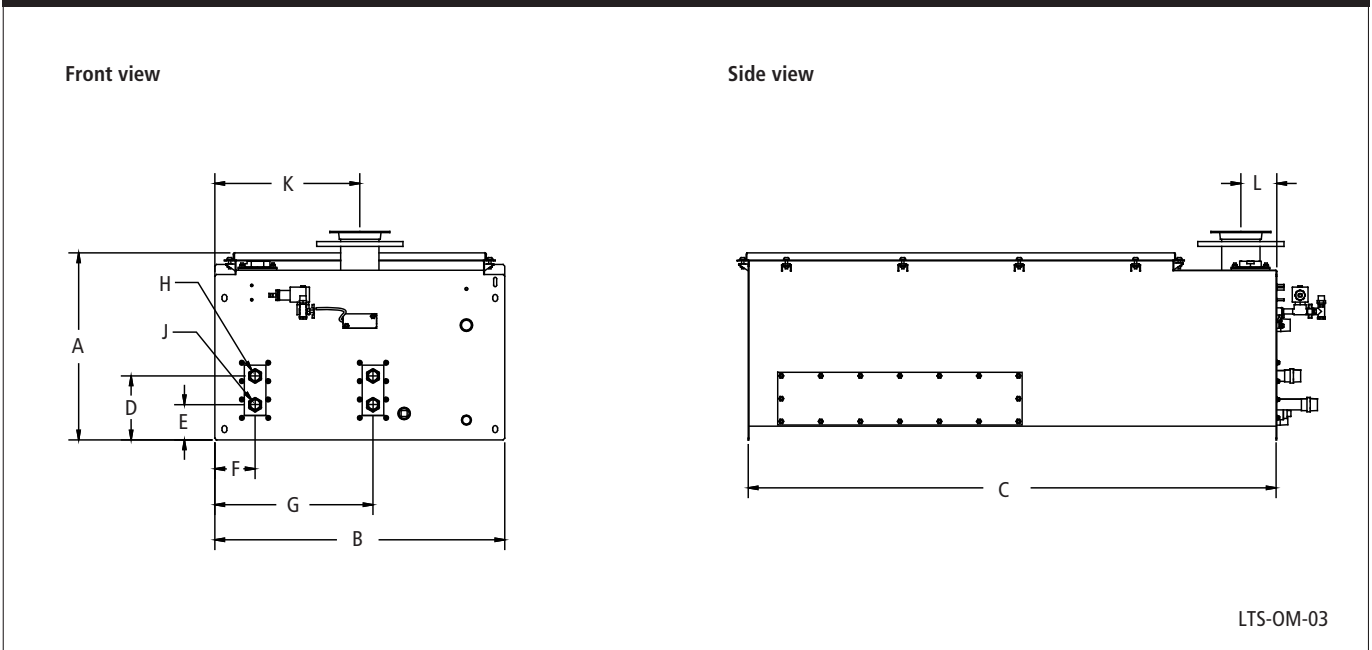

**Table 5-1:  
LTS dimensions**

Description	LTS model		
	400C		
	inches	mm	
A	Overall height*	19.50	495
B	Face width	30.25	768
C	Face length	55.15	1401
D	Distance from bottom to return outlets of heat exchangers	6.67	169
E	Distance from bottom to supply inlets of heat exchangers	3.67	93
F	Distance from side to first heat exchanger	4.20	107
G	Distance from side to second heat exchanger	16.50	419
H	Hot liquid return outlet	1.00	25
J	Hot liquid supply inlet	1.00	25
K	Distance from side to steam outlet	15.13	384
L	Distance from front to steam outlet	3.75	95

**Notes:**

\* Add 22.5" (572 mm) for total height with H-legs.

C = Copper heat exchanger with nickel coating

## LTS output capacities

**Table 6-1:  
LTS output capacities using hot water**

LTS model number	Flow		Output (lbs/hr and kg/h)								Pressure drop through heat exchanger	
			Hot water supply temperature									
	gpm	L/m	240 °F	116 °C	250 °F	121 °C	260 °F	127 °C	280 °F	138 °C	psi	kPa
25C	8	30	25	11	45	20	65	29	100	45	1.5	10
	10	38	32	15	53	24	74	34	116	53	1.8	12
	12	45	40	18	60	27	85	39	135	61	2.0	14
	15	57	50	23	75	34	105	48	160	73	2.5	17
	17	64	60	27	90	41	120	54	170	77	3.0	21
100C	8	30	50	23	70	32	95	43	150	68	2.4	17
	10	38	60	27	80	36	108	49	172	78	3.2	22
	12	45	70	32	90	41	120	54	195	88	4.0	28
	15	57	85	39	110	50	140	64	230	104	6.0	41
	17	64	95	43	125	57	155	70	250	113	8.0	55
400C*	20	76	150	68	205	93	265	120	420	191	5.0	34.5
	24	91	190	86	250	113	310	141	470	213	6.0	41
	30	114	240	109	300	136	350	159	510	231	8.0	55
	34	129	260	118	320	145	380	172	540	245	10.0	69

**Notes:**

\* Two heat exchangers and two valves  
 C = Copper heat exchanger with nickel coating  
 The LTS is not ASME-certified.

# LTS weights, connections and heated water properties

**Table 7-1:  
LTS connection sizes**

Description	Connection size
Water makeup (fill)	1/4" pipe thread (DN8), <b>except in Europe where it is DN10</b>
Drain	3/4" (DN20) for models 25C and 100C 1" (DN25) for models 400C
Steam outlet	Varies with capacity and dispersion type. To determine outlet size, see DRI-CALC <sup>®</sup> or the "Maximum steam carrying capacity of interconnecting hose, tubing, or pipe" table in the DRI-STEEM Design Guide.
Condensate return	3/4" pipe thread (DN20)
Hot liquid supply inlet and return outlet	See dimensions tables.

**Table 7-2:  
LTS weights**

LTS model number	Shipping weight		Operating weight	
	lbs	kg	lbs	kg
25C	95	43	175	79
100C	105	48	350	158
400C	262	119	900	409

**Table 7-3:  
Properties of water 212 °F to 340 °F  
(100 °C to 171 °C) \***

Temperature		Pressure	
°F	°C	psia	kPa
212	100	14.7	101.3
220	104	17.2	118.4
230	110	20.8	143.2
240	116	25.0	172.0
250	121	29.8	205.5
260	127	35.4	244.1
270	132	41.9	288.4
280	138	49.2	339.0
290	143	57.6	396.6
300	149	67.0	461.7
310	154	77.7	535.2
320	160	89.7	617.8
330	166	103.1	710.1
340	171	118.0	813.1

**Note:**

\* Valves supplied by DRI-STEEM have a maximum inlet water temperature of 280 °F (138 °C).

---

## Selecting a location for the LTS

### Locating the humidifier

When selecting a location for the humidifier, consider the following:

- Maximum ambient temperature for the control cabinet is 104 °F (40 °C).
- Noises inherent to operation such as water fill cycles
- Easy access for maintenance
- Critical service and maintenance clearances around humidifier — primarily top, left side, and front (see clearance recommendations on next page)
- Convenient location to dispersion system for routing of vapor hose, tubing, or piping
- Electrical connections: Power, control, and safety circuits
- Piping connections: Hot liquid piping, condensate piping, and optional equipment
- Plumbing connections: Supply water, drain piping, and condensate return piping
- Water seal requirements
- Avoid locations above critical equipment or processes.
- Avoid locations close to sources of electromagnetic emissions such as power distribution transformers and high horsepower motors controlled by variable frequency drives.



# LTS clearance recommendations

**Figure 9-1:**  
**LTS clearance recommendations**

For recommended service and maintenance purposes, maintain the following clearances:

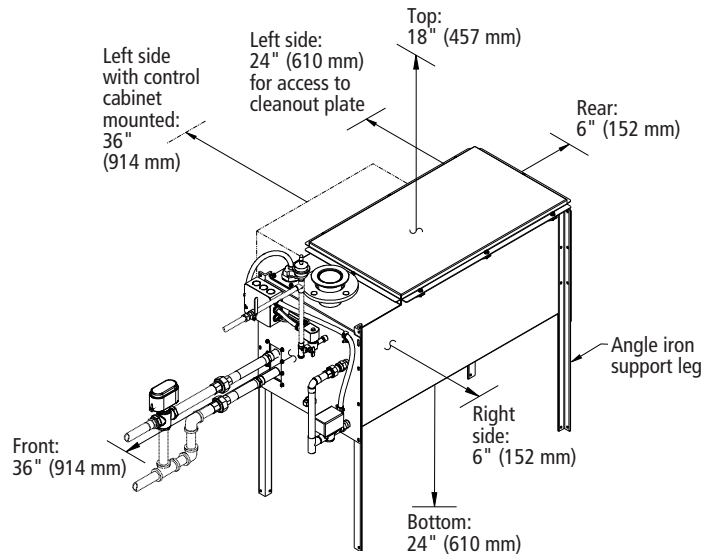

LTS-OM-04

## Mounting the LTS

**Table 10-1:  
Mounting options by model**

Mounting method	LTS/LTS-DI models			
	25C, 100C		400C	
	Standard	Optional	Standard	Optional
Trapeze	X			
H-legs			X	
Support legs		X		
Wall brackets		X		

**IMPORTANT:**

Installation must comply with governing codes.

### Mounting methods

To ensure that the water level control system works properly, the tank must be mounted level side to side and front to back.

For overhead installations, install a drip pan to prevent possible water damage.

Support legs, trapeze hanger, and wall brackets are not available for LTS/LTS-DI models 400. These models must use H-legs.

The mounting methods described in this manual are the only options available to maintain compliance to the UL 998 standard; alternate mounting methods will compromise the humidifier's CE, ETL, and C-ETL approvals.

## Mounting the LTS (continued)

### Trapeze hanger (LTS/LTS-DI models 25 and 100 only)

Secure threaded rod to an overhead structure that is strong enough to support the operating weight of the LTS/LTS-DI humidifier and field installed piping, plus the weight of the control cabinet if it is mounted on the humidifier.

Adjust the mounting so that the tank sets level side to side and front to back. Verify level after the tank is filled and is at operating weight.

**Figure 11-1:**  
Trapeze hanger (LTS models 25C and 100C only)

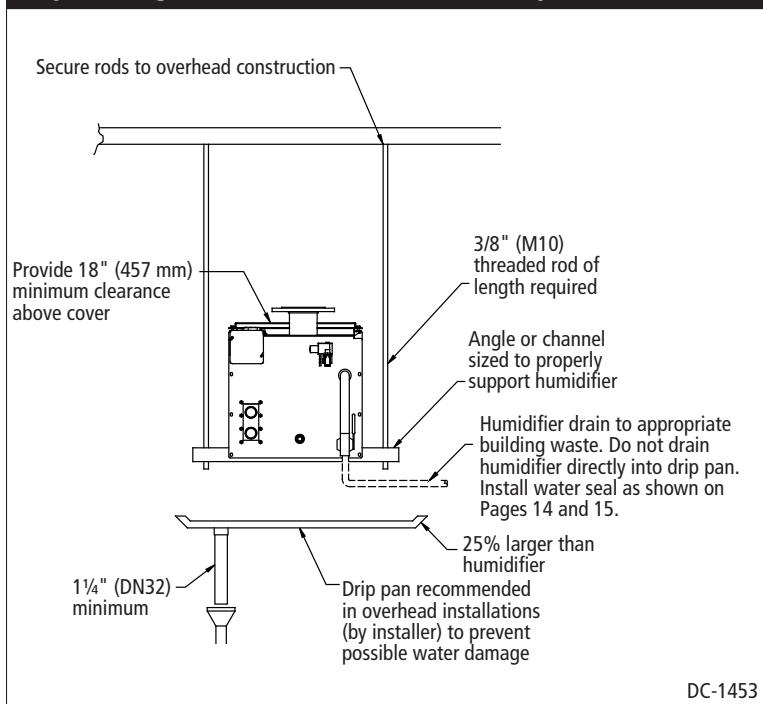

### Overhead installation

Do not install water piping and humidifiers above expensive apparatus or equipment. A broken water pipe, leaking valve gland, condensation or other water leaks can occur causing serious damage and costly repairs to the equipment below.

If this type of installation cannot be avoided, install a drip tray constructed of galvanized sheet metal under the humidifier, valve, etc., to catch potential water drips (see Figure 11-1).

Pipe the overflow from the LTS directly to a floor drain — do not drain the LTS into the drip pan. Terminate the drip pan and the LTS overflow drains above an open floor drain.

### IMPORTANT:

Installation must comply with governing codes.

## Mounting the LTS (continued)

**Figure 12-1:**  
**Support legs**  
**(LTS models 25C and 100C only)**

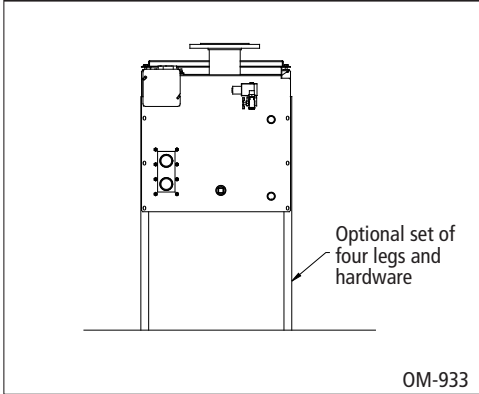

### Support legs (LTS/LTS-DI models 25 and 100 only)

Use enclosed bolts, nuts, and washers to fasten legs to tank. Shim or adjust so the tank sets level side to side and front to back. Verify level after the tank is filled and is at operating weight.

### H-legs (LTS/LTS-DI models 400 only)

While the LTS and LTS-DI tank is securely held in the air, attach front and rear supports using the supplied 3/8" (M10) bolts, nuts, and washers. **MAKE SURE THE BOTTOM OF THE TANK IS SUPPORTED BY THE H-LEG SUPPORTS.** This can be accomplished by having the bolts slightly loose as the tank is lowered to the floor. Then tighten them after the unit is placed.

Adjust the mounting so the tank sets level side to side and front to back. Verify the tank is level after it is filled and at operating weight.

**Figure 12-2:**  
**H-legs (required for LTS models 400C)**

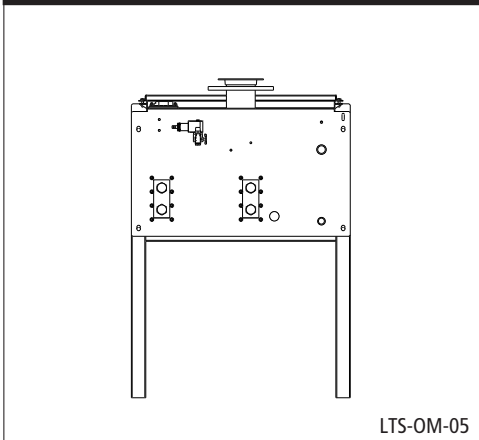

### IMPORTANT:

Installation must comply with governing codes.

## Mounting the LTS (continued)

### Wall brackets (LTS/LTS-DI models 25 and 100 only)

When mounting the LTS/LTS-DI with wall brackets, use 3/8" (M10) minimum fasteners as described below.

- **Mounting the LTS/LTS-DI on concrete or block walls:**
  - Position the wall brackets so that when fastened they will be flush with the inside of the front and back flanges of the LTS/LTS-DI tank.
  - Fasten the wall brackets with concrete anchors (expansion bolts) rated for the operating weight of the LTS/LTS-DI humidifier.
  - Fasten the LTS/LTS-DI tank securely to the wall brackets.
  - Shim or adjust so the tank sets level side to side and front to back. Verify level after the tank is filled and at operating weight.
- **Mounting Model LTS/LTS-DI 25 on a wood stud wall:**
  - Position two 2 × 4s (100 mm × 50 mm timbers) horizontally apart 24" (610 mm) on center (Dimension B in the table on this page).
  - Fasten these two horizontal 2 x 4s (timbers) with lag bolts (coach screws) to three vertical studs spaced 16" [404 mm] on center.
  - Position the wall brackets so that when fastened they will be flush with the inside of the front and back flanges of the LTS/LTS-DI tank, and fasten to the horizontal timbers.
  - Fasten the LTS/LTS-DI tank securely to the wall brackets.
  - Shim or adjust so the tank sets level side to side and front to back. Verify level after the tank is filled and at operating weight.
- **Mounting Model LTS/LTS-DI 100 on a wood stud wall:**
  - Position two 2 × 4s (100 mm × 50 mm timbers) horizontally apart 30" (610 mm) on center (Dimension B in the table on this page).
  - Fasten these two horizontal 2 x 4s (timbers) with lag bolts (coach screws) to four vertical studs spaced 16" [404 mm] on center.
  - Position the wall brackets so they are flush with the inside of the front and back flanges of the LTS/LTS-DI tank, and fasten to the horizontal timbers.
  - Fasten the LTS/LTS-DI tank securely to the wall brackets.
  - Shim or adjust so the tank sets level side to side and front to back. Verify level after the tank is filled and at operating weight.
- **Mounting the LTS/LTS-DI on metal stud walls:**
  - Follow wood stud mounting guidelines above and provide a second set of 2 × 4s (100 mm × 50 mm timbers) on the backside of the wall. Run a bolt with a washer through the face 2 × 4 (100 mm × 50 mm timber), the metal stud, and the backside 2 × 4 (100 mm × 50 mm timber) with washer and nut to connect the 2 × 4s (100 mm × 50 mm timbers).

### IMPORTANT:

Installation must comply with governing codes.

**Figure 13-1:  
Wall brackets  
(LTS models 25C and 100C only)**

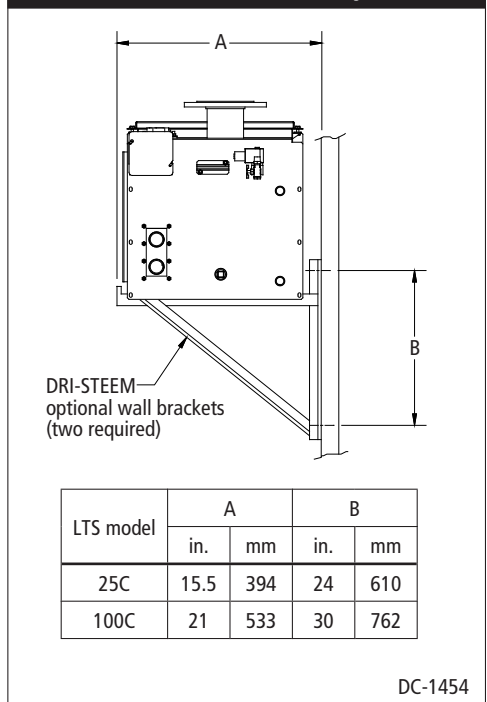

DC-1454

# LTS piping

**Figure 14-1:**  
**Field piping overview for LTS models 25C and 100C (models with one heat exchanger)**

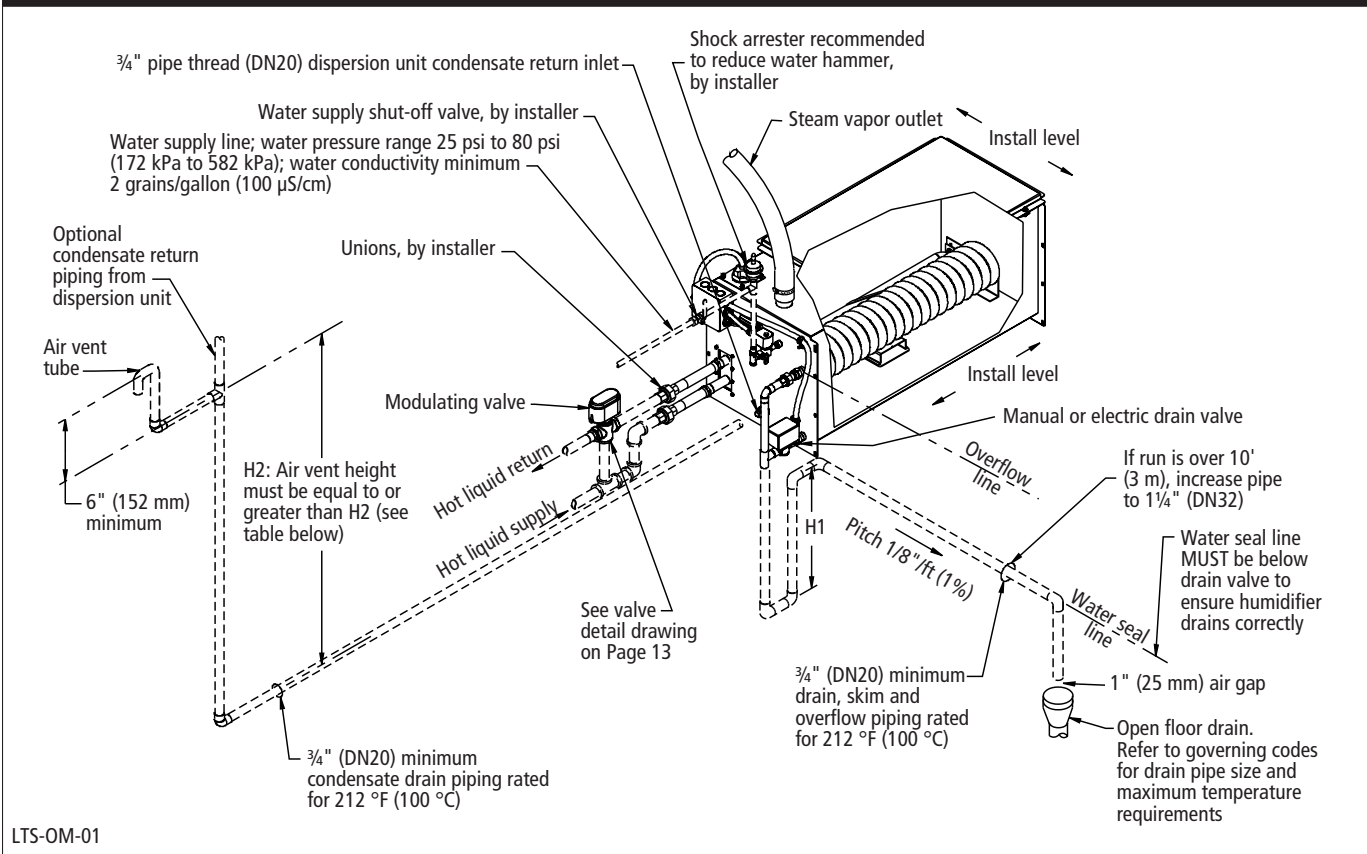

**Table 14-1:**  
**Heights required to overcome humidifier internal pressure (H1, H2)**

Unit output		Water seal height (H1)		Air vent height (H2)	
lbs/hr	kg/h	inches	mm	inches	mm
≤ 138	≤ 62	12	305	27	686
139–183	63–83	15	381	30	762
> 183	> 83	18	457	33	838

**Figure 14-1 notes:**

- The piping shown is for the standard three-way valve, normally closed to the heat exchanger. The three-way valve is recommended for constant system flow. If variable system flow is desired, a two-way valve located in the hot liquid return line is recommended.
- Offset humidifier from floor drain to prevent flash steam from rising into the humidifier.
- Dashed lines indicate provided by installer.
- The water supply inlet is more than 1" (25 mm) above the skim/overflow port, eliminating the possibility of backflow or siphoning from the tank. No additional backflow prevention is required; however, governing codes prevail.
- Install vent or petcock in hot liquid supply line to ensure removal of entrained air.
- Damage caused by chloride corrosion is not covered by your DRI-STEEM warranty.
- See the next page for recommended water supply piping for a DI/RO system or for piping a system with two heat exchangers.

# LTS piping (continued)

**Figure 15-1:**  
Field piping overview for LTS-DI 400C (DI model with two heat exchangers)

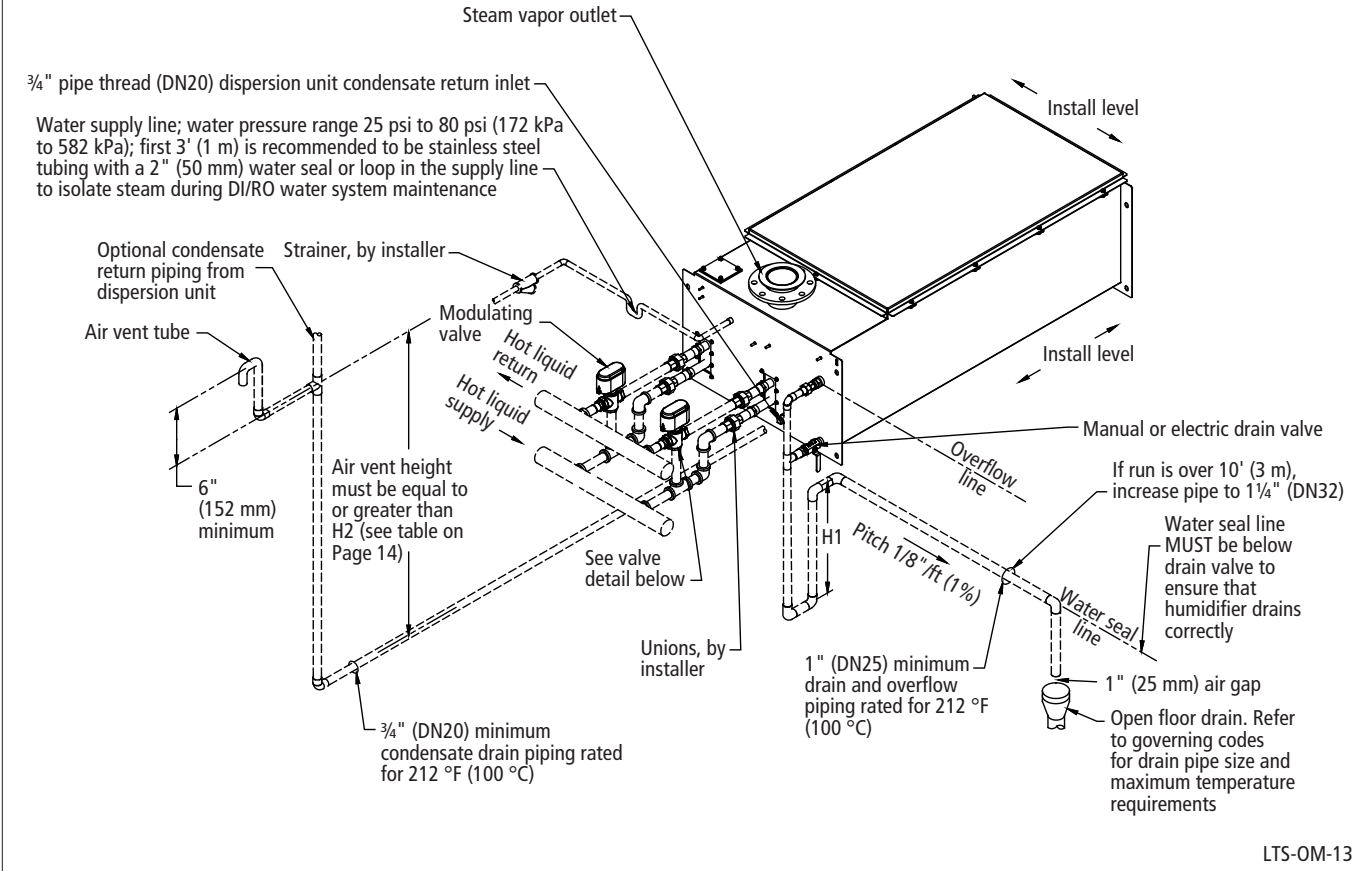

**Figure 15-1 notes:**

- The piping shown is for the standard three-way valve, normally closed to the heat exchanger. The three-way valve is recommended for constant system flow. If variable system flow is desired, a two-way valve located in the hot liquid return line is recommended.
- Offset humidifier from floor drain to prevent flash steam from rising into the humidifier.
- Dashed lines indicate provided by installer.
- The water supply inlet is more than 1" (25 mm) above the overflow port, eliminating the possibility of backflow or siphoning from the tank. No additional backflow prevention is required; however, governing codes prevail.
- Install vent or petcock in hot liquid supply line to ensure removal of entrained air.
- Damage caused by chloride corrosion is not covered by your DRI-STEEM warranty.
- See the previous page for recommended water supply piping for a standard water system or for piping a system with one heat exchanger.

**Figure 15-2:**  
Three-way valve detail

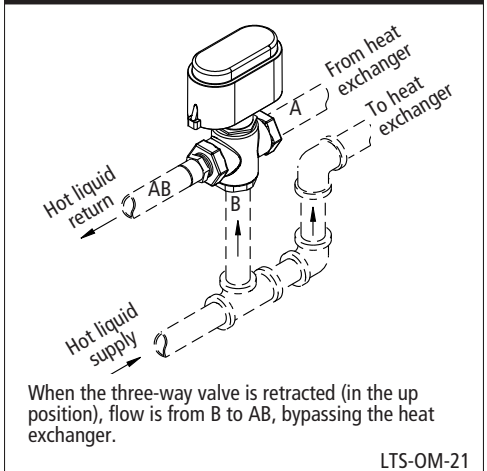

## LTS piping (continued)

**Figure 16-2:**  
**DRANE-KOOLER water tempering device**

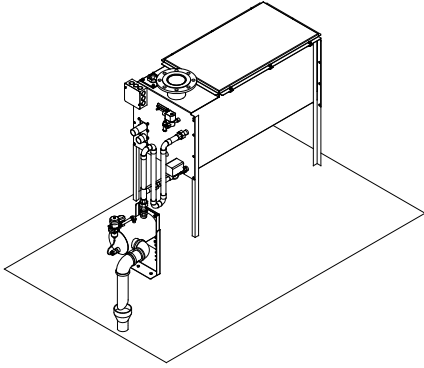

DRI-STEEM's DRANE-KOOLER, shown mounted to a typical humidifier, tempers discharged water temperature. For other DRANE-KOOLER mounting options or for more information, contact DRI-STEEM or view the DRANE-KOOLER product data sheet in the literature section at [www.dristeem.com](http://www.dristeem.com)

OM-951a

### Drain piping

The drain line piped from the humidifier must be run to an approved sanitary waste or suitable drain. If nonmetallic pipe or hose is used, it must be rated for 212 °F (100 °C) minimum continuous operating temperature.

Minimum drain pipe size is ¾" (DN20) inside diameter for models 25C and 100C, and 1" (DN25) for models 400. If the length of the drain piping exceeds 10' (3 m), increase the pipe size to 1¼" (DN32) pipe.

Do not locate the humidifier directly above a floor drain — skim and drain water dumped into the floor drain will cause flash steam. This steam will rise and saturate electrical components, adversely affecting component life and performance.

Governing codes may require that the 212 °F (100 °C) drain and skim water from the humidifier be tempered before it is discharged into the building drain piping. The DRANE-KOOLER™ option will temper 6 gpm (22.7 L/m) of 212 °F (100 °C) water to 140 °F (60 °C).

**To allow normal operation and prevent steam from escaping through the drain line, the installer must provide a water seal of a sufficient height to contain the pressure developed in the humidifier system.** See the table on Page 14 for water seal heights.

Drain piping after the water seal must be pitched a minimum of 1/8"/ft (1%) toward the drain. Governing codes may require more pitch.

If the proximity of a drain requires the humidifier drain and skim water to be lifted by a pump, DRI-STEEM offers a condensate pump option. A check valve is required on the discharge of the pump. Electrical power for the pump is independent of the humidifier. Plug the pump into a wall outlet; an integral float switch turns the pump on and off.



## LTS piping (continued)

### Drain piping (continued)

**LTS humidifier** — the drain connection to an LTS standard water humidifier is a pipe thread sweat (soldered) fitting. The installer should place a union directly after the factory drain fitting, provide a water seal of height H1 (from the table on Page 14), and pipe. To mount the humidifier closer to the floor, use the “Alternate water seal and drain valve piping” diagram shown on this page. The installer needs to rework the factory piping that connects the drain valve to the skim/overflow fitting, cut out the elbow, and repipe per the diagram.

The **LTS-DI humidifier** has a pipe thread fitting on the drain valve and on the overflow fitting. Prior to dumping into a drain, the installer needs to connect the drain and overflow, provide a water seal of height H1 (from the table on Page 14), and pipe. To mount the humidifier closer to the floor, use the “Alternate water seal and drain valve piping” diagram shown on this page.

### Alternate water seal and drain valve piping

Typically, the water seal height dictates the minimum dimension the bottom of the humidifier can be above the floor. The alternate water seal reduces the water seal piping below the humidifier up to 8" (203 mm), allowing the tank to sit closer to the floor.

**Figure 17-1:**  
**Alternate water seal and drain valve piping**

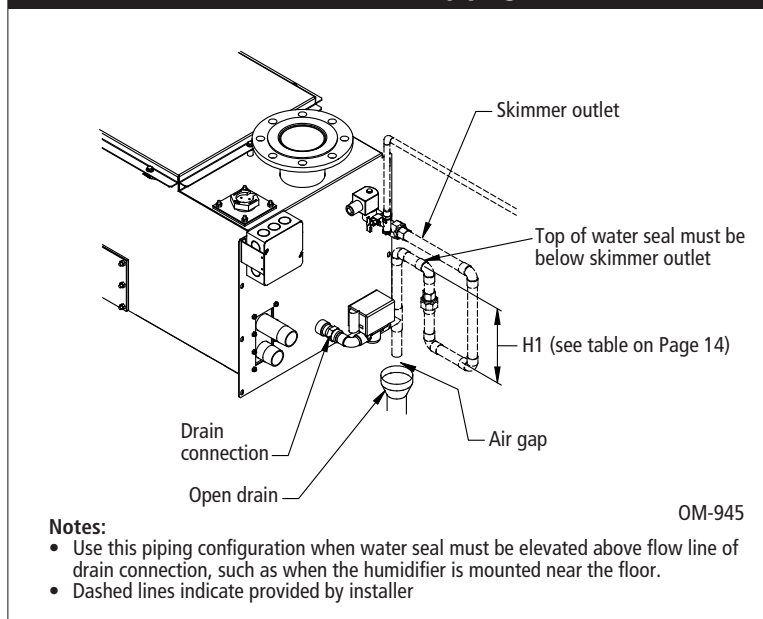

---

## LTS piping (continued)

### Water supply piping general instructions

The LTS and LTS-DI humidifiers have a 1" (25 mm) internal air gap to prevent back siphoning into a potable water system. However, some governing codes may require additional protection such as a vacuum breaker or backflow preventer.

The supply water pressure range must be 25 psi to 80 psi (172 kPa to 552 kPa) for all LTS and LTS-DI models.

### LTS model (standard water) water supply piping

The water supply assembly includes a strainer, needle valve, and fill solenoid, and has a ¼" pipe thread (DN8) connection. European models are provided with a 3/8" pipe thread (DN10) connection. Since the primary component of the water supply assembly is a solenoid valve, there may be noise issues that surface during a fill cycle.

During a fill cycle, the supply water drops the water temperature in the tank and may collapse the steam, which can cause a low rolling sound. To diminish this, adjust the needle valve to decrease the water fill rate and/or use hot supply water.

In cases where water hammer occurs when the fill solenoid closes, a shock arrester is recommended. Reducing the supply water pressure (minimum 25 psi [172 kPa]) or using flexible tubing (rated for 212 °F [100 °C] minimum continuous operating temperature) may diminish the noise, but installing a shock arrester is the best solution.

The minimum water conductivity for the LTS standard water model is 100 µS/cm (2 grains/gallon).

## LTS piping (continued)

### Water supply piping (continued)

#### LTS-DI model water supply piping

LTS-DI models control water level with a float valve, and have a ¼" pipe thread (DN8) connection. European models have a 3/8" pipe thread (DN10) connection. For DI models with the end-of-season drain option, a solenoid valve is added on the inlet of the float valve. The end-of-season feature shuts off the fill water supply and drains the tank when there is no demand for humidity for 72 hours. (This length of time is a default setting and is user-adjustable if your system has a VAPOR-LOGIC<sup>3</sup> controller. See the *VAPOR-LOGIC<sup>3</sup> Installation and Operation Manual* for more information.)

When using nonmetallic tubing for supply water, it must be rated for 212 °F (100 °C) minimum continuous operating temperature. DRI-STEEM recommends installing a three-foot (914 mm) piece of noninsulated stainless steel pipe directly off the humidifier prior to connecting to the nonmetallic tubing. When using nonmetallic tubing, DRI-STEEM recommends the installer place a 2" (50 mm) water seal/loop in the supply line to isolate steam during DI/RO water system maintenance.

DRI-STEEM recommends installing a strainer in the water supply line to prevent clogging of the float valve orifice. A strainer is highly recommended when the humidifier has the end-of-season drain option. The strainer will prevent particulate from collecting at the solenoid valve seat.

If the LTS-DI humidifier is supplied with tap water, the float valve assembly will become clogged and the humidifier will operate without water.

#### Note:

Damage caused by chloride corrosion is not covered by your DRI-STEEM warranty.

## LTS wiring

### CAUTION:

Only qualified electrical personnel should perform installation procedures.

### CAUTION:

When drilling holes in the control cabinet, make sure the unit is powered off, protect all internal components from debris, and vacuum out the control cabinet when finished. Failure to comply with this directive can damage sensitive electronic components and void your DRI-STEEM warranty.

### Where to find wiring diagrams

- Ladder style wiring diagrams (located inside the document package) show power, control, and humidifier to control cabinet interconnection requirements.
- External connections diagrams (located inside the document package) show connection points to the microprocessor-based controller and wire terminals for external safety and control devices: airflow proving switches, high limits, transmitters, or humidistats.

All wiring must be in accordance with all governing codes and with LTS wiring diagrams.

### Electrical installation

Wiring and branch circuit protection is provided by the installer per the National Electrical Code (NEC) or in Europe, IEC 60364. For power supply and machine ground connections, size the wire using the 75 °C wiring table, per the NEC (or IEC 60364). Then use copper conductors rated for a 105 °C environment. The wiring from the control cabinet to the humidifier must be rated for 105 °C.

LTS humidifiers have a 120-volt, single phase electrical supply except in Europe where it is 230-volt. Verify current characteristics and capacity requirements against those listed on the name plate.

### Wiring requirements

The length of wire from the control cabinet to the humidifier must not exceed 50' (15 m) when the controller is VAPOR-LOGIC3. When the controller is the LW417, the length of wire from the control cabinet to the humidifier must not exceed 30' (9 m).

The top portion of the control cabinet contains control circuitry; the bottom portion of the control cabinet contains power circuitry. Place conduit connection holes in the control cabinet so that the control and power wire routing is limited to their respective sides of the control cabinet.

Control wiring and power wiring must be run in dedicated or separated earthed metal conduit, cable trays, or trunking.

The control cabinet should be mounted in a location convenient for service with a minimum of 36" (914 mm) clearance in front of the door.

The installer is responsible for making electrical connections at the power terminals.

## LTS wiring (cont.)

### Control wiring

The following wiring methods for external low voltage control wiring should minimize electrical noise problems:

- Humidistat, RH transmitter, and temperature transmitter wiring must be minimum 18-gauge (1 mm<sup>2</sup>) plenum rated, shielded (screened), twisted pair wire with a bare drain wire for grounding.
- Airflow proving switch wiring must be minimum 18-gauge (1 mm<sup>2</sup>) stranded wire run in conduit. The airflow proving switch can be wired using minimum 18-gauge (1 mm<sup>2</sup>) plenum rated, shielded (screened), twisted pair wire with a bare drain wire for grounding.
- The shield (screen) wire should be connected to the shield (screen) ground terminal/lug with a length less than 2" (51 mm). Do not ground the shield (screen) wire on the humidistat or transmitter end.
- Water level control device, fill valve, and drain valve wiring must be minimum 18-gauge stranded wire run in a separate conduit from power wires. **DO NOT USE SHIELDED (SCREENED) CABLE FOR WATER LEVEL CONTROL DEVICES.**
- The tank temperature sensor can be run with 18-gauge (1 mm<sup>2</sup>) stranded wire if the control cabinet is located within 10' (3 m) of the humidifier. For wire lengths of 10' to 50' (3 m to 15 m), use 18-gauge (1 mm<sup>2</sup>) plenum rated, shielded (screened), twisted pair wire with a bare drain wire for grounding.

### CAUTION:

When drilling holes in the control cabinet, make sure the unit is powered off, protect all internal components from debris, and vacuum out the control cabinet when finished. Failure to comply with this directive can damage sensitive electronic components and void your DRI-STEEM warranty.

### IMPORTANT:

Do not use shielded (screened) cable for water level control devices.

## LTS wiring (cont.)

### IMPORTANT:

Failure to follow these wiring procedures can result in erratic operation or failure.

This product has been tested at the factory for proper operation. Product failures resulting from faulty handling, incorrect wiring, or shorting of wires together on external components are not covered under your DRI-STEEM warranty. Review information and diagrams before proceeding.

### Grounding requirements

The approved earth ground must be made with solid metal-to-metal connections and must be a good conductor of radio frequency interference (RFI) to earth (multistranded conductors).

Ground wire should be the same AWG (mm<sup>2</sup>) size as the power wiring or sized per NEC requirements (in Europe, IEC 60364 requirements).

When the control cabinet is mounted remotely from the humidifier, a ground wire is necessary from the machine ground lug on the humidifier to the machine ground lug in the control cabinet. The bonding machine ground wire should be no less than 14-gauge AWG (mm<sup>2</sup>) or sized per NEC or IEC 60364 requirements.

**Figure 22-1:**  
**Humidifiers with VAPOR-LOGIC<sub>3</sub> control**

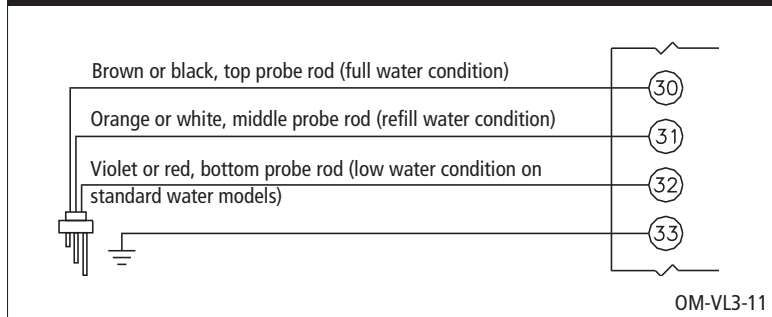

**Figure 22-2:**  
**Humidifiers with LW417 control**

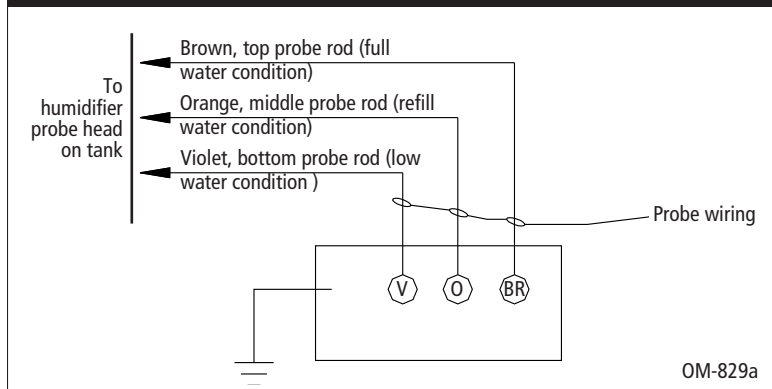

---

## Dispersion: General instructions

### Selecting the dispersion assembly location

- It is important that the dispersion assembly be positioned where the water vapor being discharged is carried off with the airstream and does not cause condensation or dripping from the duct.
- In general, the dispersion assembly is best placed where the air can most readily absorb the moisture being added without causing condensation at or after the unit. This normally will be after the heating coil or where the air temperature is highest.
- Do not place the dispersion assembly too close to the intake of a high efficiency filter. The filter can remove the visible moisture and become waterlogged.
- Do not place the dispersion assembly where water vapor will impinge on a metal surface.
- Do not place the dispersion assembly where water vapor will impinge on fire or smoke detection devices.
- Do not place the dispersion assembly too close to a split in the duct. The unit can put more moisture in one branch than the other.
- For more information about dispersion assembly placement, see DRI-STEEM's *Humidification System Design Guide* available at [www.dristeem.com](http://www.dristeem.com) or by calling 800-328-4447.

### Where to find specific installation instructions by product

- For all dispersion assemblies, read Pages 24-26 for information about interconnecting piping and drip tee installation
- For ULTRA-SORB installation instructions, see the *ULTRA-SORB Installation, Operation and Maintenance* manual.
- For Single Tube and Multiple Tube installation instructions, see Pages 27-30.
- For RAPID-SORB installation instructions, see Pages 31-37.

### Note:

Most DRI-STEEM literature is available for downloading and printing from our website, [www.dristeem.com](http://www.dristeem.com)

## Dispersion: Interconnecting piping requirements

### IMPORTANT:

Failure to follow the recommendations in this section can result in excessive back pressures on the humidifier. This will result in unacceptable humidification system performance such as leaking gaskets, blown water seals, erratic water level control, and spitting condensate from the dispersion tube(s).

### Connecting humidifier to dispersion assembly with vapor hose

- Always support vapor hose to prevent sags or low spots and to maintain a minimum pitch of 2"/ft (15%) back to the humidifier.
- See the maximum steam carrying capacity table on the next page.
- Use DRI-STEEM vapor hose. Other manufacturers of vapor hose may use unacceptable release agents or material mixes that can affect humidifier system performance adversely. Using hose from alternative manufacturers increases the possibility of tank foaming and accelerated aging. Foaming causes condensate discharge at the dispersion assembly.
- Do not use vapor hose in outdoor applications.
- Do not insulate vapor hose. Insulation causes accelerated heat aging, causing the vapor hose to become hard and susceptible to failure due to cracks.
- The steam outlet on the humidifier is sized to the output of the humidifier. DO NOT use hose with an inside diameter (ID) smaller than the humidifier steam outlet.
- If the humidifier must be located above the dispersion assembly, use the recommend installation as shown on Page 26.
- For Single Tube applications, see the hose kit sizing chart on Page 27.

### Connecting humidifier to dispersion assembly with tubing or pipe

- The steam outlet on the humidifier is sized to the output of the humidifier. DO NOT use interconnecting tubing or pipe with an inside diameter (ID) smaller than the humidifier steam outlet. REDUCING THE INSIDE DIAMETER OF THE INTERCONNECTING PIPING WILL RESULT IN THE INTERNAL HUMIDIFIER SYSTEM PRESSURE EXCEEDING THE PARAMETERS FOR ACCEPTABLE PERFORMANCE.
- Steam supply adapters are available from DRI-STEEM. These adapters convert a tubing outlet on the humidifier to threaded pipe, allowing a pipe connection.
- 90° elbows are not recommended; use two 45° elbows, 1' (0.3 m) apart.
- Thin wall tubing heats up faster and causes less start-up loss than heavy wall pipe.

More on the next page ►



## Dispersion: Interconnecting piping requirements (continued)

### Connecting humidifier to dispersion assembly with tubing or pipe (continued)

- Insulating hard pipe reduces the loss in output caused by condensation.
- When using hard pipe, take care to remove ALL traces of lubricants used to thread the pipe. This will minimize the possibility of tank foaming. Denatured alcohol or mineral spirits work best for removing lubricant.
- If the humidifier must be located above the dispersion assembly, use the recommend installation as shown on Page 26.
- See the maximum steam carrying capacity table below.

**Table 25-1:  
Maximum steam carrying capacity and length of interconnecting vapor hose, tubing, and pipe\***

Vapor hose <sup>†††</sup>						Copper or stainless steel tubing and Schedule 40 steel pipe					
Hose I.D.		Maximum capacity		Maximum length <sup>**</sup>		Tube or pipe size <sup>***</sup>		Maximum capacity		Maximum developed length <sup>†</sup>	
inches	DN	lbs/hr	kg/h	ft	m	inches	DN	lbs/hr	kg/h	ft	m
1½	40	150	68	10	3	1½	40	150	68	20	6
2	50	250	113	10	3	2	50	220	100	30	9
						3 <sup>††</sup>	80 <sup>††</sup>	450	204	80	24
						4 <sup>††</sup>	100 <sup>††</sup>	750	340	100	30
						5 <sup>††</sup>	125 <sup>††</sup>	1400	635	100	30
						6 <sup>††</sup>	150 <sup>††</sup>	2300	1043	100	30

\* Based on total maximum pressure drop in hose, tubing, or pipe of 5" wc (1244 Pa)

\*\* Maximum recommended length for vapor hose is 10' (3 m). Longer distances can cause kinking or low spots.

\*\*\* To minimize loss of capacity and efficiency, insulate tubing and pipe.

† Developed length equals measured length plus 50% of measured length to account for pipe fittings.

†† Requires flange connection

††† When using vapor hose, use DRI-STEEM vapor hose for best results. Field-supplied hose may have shorter life and may cause foaming in the evaporating chamber resulting in condensate discharge at the dispersion assembly. Do not use vapor hose for outdoor applications.

## Dispersion: Drip tee installation

Install a drip tee as show below when the humidifier is mounted higher than the dispersion assembly, when interconnecting hose or piping needs to go over an obstruction, or when interconnecting piping runs are long.

**IMPORTANT:** Vapor hose must be supported to prevent sagging or low spots.

**Figure 26-1:**  
Drip tee installation (piping over an obstruction)

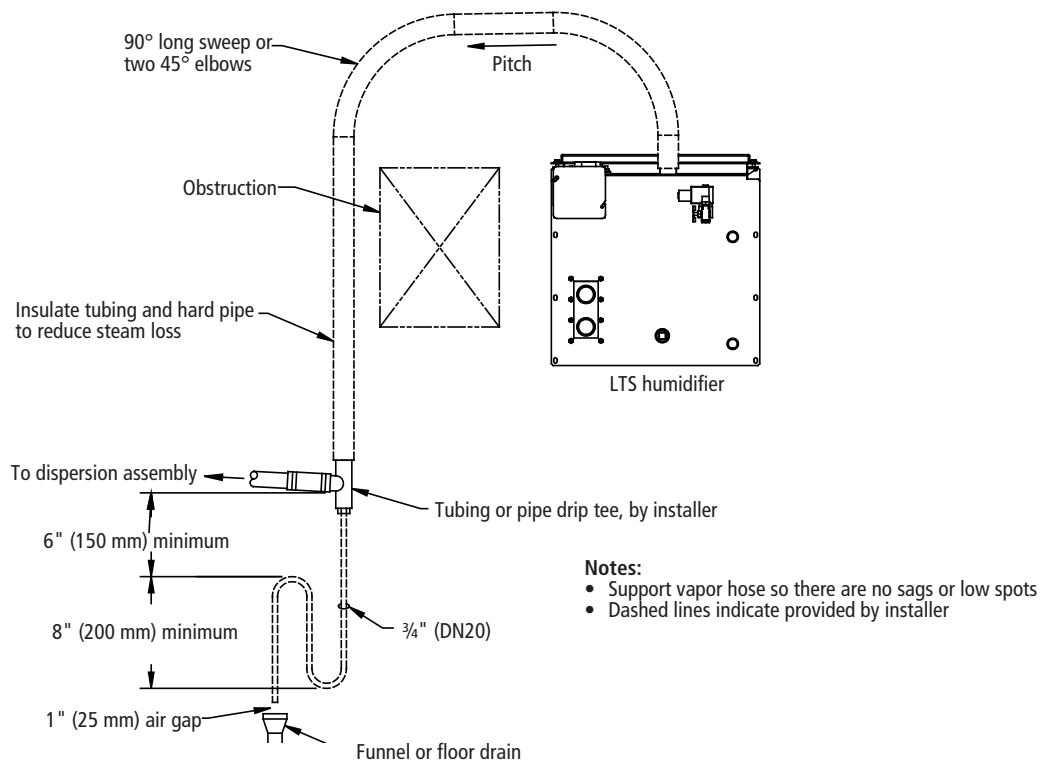

DC-1470

# Dispersion: Single Tube and Multiple Tube

## Installation

- See the following pages for detailed drawings and notes for installing Single Tube and Multiple Tube dispersion assemblies
- See the hose kit sizing table on this page for Single Tube applications

## Dispersion tube mounting

- Orient dispersion tube(s) so that tubelets (steam orifices) point up.
- See the table on this page for dispersion tube pitch requirements.
- When mounting the humidifier above the level of the dispersion tube(s), see the drip tee installation drawing on Page 24.

## Condensate drain piping

- Minimum diameter (ID) for draining from one or two dispersion tubes: ¾" (DN20)
- Minimum diameter (ID) for draining from three or more dispersion tubes: 1" (DN25)

## IMPORTANT:

Failure to follow the recommendations in this section can result in excessive back pressures on the humidifier. This will result in unacceptable humidification system performance such as leaking gaskets, blown water seals, erratic water level control, and spitting condensate from the dispersion tube(s).

Table 27-1: Hose kit sizing by capacity		
Maximum humidifier capacity		Hose kit
lbs/hr	kg/h	
56.8	25.8	1½" (DN40) with drain
85.2	38.6	2" (DN50) with drain
> 85.2	>38.6	These models require multiple tube assemblies and cannot use a hose kit.

**Table 27-2:  
Pitch of dispersion tube(s) and interconnecting piping for Single Tube or Multiple Tube evaporative dispersion units\***

Condensate drain	Type of interconnecting piping	Diameter of dispersion tube and interconnecting piping	Pitch of interconnecting piping	Pitch of dispersion tube(s)	Pitch of condensate drain
Without drain	Vapor hose	1½" (DN40)	2"/ft (15%) toward humidifier	2"/ft (15%) toward humidifier	No drain
		2" (DN50)			
	Tubing or pipe	1½" (DN40)	1/8"/ft (1%) toward humidifier		
		2" (DN50)			
With drain	Vapor hose	1½" (DN40)	2"/ft (15%) toward humidifier	1/8"/ft (1%) toward condensate drain	¼"/ft (2%) toward floor drain or toward humidifier if humidifier is below dispersion unit
		2" (DN50)			
	Tubing or pipe	1½" (DN40)	½"/ft (5%) toward humidifier		
		2" (DN50)			

**Note:**  
When piping over an obstruction, see the drip tee installation illustration on the previous page.

# Dispersion: Single Tube and Multiple Tube (continued)

**Figure 28-1:**  
Single Tube dispersion with condensate wasted to floor drain

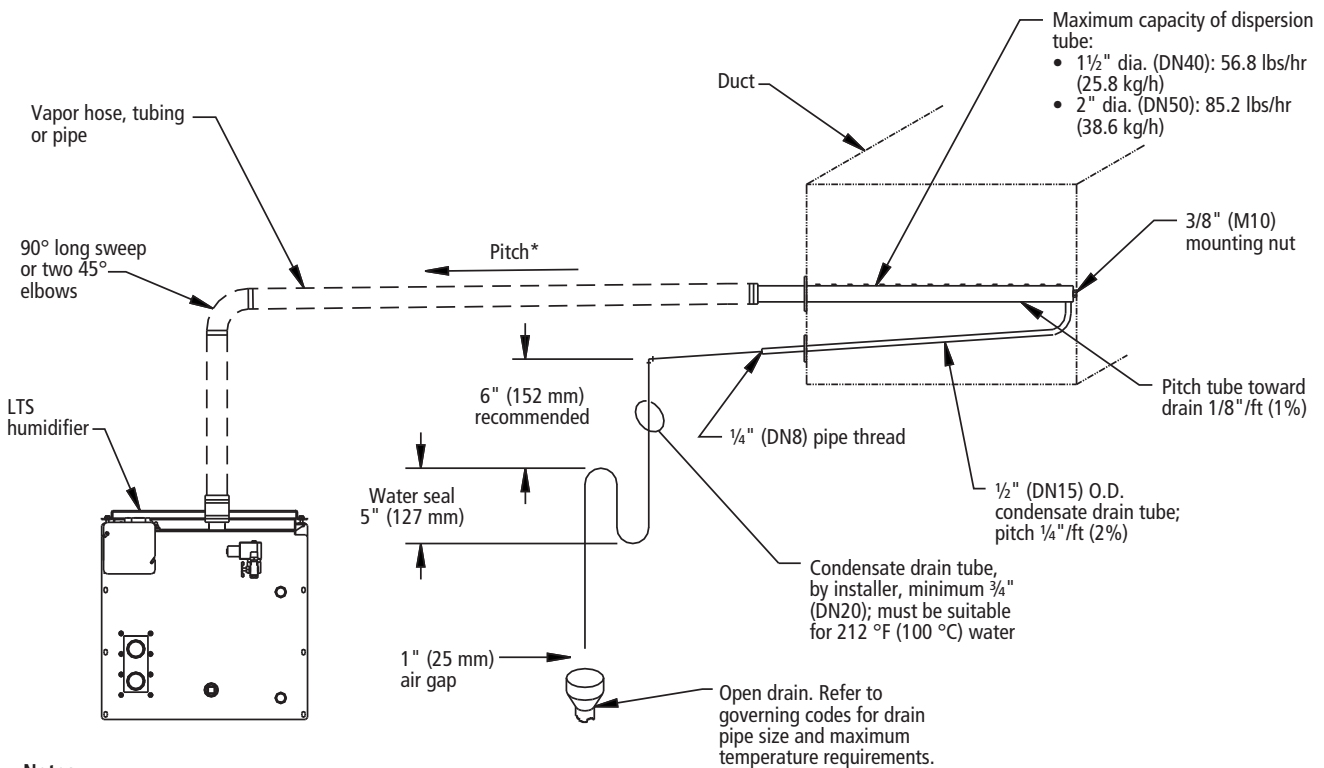

**Notes:**

- \* Pitch vapor hose, tubing or pipe toward humidifier:
  - 2"/ft (15%) when using vapor hose
  - 1/2"/ft (5%) when using 1 1/2" tubing or pipe
  - 1/4"/ft (2%) when using 2" tubing or pipe
- Dashed lines indicate provided by installer

DC-1473a

**Figure 28-2:**  
Dispersion tube escutcheon plates

**Dispersion tube plate**

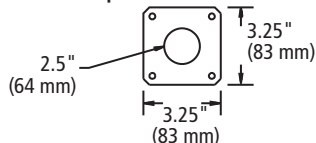

**Condensate drain plate**

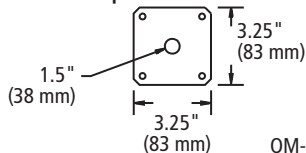

OM-351c

**Figure 28-3:**  
Single Tube dispersion with condensate drain

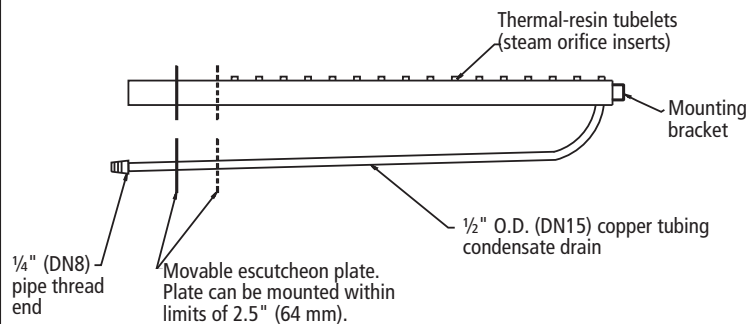

OM-351b

# Dispersion: Single Tube and Multiple Tube (continued)

**Figure 29-1:  
Single Tube with condensate returned to humidifier**

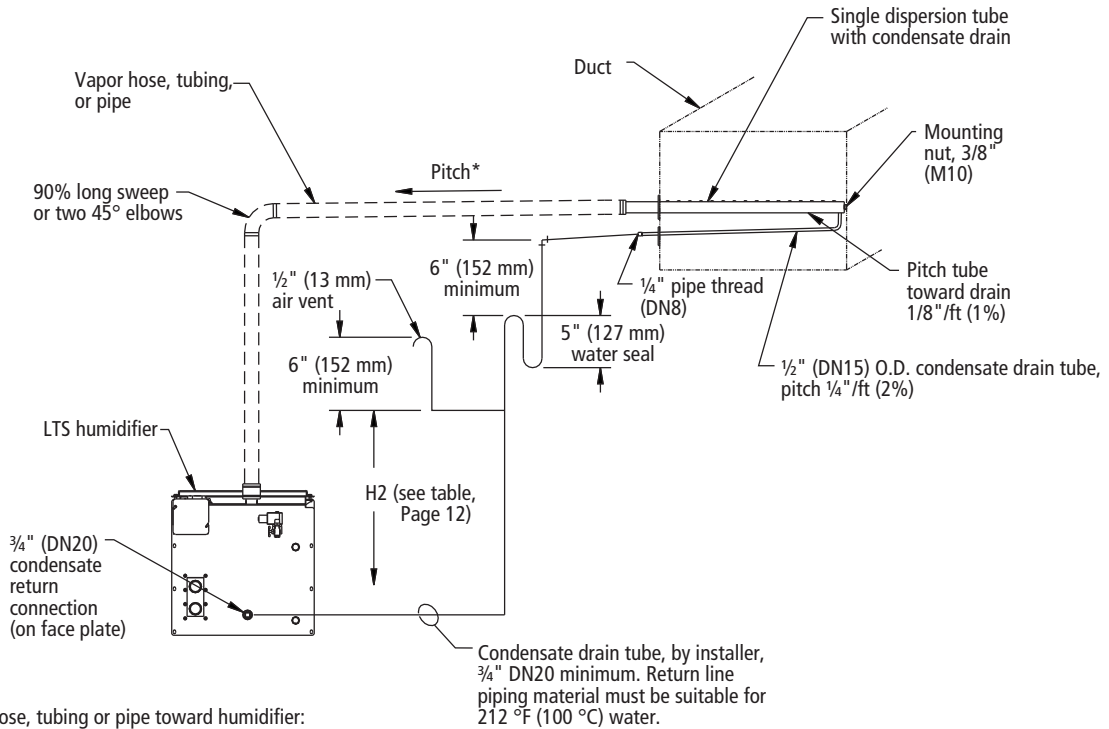

**Notes:**

- \* Pitch vapor hose, tubing or pipe toward humidifier:
  - 2"/ft (15%) when using vapor hose
  - 1/2"/ft (5%) when using 1 1/2" tubing or pipe
  - 1/4"/ft (2%) when using 2" tubing or pipe
- Dashed lines indicate provided by installer

Condensate drain tube, by installer, 3/4" DN20 minimum. Return line piping material must be suitable for 212 °F (100 °C) water.

DC-1473b

## Dispersion: Single Tube and Multiple Tube (continued)

**Figure 30-1:  
Multiple Tube with condensate wasted to floor**

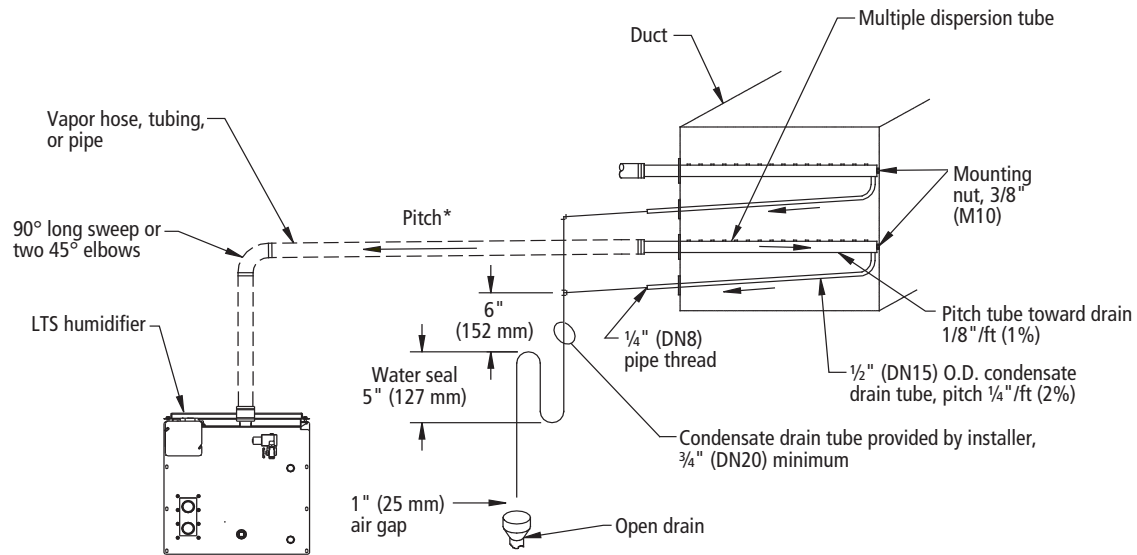

**Notes:**

- \* Pitch vapor hose, tubing or pipe toward humidifier:
  - 2" /ft (15%) when using vapor hose
  - 1/2" /ft (5%) when using 1 1/2" tubing or pipe
  - 1/4" /ft (2%) when using 2" tubing or pipe
- Dashed lines indicate provided by installer

DC-1048a

## Dispersion: RAPID-SORB

### General RAPID-SORB installation instructions

- Before you begin installation, read all dispersion instructions in this manual.
- Before you begin installation, unpack shipment and verify receipt of all RAPID-SORB components with packing list. Report any shortages to DRI-STEEM factory immediately.
- When choosing a location for installation, select a location that provides necessary access in and around the ductwork or air handler.
- The RAPID-SORB typically is installed centered side to side in a duct, or is installed across the face of a coil in an air handler.
- The center line of the outer dispersion tubes should never be closer than 4.5" (114 mm) from the side of the ductwork or air handler wall.
- RAPID-SORBs are provided with an L-bracket for installation:
  - L-brackets that are 50" (1270 mm) or less in length have a hole 4" (102 mm) in from each end to mount the L-bracket to the duct or air handler wall.
  - L-brackets that are greater than 50" (1270 mm) in length have an additional hole in the center of the L-bracket.
  - **IMPORTANT:** Before marking and drilling holes in the duct or air handler, refer to ALL pitch requirements for the RAPID-SORB assembly you received (see the table on Page 32). The size, quantity, and location of penetrations are determined by the specific dimensions and configuration of the RAPID-SORB assembly you received.
  - **Note:** The hardware for mounting the L-bracket to the duct or air handler wall and the hardware for the header support bracket is not provided.
- The RAPID-SORB instructions that follow are for the most typical RAPID-SORB installations — installed in a duct horizontal airflow with RAPID-SORB header either inside or outside the duct. Contact your representative/distributor or DRI-STEEM for installation instructions for air handler or vertical airflow applications.

### IMPORTANT:

Failure to follow the recommendations in this section can result in excessive back pressures on the humidifier. This will result in unacceptable humidification system performance such as leaking gaskets, blown water seals, erratic water level control, and spitting condensate from the dispersion tube(s).

## Dispersion: RAPID-SORB (continued)

**IMPORTANT:**

Failure to follow the recommendations in this section can result in excessive back pressures on the humidifier. This will result in unacceptable humidification system performance such as leaking gaskets, blown water seals, erratic water level control, and spitting condensate from the dispersion tube(s).

**RAPID-SORB pitch requirements**

- When installing RAPID-SORB with the header outside a horizontal airflow duct, consider the following pitch issues:
  - For 1½" (DN40) dispersion tubes, use a fastener of sufficient length to accommodate the 1/8"/ft (1%) pitch requirements toward the ¾" pipe thread (DN20) header drain fitting.
  - For 2" (DN50) dispersion tubes, the bracket can be mounted flush to the ductwork. The 1/8"/ft (1%) pitch typically can be accomplished in the length of the hose cuffs used to connect the tubes to the header.
- See the table below and the drawings on the following pages for pitch requirements.

**Table 32-1:  
Pitch of interconnecting piping, dispersion tubes, and headers for RAPID-SORB evaporative dispersion units**

Airflow	Type of interconnecting piping	Diameter of interconnecting piping	Pitch of interconnecting piping	Pitch of dispersion tubes	Pitch of header
Horizontal	Vapor hose	1½" (DN40), 2" (DN50)	2"/ft (15%) toward RAPID-SORB	Vertically plumb	1/8"/ft (1%) toward condensate drain
	Tubing or pipe	1½" (DN40), 2" (DN50), 3" (DN80), 4" (DN100), 5" (DN125), 6" (DN150)	1/8"/ft (1%) toward RAPID-SORB		
Vertical	Vapor hose	1½" (DN40), 2" (DN50)	2"/ft (15%) toward RAPID-SORB	2"/ft toward header	1/8"/ft (1%) toward condensate drain
	Tubing or pipe	1½" (DN40), 2" (DN50), 3" (DN80), 4" (DN100), 5" (DN125), 6" (DN150)	1/8"/ft (1%) toward RAPID-SORB		



## Dispersion: RAPID-SORB (continued)

**Figure 33-1:**  
**RAPID-SORB installed in a horizontal airflow with header outside the duct**

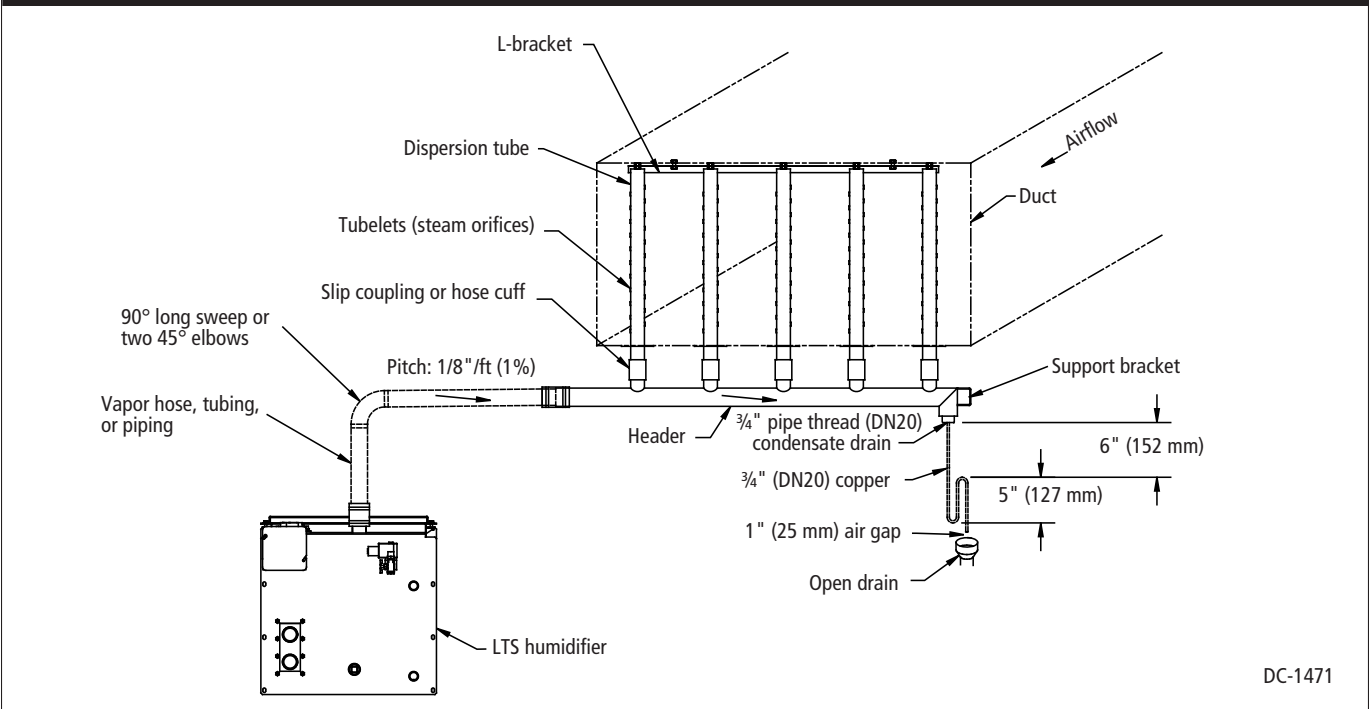

DC-1471

### Assembly and installation instructions for a RAPID-SORB installed with header outside the duct (horizontal airflow)

1. Locate and cut the holes in the ductwork for the dispersion tubes. Use the L-bracket as a template to locate the holes on the duct floor.
2. Temporarily, loosely suspend or support the header below the final location — the vertical balance point of the dispersion tube length dictates where the header should be suspended or supported temporarily.
3. Mount the dispersion tubes to the header with the provided connector, either a slip coupling or a hose cuff.
  - When installing slip couplings for 1½" (DN40) dispersion tubes, take care not to shear the O-rings.
  - Set the slip coupling on the header stub or dispersion tube so the O-ring is resting on the face of the tubing.
  - Rotate the slip coupling as you push it on to the tubing.
  - The O-rings are lubricated at the factory. If additional lubrication is necessary, DO NOT use a petroleum-based lubricant.
4. Position the flange of the L-bracket so it is upstream of the tubes when the assembly is raised and fastened into position. Fasten the

## Dispersion: RAPID-SORB (continued)

### Note:

See Page 37 for steam supply and condensate drain line connection instructions.

### Assembly and installation instructions for a RAPID-SORB installed with header outside the duct (continued)

L-bracket to the end of the dispersion tubes with the provided bolt, lock washer, and flat washer.

5. Before tightening the L-bracket bolts to the dispersion tubes follow these instructions:
  - For 1½" (DN40) dispersion tubes:
    - The dispersion tube will rotate in the slip coupling. Verify that the dispersion tube orifices are directed perpendicular to the airflow.
    - The dispersion tube and slip coupling must be fully engaged on to the header stub for the O-rings to provide a seal.
  - For 2" (DN50) dispersion tubes:
    - Before securing the hose cuff in place with the hose clamps on the dispersion tube and the header stub, verify that the dispersion tube orifices are directed perpendicular to the airflow.
6. Slide the assembly up until the L-bracket aligns with the mounting holes in the duct.
  - For 1½" (DN40) dispersion tubes:
    - The header pitch is duplicated in the L-bracket.
    - The dispersion tube and slip coupling must be fully engaged on to the header stub for the O-rings to provide a seal.
    - The high end of the L-bracket can be fastened tight to the duct or air handler.
    - On the low end of the L-bracket, the fastener must be long enough to compensate for the pitch, and a nut should be provided and secured on both sides of the L-bracket and the duct or air handler for stability.
  - For 2" (DN50) dispersion tubes:
    - Fasten the bracket to the top of the duct and use the hose cuffs to compensate for the pitch of the header.
    - Before securing the hose cuff in place with the hose clamps on the dispersion tube and the header stub, verify that the header pitch, 1/8"/ft (1%) toward drain, is maintained.
7. Permanently secure both ends of the header and verify that the header pitch, 1/8"/ft (1%) toward drain, is maintained.
8. Verify that all fasteners are secure:
  - L-bracket to duct
  - Dispersion tubes to L-bracket
  - Hose clamps on 2" (DN50) tubes
9. Secure and seal the dispersion tube escutcheon plate and condensate drain tube escutcheon plate around the respective tubes, if applicable.

## Dispersion: RAPID-SORB (continued)

**Figure 35-1:**  
**RAPID-SORB installed in a horizontal airflow with header inside the duct**

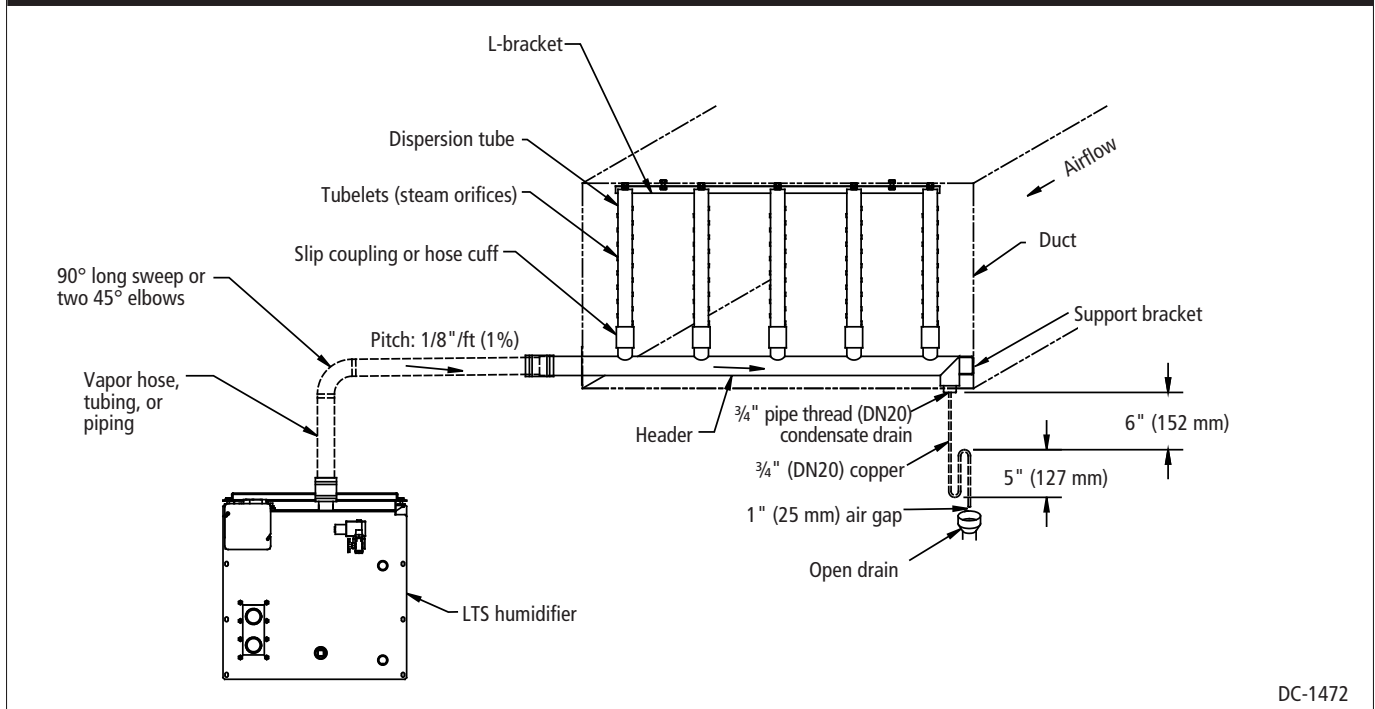

DC-1472

### Assembly and installation instructions for a RAPID-SORB installed with header inside the duct (horizontal airflow)

1. Locate and cut the holes in ductwork or air handler for steam header penetration, condensate drain piping, and header support bracket fastener. Allow 1/8"/ft (1%) header pitch toward the support bracket when you drill the hole for the header support bracket fastener.
2. Loosely fasten the header in place.
3. Rotate the header 90° so the header stubs point horizontally in the duct.
  - When installing in an air handler, the rotation of the header is often less than 90°. Typically, due to the condensate drain piping requirements, the header can be set on the floor of the air handler, assembled in the vertical position, and then raised and mounted in place.
4. Mount the dispersion tubes on the header with the slip couplings or hose cuffs.
  - When installing slip couplings for 1½" (DN40) dispersion tubes, take care not to shear the O-rings.
  - Set the slip coupling on the header stub or dispersion tube so the O-ring is resting on the face of the tubing.

## Dispersion: RAPID-SORB (continued)

### Assembly and installation instructions for a RAPID-SORB installed with header inside the duct (continued)

- Rotate the slip coupling as you push it on to the tubing.
  - The O-rings are lubricated at the factory. If additional lubrication is necessary, DO NOT use a petroleum-based lubricant.
5. Allow the dispersion tubes to rest against the bottom of the duct.
  6. Position the flange of the L-bracket so it is upstream of the tubes when the assembly is rotated into position. Fasten the L-bracket to the end of the dispersion tubes with the provided bolt, lock washer, and flat washer.
  7. Rotate the assembly up until the L-bracket aligns with the mounting holes in the duct or air handler.
    - 1½" (DN40) dispersion tubes
      - The header pitch is duplicated in the L-bracket.
      - The dispersion tube and slip coupling must be fully engaged on to the header stub for the O-rings to provide a seal.
      - The high end of the L-bracket can be fastened tight to the duct or air handler.
      - On the low end of the L-bracket, the fastener must be long enough to compensate for the pitch, and a nut should be provided and secured on both sides of the L-bracket and the duct or air handler for stability.
    - 2" (DN50) dispersion tubes
      - Fasten the bracket to the top of the duct or air handler and use the hose cuffs to compensate for the pitch of the header.
      - Before securing the hose cuff in place, with the hose clamps on the dispersion tube and the header stub, verify that the dispersion tube orifices are directed perpendicular to the airflow.
  8. Verify that all fasteners are secure:
    - L-bracket to duct
    - Dispersion tubes to L-bracket
    - Hose clamps on 2" (DN50) tubes
    - Header support bracket fastener
  9. Secure and seal the header escutcheon plate around the header.
  10. See Page 35 for steam supply and condensate drain line connection instructions.

---

## Dispersion: RAPID-SORB (continued)

### Steam supply connections to the RAPID-SORB header

1. Connect the steam supply of the humidifier to the RAPID-SORB. The steam supply requires a minimum of 1/8"/ft (1%) pitch toward the header.
2. If multiple humidifiers are supplying one RAPID-SORB, a multiple steam supply connector is provided.
  - Typically, the multiple steam supply connector attaches to the RAPID-SORB header supply end with hose cuff and clamps.
  - Route the necessary number of steam supplies from the humidifier tanks to the steam supply connector.
  - Position the steam supply connector to accept the steam supplies while maintaining the necessary pitch.
  - Make sure the hose clamps on the steam supply connector and header are tight.

### Condensate drain connections to the RAPID-SORB header

1. Piping must be minimum ¾" I.D. (DN20) and rated for 212 °F (100 °C) minimum continuous operating temperature.
2. Condensate drain line must be piped as shown in the figures on the previous pages. Provide a 6" (152 mm) drop prior to a 5" (127 mm) water seal to:
  - Ensure drainage of condensate from the header
  - Keep steam from blowing out of the drain line
3. After the water seal, run the drain line to an open drain with a 1" (25 mm) vertical air gap. Cut the drain line at a 45° angle on the end above the drain to permit a direct stream of water into the drain pipe while maintaining a 1" (25 mm) air gap.
4. All drain lines must be installed and sized according to governing codes.

## Start-up procedures

### CAUTION:

Only qualified electrical personnel should perform the start-up procedure.

### IMPORTANT:

For LTS models with VAPOR-LOGIC<sub>3</sub> control (those models that have a keypad), see also the *VAPOR-LOGIC<sub>3</sub> Installation and Operation Manual*, specifically the "Operation" section and the "Start-up checklist." It is critical that the installer follow this checklist.

After the system is installed and connected properly, you can begin start-up procedures.

1. Verify that the LTS humidifier, controls, piping, electrical connections, steam supply, and dispersion unit(s) are installed according to the following:
  - Installation instructions in this manual
  - *VAPOR-LOGIC<sub>3</sub> Installation and Operation Manual*
    - Installation section
    - Installation checklist
  - LW417 wiring instructions in this manual (if using LW417 water level control).
  - Ladder style wiring diagram (inside control cabinet)
  - External connections wiring diagram (inside control cabinet)
  - All governing codes
2. Verify that the humidifier is mounted level and securely supported before filling with water (see the operating weights table in this manual).
3. Verify that the humidifier is level front to back and side to side after it is full of water.
4. Refer to your humidifier's controller instructions. A standard water LTS system has either VAPOR-LOGIC<sub>3</sub> control (has a keypad) or the LW417 controller (no keypad). Refer to the *VAPOR-LOGIC<sub>3</sub> Installation and Operation Manual*, specifically the "Operation" section and the "Start-up checklist" (it is critical that the installer follow this checklist), or see the LW417 section of this manual.
5. During start-up, do not leave the humidifier unattended.
6. Monitor humidifier operation through multiple fill cycles.
7. DRI-STEEM recommends initially running the humidifier with the factory default setting for skim time. (See the "LTS and LTS-DI operation information" section in this manual.)
8. On standard water units, water skims from the humidifier after every fill cycle. Adjust the amount of skim by increasing or decreasing the skim time (see the *VAPOR-LOGIC<sub>3</sub> Installation and Operation Manual* or the LW417 "Skim duration" section in this manual).

## Start-up: LW417 control

### LW417: Water level control for standard-water models

The LW417 is a custom microprocessor-based water level controller developed to operate with DRI-STEEM humidifiers. The features of this controller are:

- Water level control (for standard water units)
- Automatic drain and flush
- Variable skim times
- End-of-season drain
- Onboard diagnostics: “Ready water,” “Full,” and “Drain” LEDs to assist troubleshooting

When power is activated, the solenoid-operated water fill valve opens, filling the evaporating chamber. Filling continues until the water reaches level A (see figure on this page), at which time the fill valve closes. To ensure that a water seal is created in the field-installed water seal, disconnect the probe plug and cable from the probe rod assembly (located on top of the tank), allowing the fill valve to re-energize and overflow the humidifier tank. This process takes a short time. Reconnect the probe plug and cable. Create a call for humidify to ensure the steam valve opens.

**IMPORTANT:** The timer logic input wire (see circuit board diagram in this manual) must be connected per the provided wiring diagram for proper automatic drain and flush and end-of-season drain operation. The “Power” light blinks twice at one-second intervals when these functions are disabled. Verify wiring with diagram supplied with unit.

### LW417 water refill

During operation, when the water line drops below level B, the fill valve opens and remains open until the water line returns to level A (see figure this page).

### LW417 low water condition

Should the water line drop below level C, the steam valve is de-energized and remains off until the water line is restored to level C.

**Figure 39-1:**  
**Water level control probe**

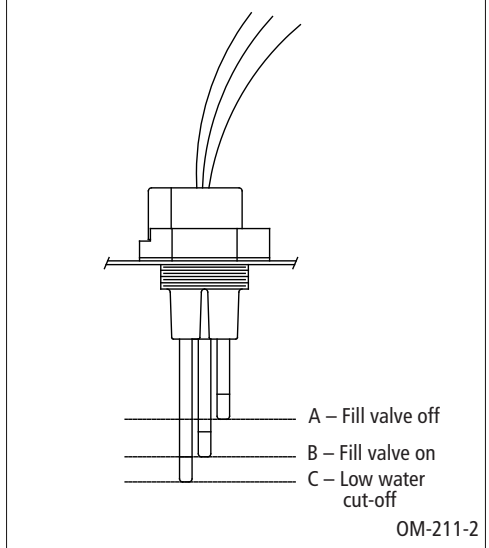

OM-211-2

## Start-up: LW417 control (continued)

**Table 40-1:  
LW417 autodrain settings**

	Switch			Drain time	Interval time
	1	2	3		
Self test	OFF	OFF	OFF	10 mins.	2 mins.
Disabled	ON	OFF	OFF	—	—
Option	OFF	ON	OFF	10 mins.	20 hrs.
Option	ON	ON	OFF	30 mins.	20 hrs.
Factory settings	OFF	OFF	ON	10 mins.	40 hrs.
Option	ON	OFF	ON	30 mins.	40 hrs.
Option	OFF	ON	ON	10 mins.	80 hrs.
Option	ON	ON	ON	30 mins.	80 hrs.

### LW417 automatic drain and flush

The LW417 control module contains an integral electronic timer that tracks the humidifying time of the unit. When this accumulated time reaches what has been set in the timer, the drain/flush cycle is activated.

Upon activation, the following sequence occurs:

1. The drain valve opens, draining the mineral laden water from the evaporating chamber. The default drain time is 10 minutes.
2. Flushing occurs during the last 10% of the drain period.

The electronic timer is factory set for drainage after 40 hours of operation. Alternate settings of 20 hours and 80 hours are available. See the wiring diagram(s) attached to the unit for timer board location and instructions for changing the timer setting or refer to the table on this page.

### Test cycling the drain/flush system

The level control board incorporates a set of slide switches marked 1 through 8. To test:

1. Place “SW1” slide switches 1, 2, and 3 to the off position.
2. Set the humidistat high enough so the unit remains “on call” for at least 15 minutes.
3. After about 2 minutes of operation, activation takes place, causing the drain valve to open. The water level then drops to level C (see figure on the previous page) and allows the fill valve to open. Both valves will remain open for the remainder of the autodrain and flush period.
4. The drain valve then closes, and the water level rises to level A (see figure on the previous page), causing the fill valve to close.
5. Once the test cycle is complete, return the slide switches back to the desired operating mode.

**IMPORTANT: Failure to return the slide switches back to the desired operating mode will result in a drain/flush cycle every 2 minutes.**



# Start-up: LW417 control (continued)

## LW417 variable skim times

The skim time feature removes surface solids and foam from the water. This keeps the fill valve open for a certain amount of time after the water reaches level A (see Figure 39-1 on Page 39). The skim time is factory set for 3 seconds but can be increased for water that requires more skimming. See “Adjusting skim duration” on Page 40. See wiring diagram(s) attached to the unit for timer board location and instructions for changing the skim time setting.

## LW417 end-of-season drain

The end-of-season drain feature drains the tank after 72 hours of no system demand to minimize microbial growth inside the humidifier. When there is a demand for humidity, the tank fills and the unit runs when water reaches the operating level.

## Onboard diagnostics

When the green “Power” light blinks on for one second and then is off for one second, enough scale has accumulated on the probes to begin to compromise the quality of the water level detection. Remove the probe assembly and brush off all scale and tarnish. See the LW417 section of the troubleshooting guide in this manual for other water level control module issues.

## IMPORTANT:

The timer logic input wire (see circuit board diagram below) must be connected per the provided wiring diagram for proper automatic drain and flush and end-of-season drain operation. The “Power” light blinks twice at one-second intervals when these functions have been disabled. Verify wiring with diagram supplied with unit.

**Figure 41-1:**  
**LW417 circuit board**

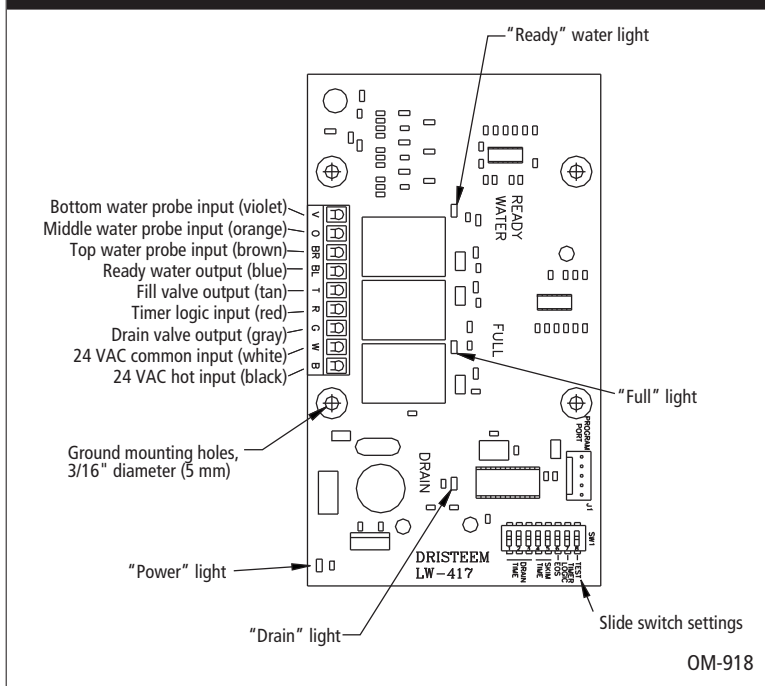

## Operation and maintenance: LTS standard water models

**Table 42-1:  
LW417 skim time settings**

	Switch		Skim time
	4	5	
Option	OFF	OFF	3 seconds
Option	ON	OFF	9 seconds
Factory settings	OFF	ON	32 seconds
Option	ON	ON	45 seconds

### LTS standard water quality recommendations

The best way to determine how often your particular system needs maintenance is to remove the tank cover and inspect it for mineral deposits after three months of duty. Potable water carries a variety of minerals and other materials in a mix that varies from location to location. This variation in water quality, combined with the hours of operation and duty cycle, will determine your own unique maintenance schedule.

### Water quality makes a difference

- Light to moderately hard water (2 to 10 grains hardness per gallon [35 mg/L to 170 mg/L]) requires:
  - Annual cleaning
  - Regular skimming
- High mineral content water (more than 10 grains hardness per gallon [more than 170 mg/L]) requires:
  - Cleaning frequency determined by use and water quality
  - Regular skimming
  - Periodic drain and flush cycles
- Softened water, which dramatically reduces mineral accumulation inside the standard water models, requires:
  - Increased skim time
  - No drain and flush cycles
 (Note: Solids, like silica, are not removed in the softening process.)

### Adjusting skim duration

The skim time duration determines the quantity of water skimmed with each fill cycle. The skim time is field adjustable using the VAPOR-LOGIC<sup>3</sup> keypad or the dip switches on the LW417. See the table on this page.

Each time the LTS refills, it fills to an elevation near the lip of the skim/overflow fitting. A portion of the refill water then flows to the drain carrying most of the minerals left by the previous evaporating cycle. This reduces the mineral concentration, thereby reducing the frequency of cleaning needed.

The heated water that flows to the drain is an operational cost. Cleaning the humidifier is also an operational cost. Therefore, DRI-STEEM recommends that the user observe and adjust the skimming quantity to achieve a balance between minimizing mineral buildup and conserving heated water.

## Operation and maintenance: LTS standard water models (cont.)

### Cool down humidifier before beginning maintenance

Before performing any maintenance, allow the tank to cool down.

- Insulated and uninsulated tanks will have hot surfaces.
- Close the manual shut-off valve on the inlet hot liquid supply.
- For models with a standard drain valve and VAPOR-LOGIC<sup>3</sup>:
  - For drain valves without the manual open lever, use the keypad to perform the cool down process. Refer to the *VAPOR-LOGIC<sup>3</sup> Installation and Operation Manual*.
  - Select Manual Drain in the control modes screen.
  - Allow approximately half the water to drain out of the tank.
  - Select Auto in the control modes screen; the fill valve opens and the humidifier cools down.
  - When the fill valve closes, select Manual Drain in the control modes screen and allow the tank to drain dry. The humidifier should be cool enough to work on.
- Alternative method with the LW417 electronic water level control option:
  - Manually open the drain valve by moving the valve lever located on the back of the drain valve to the manual open position.
  - The fill valve opens when the water drops below the middle probe.
  - Let the fill water run until the tank is cooled; then shut off the field installed manual supply water shut-off valve.
  - Let the tank drain; then manually close the drain valve.

### Inspection and maintenance

#### 1. Annually (also recommended when maintenance is performed)

- Inspect tank and gaskets for leaks.
- All safety devices in the control circuit should be cycled on and off to verify they are functioning. These include:
  - High limit switch
  - Airflow proving switch
  - Low water level probe. Pull out probe plugs and valve should de-energize.

### IMPORTANT SAFETY INFORMATION

When performing maintenance on the LTS humidifier (after the tank has cooled down and drained),

- Always switch the keypad control mode to Standby (VAPOR-LOGIC<sup>3</sup> only).
- Place all power disconnects in OFF position and lock in OFF position.
- Close the field installed manual supply water shut-off valve.
- Close the manual shut-off valve on the inlet steam supply.

## Operation and maintenance: LTS standard water models (cont.)

### Inspection and maintenance (cont.)

#### 2. Seasonally (or as required, depending on water quality)

- Cleaning tank
  - Remove cleanout plate and dispose any loose scale that has collected in the bottom of the tank. This should be done before the scale buildup reaches the bottom of the heat exchanger.
  - Inspect the area inside the tank in front of the drain valve fitting and thoroughly clean all scale and mineral buildup from that area.
- Cleaning the probes
  - Disconnect the probe plug and cable assembly (located on top of the tank) and unscrew the probe rod assembly from the LTS humidifier probe housing.
  - Inspect the probe housing and clean, ensuring that all the housing passageways are clear. To detach the housing from the tank, remove the four bolts that attach it to the tank. Then slide the housing vertically out of the tank.
  - The scale should flake off easily from the probe assembly rods.
  - The bottom 3/8" (10 mm) is the sensing portion of the probe rod; it should be brushed clean with a wire brush, abrasive pad, or steel wool.
  - Inspect the composite plastic probe rod assembly for any signs of cracking, roughness, or deterioration. If found, replace probe assembly.
  - Reassemble the probe assembly.
- Cleaning the skim/overflow port
  - Water should drain from the skimmer drain pipe after each fill cycle. This should be verified visually by a weekly inspection.
  - Loosen deposits in and around the skimmer/overflow port with a long tool such as a screwdriver.
  - If flow through the water seal/P-trap is diminished due to mineral accumulation:
    - Remove the water seal piping from the humidifier and flush out.
    - Replace the water seal with new piping if the minerals have hardened in the water seal.
    - Install a union at the base of the water seal to ease removal if water quality causes the water seal to become clogged often with scale.

---

## Operation and maintenance: LTS standard water models (cont.)

### Inspection and maintenance (cont.)

- When the seasonal maintenance requirements are complete,
  - Tighten down the nuts on the cleanout plate.
  - Verify that the probe rod holder is secure and that the probe plug and cable assembly are plugged into the probe rod holder.
  - Replace and secure all covers.
  - Verify that the drain valve assembly is in the closed position.
  - Turn on the water supply.
  - Turn on the electrical power.
  - Do not leave humidifier unattended. Allow the humidifier to cycle through multiple fill cycles and verify that the humidifier cover, cleanout plate, and probe holder gasket are not leaking.

### 3. Off-season maintenance

- Perform complete inspection and cleaning of the following:
  - Heat exchanger
  - Probe rods
  - Skimmer port and water seal
  - Humidifier tank
- After cleaning, the humidifier should remain empty until humidification is required.

## Operation and maintenance: LTS DI water models

### IMPORTANT SAFETY INFORMATION

When performing maintenance on the LTS-DI humidifier (after the tank has cooled down and drained),

- Always switch the keypad control mode to Standby (VAPOR-LOGIC<sub>3</sub> only).
- Place all power disconnects in OFF position and lock in OFF position.
- Close the field installed manual supply water shut-off valve.
- Close the manual shut-off valve on the inlet steam supply.

### LTS-DI water requirements

- Verify regularly that water processing equipment is operating correctly. The presence of chlorides in improperly processed DI water eventually causes pitting and failure of the heat exchanger tank and its components. Your DRI-STEEM warranty does not cover damage caused by chloride corrosion.
- LTS-DI models do not require regular cleaning, although regular inspections are advised.
- LTS-DI models do not require skimming or draining and flushing to remove precipitated minerals. All DI humidifiers should be drained at the end of a humidification season either by manually opening the drain valve or by programming the humidifier to automatically drain at end-of-season (electric drain valve and VAPOR-LOGIC<sub>3</sub> required).

### Cool down humidifier before beginning maintenance

Before performing any maintenance, allow the tank to cool down.

- Insulated and uninsulated tanks will have hot surfaces.
- Close the manual shut-off valve on the inlet hot liquid supply.
- For models with a standard drain valve:
  - Manually open the drain valve.
  - The float valve opens.
  - Let the fill water run until the tank is cooled; then shut off the field installed manual supply water shut-off valve.
  - Let the tank drain; then manually close the drain valve.
- For models with end-of-season drain option (must have VAPOR-LOGIC<sub>3</sub> controller):
  - Use the keypad to perform the cool down process. Refer to the *VAPOR-LOGIC<sub>3</sub> Installation and Operation Manual*.
  - Select Manual Drain in the control modes screen.
  - Allow approximately half the water to drain out of the tank.
  - Select Auto in the control modes screen; the fill valve opens and the humidifier cools down.
  - When the fill valve closes, select Manual Drain in the control modes screen and allow the tank to drain completely dry. The humidifier should be cool enough to work on.

---

## Operation and maintenance: LTS DI water models

### Inspection

1. **Annually** (also recommended when maintenance is performed)
  - Inspect tank and gaskets for leaks.
  - All safety devices in the control circuit should be cycled on and off to verify they are functioning. These include:
    - High limit switch
    - Airflow proving switch
  - Verify that the float valve is closing off. If the float valve will not shut off, there may be particulate on the valve seat, or the stopper may be worn and need replacing.
  - As long as mineral-free water is used in the LTS-DI, no cleaning or flushing of the humidifier should be necessary.
2. **Off-season maintenance**
  - Perform a complete inspection of the following:
    - Heat exchanger
    - Float valve
    - Humidifier tank and gaskets
  - After inspection, the humidifier should remain empty until humidification is required.
  - After the humidification season, DRI-STEEM recommends a complete inspection and cleaning of the heat exchanger and water chamber. After cleaning, the unit should remain empty until humidification is required.

# Troubleshooting

**Table 48-1:  
LTS and LTS-DI troubleshooting guide**

Symptom	Possible cause	Recommended action
Humidifier will not heat.	No control transformer output	Verify control voltage.
	Humidistat is not calling.	Inspect for faulty humidistat. Set humidistat to "call."
	Safety controls are open (high limit, air proving switch, etc.)	Check safety controls.
	Faulty control board	See LW417 troubleshooting guide in this manual, or see the VAPOR-LOGIC <sub>3</sub> troubleshooting guide in the <i>VAPOR-LOGIC<sub>3</sub> Installation and Operation Manual</i> .
	Probe corrosion	Replace probes. Note: Although the three stainless steel probes eventually erode due to corrosion, they usually are functional up to approximately 5,000 hours of operation.
	Liquid control valve is closed.	Verify valve is open.
	Low or no liquid flow	Verify valve is open.
	Liquid strainer is plugged.	Clean strainer.
Humidifier will not fill.	No water pressure	Verify that manual water supply valve is open with a minimum water supply pressure of 25 psi (172 kPa).
	Faulty water fill valve	Verify action of fill solenoid valve. Verify control voltage is present at coil. An audible click should be heard as the solenoid opens.
	Plugged water strainer	Clean strainer.
	Plugged valve	Clean valve.
	Faulty control board	Verify control voltage.
Humidifier does not stop filling.	Lack of tank-to probes continuity	Connect violet, orange, and then brown jumper wires to ground. If water stops, verify tank ground.
	Water conductivity is too low (less than 100 µS/cm [2 grains/gallon])	Check water supply conductivity; then consult factory.
	Manual drain is not fully closed.	Close manual ball valve.
	Fill valve is stuck open.	Check valve for foreign matter.
	Fill valve is installed backward.	Check for correct water flow through valve; note arrow.
Low output	Automatic drain valve not seating	Clean ball and seat of valve.
	Manual drain not fully closed	Close manual ball valve.
	Excessive skimming amount	Reduce skim time. See the LW417 control section in this manual, or see the <i>VAPOR-LOGIC<sub>3</sub> Installation and Operation Manual</i> for instructions on how to adjust skim duration.
	Fill valve is stuck open.	Check valve for foreign matter. Check if the valve is installed backward (check water flow; note arrow).
	Low or no liquid flow	Check high temperature liquid source.
	Liquid control valve inoperable	Valve not opening fully. Check signal to valve.
	Scale-coated heat exchanger	Clean heat exchanger.

**Note:**  
For VAPOR-LOGIC<sub>3</sub> troubleshooting, see the *VAPOR-LOGIC<sub>3</sub> Installation and Operation Manual*.



## Troubleshooting (cont.)

**Table 49-1:  
LW417 troubleshooting guide**

Symptom	Module indicating lights			Possible cause	Recommended action
	Full	Ready water	Drain		
Humidifier will not heat.	Off	Off	Off	Control transformer	Verify control voltage across secondary leads of transformer. Reset transformer circuit breaker.
	On	On	Off	Humidistat is not calling.	Set humidistat to call. Inspect for faulty humidistat or wiring.
				Safety controls are open.	Check safety controls (airflow proving switch, high limit switch, etc.).
				Faulty control board	Verify control voltage between input terminals "B" and "W."
Off	Off	Off	Not enough water in tank; water supply closed	Open water valve.	
Humidifier will not heat, the "Ready Water" indicator is off, and there is enough water in the tank for operation (water is touching the bottom probe).	Off	Off	Off	Low water conductivity	Add salt to increase conductivity to 100 µS/cm (2 grains/gallon) minimum.
				Probe corrosion	Clean water probe tips.
				Wiring or LW417 board malfunction	Connect jumper wire from violet to white wire. If "Ready Water" indicator remains off, replace module.
				Water detection wire malfunction	Check that tank and the 24 VAC common side of power are at same potential.
Humidifier will not heat, and the green LED power light is blinking (on for 1 second, off for 1 second)	Off	Off	Off	System detected faulty probe rod assembly.	Clean probes or replace probe assembly.
Humidifier will not fill.	On	Off	Off	Faulty "Full" relay on LW417 board.	Unplug probe assembly plug from humidifier probe head; "Fill" LED light should be off. Check for 24 VAC across fill valve coil. If not present, "Full" relay is defective. Replace module.
	Off	Off	Off	Wiring malfunction	Ensure that: <ul style="list-style-type: none"> <li>• Fill valve is wired to drain valve output</li> <li>• Water detection probe wiring is correct</li> <li>• Wiring distance between probe assembly and LW417 board is not greater than 30' (9 m)</li> </ul>
	Off	On	Off	System is in end-of-season drain mode.	Create a call for humidity to reset the system and energize the fill valve.

More on next page ►

## Troubleshooting (cont.)

**Table 50-1 (continued):  
LW417 troubleshooting guide**

Symptom	Module indicating lights			Possible cause	Recommended action
	Full	Ready water	Drain		
Humidifier does not stop filling.	Off	Off	On	System is in autodrain mode.	Wait until autodrain completes (ten minutes).
	On	Off	Off	LW417 fill valve relay is faulty	If the "Full" LED light on the control module is on and the fill valve is energized, the module is defective. Replace.
	Off	Off	Off	Control module wiring malfunction	<ul style="list-style-type: none"> <li>Check wires for proper connections to control module. See wiring diagram.</li> <li>Ensure wiring distance between humidifier tank and water level control is not greater than 30' (9 m).</li> </ul>
				Faulty logic from LW417	If the "Full" LED light on the control module is off and the tank is full, the module is defective. Replace.
Low output	On	On	Off	Faulty "ready water" detection	<ul style="list-style-type: none"> <li>Install jumper wire between violet and white wire leads, which should activate "Ready Water" LED light and relay. If not activated, module is defective. Replace.</li> <li>Ensure wiring distance between probe assembly and LW417 board is not greater than 30' (9 m).</li> <li>Do not use shielded (screened) cable when wiring water detection probe system between the humidifier and controller; use 18-gauge (1 mm<sup>2</sup>) individual stranded wire.</li> </ul>
					On
Unit short cycles	On and off	On	Off	Probes are incorrectly wired or need cleaning.	<ul style="list-style-type: none"> <li>Confirm that the probe assembly is wired per the wiring diagram.</li> <li>Clean probe rod tips with steel wool.</li> </ul>

# Replacement parts

**Figure 51-1:**  
**LTS tank replacement parts**

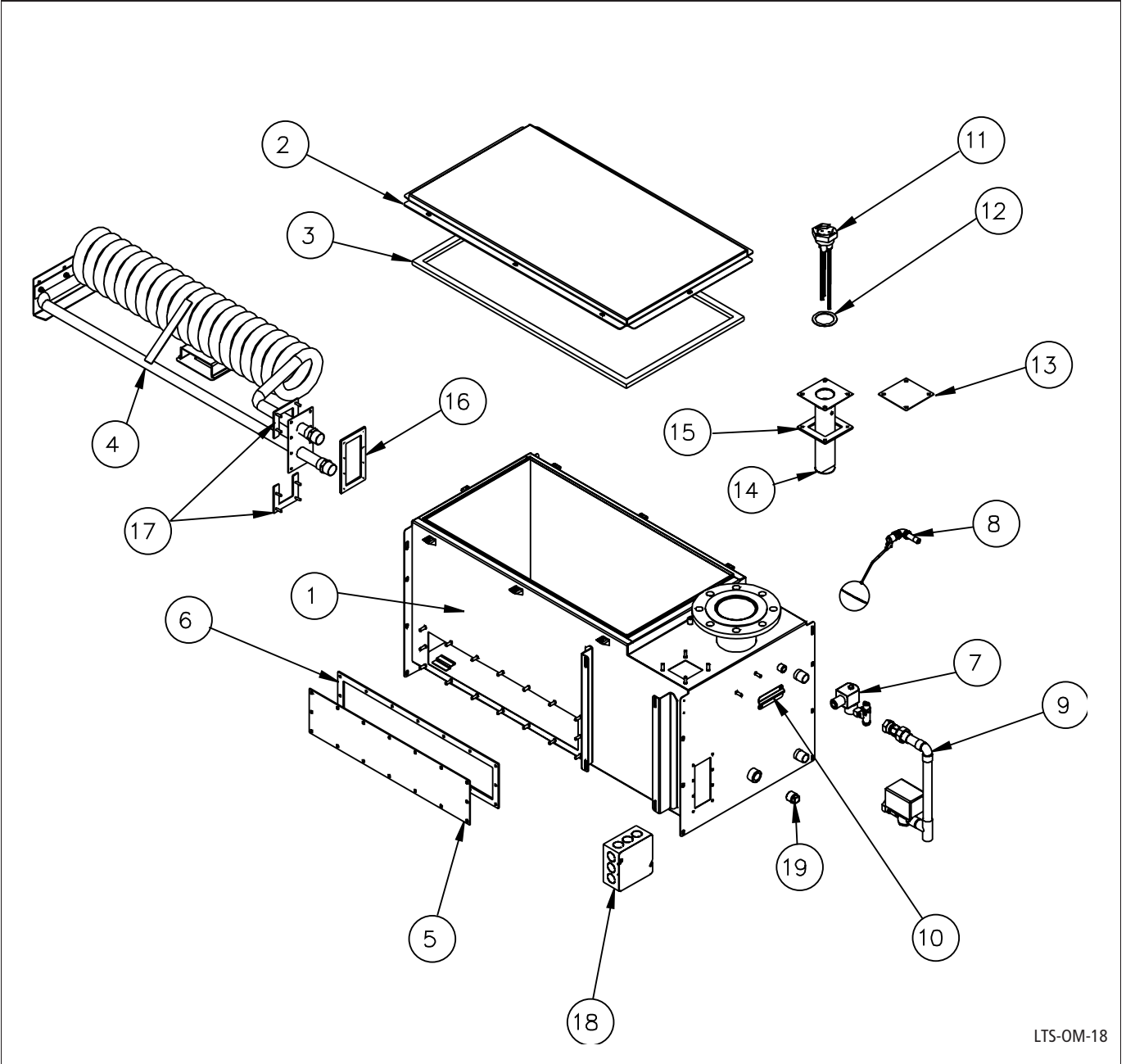

LTS-OM-18

## Replacement parts (cont.)

**Table 52-1:  
LTS tank replacement parts**

Number in drawing	Description	Part number
1	Tank, LTS	*
2	Cover, LTS-25	165341-001
2	Cover, LTS-100	165341-003
2	Cover, LTS-400	165341-004
3	Cover gasket, LTS-25	160692-001
3	Cover gasket, LTS-100	160692-003
3	Cover gasket, LTS-400	160692-004
4	Heat exchanger, LTS	*
5	Cleanout plate, LTS-25	165481-001
5	Cleanout plate, LTS-100	165481-002
5	Cleanout plate, LTS-400	165481-003
6	Cleanout plate gasket, LTS-25	308015-001
6	Cleanout plate gasket, LTS-100	308015-002
6	Cleanout plate gasket, LTS-400	308015-003
7	Fill assembly	*
8	Float fill assembly, LTS-25/100	505315
8	Float fill assembly, LTS-400	505305
9	Drain assembly	*
10	Temperature sensor assembly	405760
11	Probe assembly	406303-008
12	Probe gasket	309350-004
13	Probe plate, DI water	120370-020
14	Probe weld, standard water	165301
15	Probe plate/weld gasket	308416-001
16	Heat exchanger gasket	308220
17	Heat exchanger mounting plate	164581-001
18	Junction box	407134-005/006
19	Condensate return plug	250192-075

**Note:**

\* Contact your local representative with your model number when ordering this part. Components may in be different locations than shown in drawing.

# Replacement parts (cont.)

**Figure 53-1:**  
**Control cabinet replacement parts**

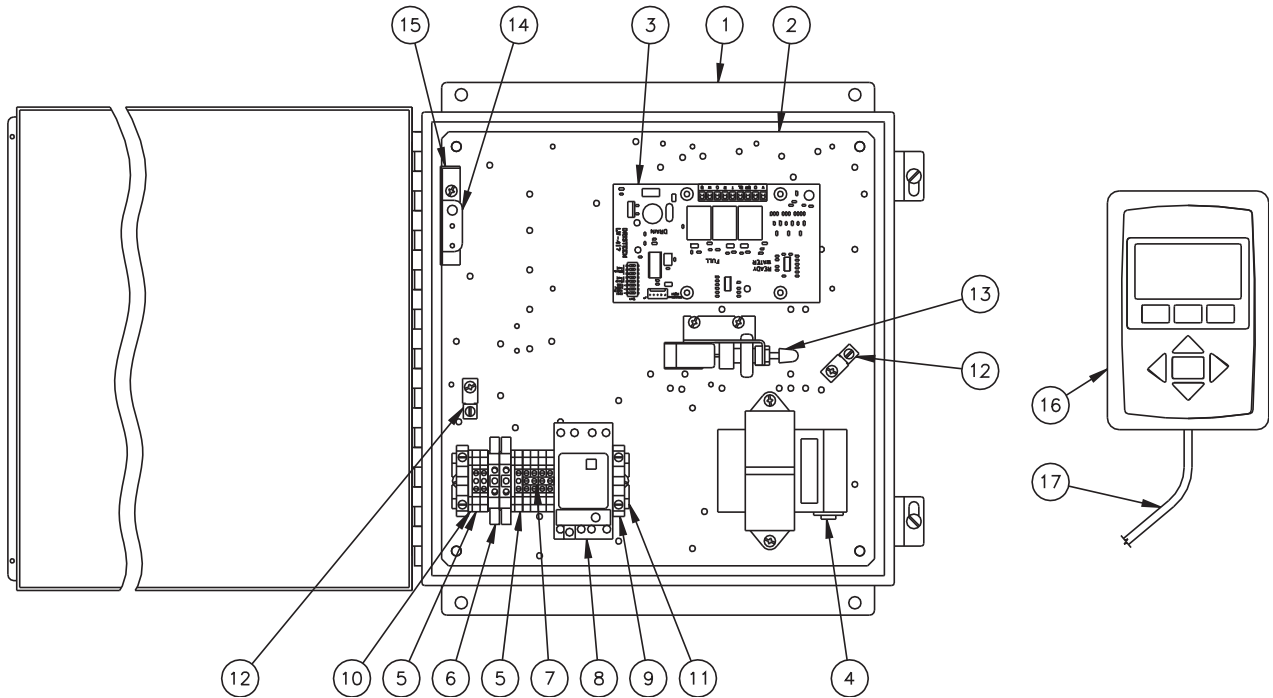

**Note:**  
Components may be in different locations than shown in drawing.

OM-949

## Replacement parts (cont.)

**Table 54-1:  
Control cabinet replacement parts**

Number in drawing	Description	Part number
1	Control cabinet, 12" x 12"	407100-003
2	Subpanel, LTS	165720-002
3	Control board, VAPOR-LOGIC <sub>3</sub>	408632
3	Control board, LW417	408490-001
4	Transformer, 120V to 24V	408965-001
5	Terminal block	408252-001
6	Ground terminal	408252-010
7	Terminal jumper	408252-009
8	AREA-TYPE™ time delay relay	407900-010/016/018
9	DIN-rail end cap	408252-006
10	Terminal spacer	408252-005
11	DIN-rail, 6.5" (165 mm)	167765-006
12	Ground lug	409250-003
13	P-E switch	408100
14	Interlock switch	408470
15	Interlock switch bracket	165614
16	VAPOR-LOGIC <sub>3</sub> keypad	408490-002
17	VAPOR-LOGIC <sub>3</sub> keypad cable, 5' (1.5 m)	408490-009

# LTS maintenance service record

Date inspected	Personnel	Observation	Action performed

### Expect quality from the industry leader

For more than 35 years, DRI-STEEM has been leading the industry with creative and reliable humidification solutions. Our focus on quality is evident in the construction of the LTS, which features cleanable, stainless steel construction, and an industry-leading two year warranty that covers all parts.

### For more information

www.dristeem.com  
sales@dristeem.com

### DRI-STEEM Humidifier Company

An ISO 9001 certified company  
and a subsidiary of  
Research Products Corporation

U.S. Headquarters:  
14949 Technology Drive  
Eden Prairie, MN 55344  
800-328-4447  
952-949-2415  
952-229-3200 (fax)

European office:  
Bell Place, Bell Lane  
Syresham, Brackley  
NN13 5HP, UK  
+44 1280 850122 (voice)  
+44 1280 850124 (fax)  
E-mail: 106277.1443@compuserve.com

DRI-STEEM, DRI-CALC, LTS, RAPID-SORB,  
ULTRA-SORB, and VAPOR-LOGIC are  
registered trademarks of DRI-STEEM  
Humidifier Company.

AREA-TYPE and DRANE-KOOLER are  
trademarks of DRI-STEEM Humidifier  
Company.

DRI-STEEM, DRI-CALC, LTS, RAPID-SORB,  
ULTRA-SORB, and VAPOR-LOGIC are filed  
for trademark registration in Canada and  
the European community.

© 2003 DRI-STEEM Humidifier Company



Form No. LTS-IOM-0603-global  
Part No. 890000-301 Rev A

### Two-year limited warranty

DRI-STEEM Humidifier Company (“DRI-STEEM”) warrants to the original user that its products will be free from defects in materials and workmanship for a period of two (2) years after installation or twenty-seven (27) months from the date DRI-STEEM ships such product, whichever date is the earlier.

If any DRI-STEEM product is found to be defective in material or workmanship during the applicable warranty period, DRI-STEEM’s entire liability, and the purchaser’s sole and exclusive remedy, shall be the repair or replacement of the defective product, or the refund of the purchase price, at DRI-STEEM’s election. DRI-STEEM shall not be liable for any costs or expenses, whether direct or indirect, associated with the installation, removal or reinstallation of any defective product.

DRI-STEEM’s limited warranty shall not be effective or actionable unless there is compliance with all installation and operating instructions furnished by DRI-STEEM, or if the products have been modified or altered without the written consent of DRI-STEEM, or if such products have been subject to accident, misuse, mishandling, tampering, negligence or improper maintenance. Any warranty claim must be submitted to DRI-STEEM in writing within the stated warranty period.

DRI-STEEM’s limited warranty is made in lieu of, and DRI-STEEM disclaims all other warranties, whether express or implied, including but not limited to any IMPLIED WARRANTY OF MERCHANTABILITY, ANY IMPLIED WARRANTY OF FITNESS FOR A PARTICULAR PURPOSE, any implied warranty arising out of a course of dealing or of performance, custom or usage of trade.

DRI-STEEM SHALL NOT, UNDER ANY CIRCUMSTANCES BE LIABLE FOR ANY DIRECT, INDIRECT, INCIDENTAL, SPECIAL OR CONSEQUENTIAL DAMAGES (INCLUDING, BUT NOT LIMITED TO, LOSS OF PROFITS, REVENUE OR BUSINESS) OR DAMAGE OR INJURY TO PERSONS OR PROPERTY IN ANY WAY RELATED TO THE MANUFACTURE OR THE USE OF ITS PRODUCTS. The exclusion applies regardless of whether such damages are sought based on breach of warranty, breach of contract, negligence, strict liability in tort, or any other legal theory, even if DRI-STEEM has notice of the possibility of such damages.

By purchasing DRI-STEEM’s products, the purchaser agrees to the terms and conditions of this limited warranty.