

---

**DRISTEEM**<sup>®</sup>  
The humidification experts

**Vapormist**<sup>®</sup>  
Electric Humidifier

**Installation, Operation  
and Maintenance Manual**



---

**ATTENTION INSTALLER**

Read this manual before installing.  
Leave manual with product owner.

**DRI-STEEM® technical support**

800-328-4447

---

**WARNING!**

Disconnect electrical power before installing supply wiring. Contact with energized circuits can cause severe personal injury or death as a result of electrical shock.

This product must be installed by qualified HVAC and electrical contractors and in compliance with local, state, federal, and governing codes. Improper installation can cause property damage, severe personal injury, or death as a result of electric shock, burns, and/or fire.

The humidifier tank, dispersion assembly, and all connected hose or piping can contain or discharge hot steam and/or hot water at 212 °F (100 °C). Discharged steam is not visible. Contact with hot surfaces, discharged hot water, or air into which steam has been discharged can cause severe personal injury.

Failure to follow the instructions in this manual can cause moisture to accumulate, which can cause bacteria and mold growth or dripping water into building spaces. Dripping water can cause property damage; bacteria and mold growth can cause illness.

Supply water pressure greater than 80 psi (550 kPa) can cause the humidifier to overflow.

---

# Table of contents

## Product overview

Product overview .....	2
Electrical specifications, capacities and weights .....	4
Dimensions .....	5

## Installation

Choosing a location for the humidifier.....	6
Mounting the humidifier .....	7
Clearance recommendations .....	7
Supply water and drain piping.....	8
Wiring .....	11
Humidistat and transmitter placement.....	13
Dispersion .....	14
Selecting the dispersion assembly location.....	14
Interconnecting piping requirements .....	15
Drip tee installation .....	17
SDU-I and SDU-E .....	18
Single tube .....	22
Rapid-sorb .....	24

## Operation

Start-up procedure.....	31
-------------------------	----

## Maintenance

Standard water models maintenance .....	32
DI/RO water models maintenance .....	36
Replacement parts .....	38
Two-year limited warranty .....	Back cover

## Keypad and troubleshooting information

The *Vapor-logic<sup>3</sup> Installation and Operation Manual*, which was shipped with your humidifier, is a comprehensive operation manual. Refer to it for information about using the keypad and for troubleshooting information.

## Download DRI-STEEM literature

Most DRI-STEEM<sup>®</sup> product manuals can be downloaded, printed, and ordered from our web site: [www.dristeem.com](http://www.dristeem.com)

## Product overview

### Note:

See Pages 8 and 9 for detailed installation drawings.

**Figure 2-1:**  
Water level control for standard water systems

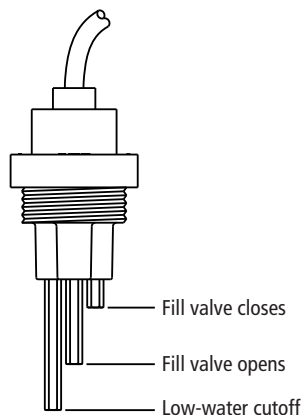

Systems using tap or softened water control water levels electronically using a three-rod probe. The controller responds with the above actions when the water level reaches each rod.

VLC-OM-030

**Figure 2-2:**  
Water level control for DI/RO water systems

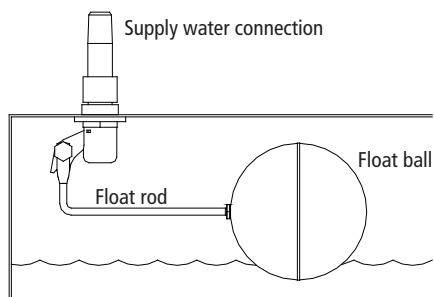

Systems using deionized (DI) water or water that has been treated through reverse osmosis (RO) control water levels using a float valve and low water cutoff switch.

OM-7396

**Figure 2-3:**  
Installation overview (Vapormist standard water model shown)

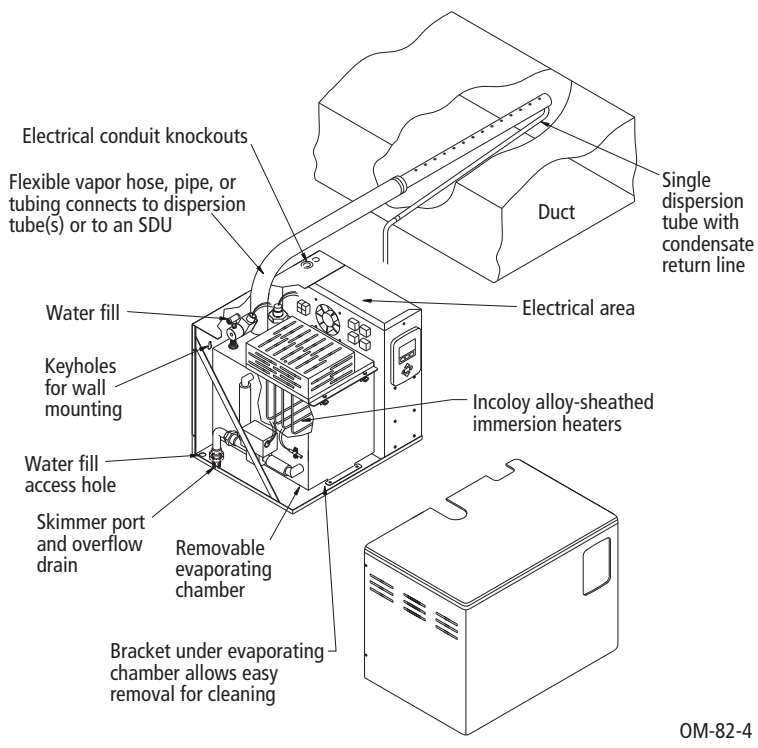

OM-82-4

### Vapormist® standard water models control water levels with an electronic probe

Vapormist® standard water models (shown above) require supply water conductivity to be at least 100  $\mu\text{S}/\text{cm}$  to operate. These models use an electronic probe to monitor water levels (see Figure 2-1). Standard water models will not operate with water treated by reverse osmosis (RO) or deionization (DI) processes.

### Vapormist-DI models control water levels with a float valve

Vapormist-DI models are designed specifically for use with DI/RO water. These models use a float valve to control water levels (see Figure 2-2). Vapormist-DI models will not operate with standard (potable) water.

### Convert to a different water type in the field

Vapormist standard water models can be converted in the field for use with DI/RO water. Vapormist-DI models can be converted in the field for use with potable or softened water. Contact your DRI-STEEM® representative or distributor for parts and instructions.

## Product overview, continued

### Dispersion assembly options

In addition to single tube dispersion, shown in Figure 2-3, the dispersion options shown on this page are available for Vapormist humidifiers. See pages 14-30 for installation instructions.

**Figure 3-1:**  
**Ultra-sorb® dispersion**

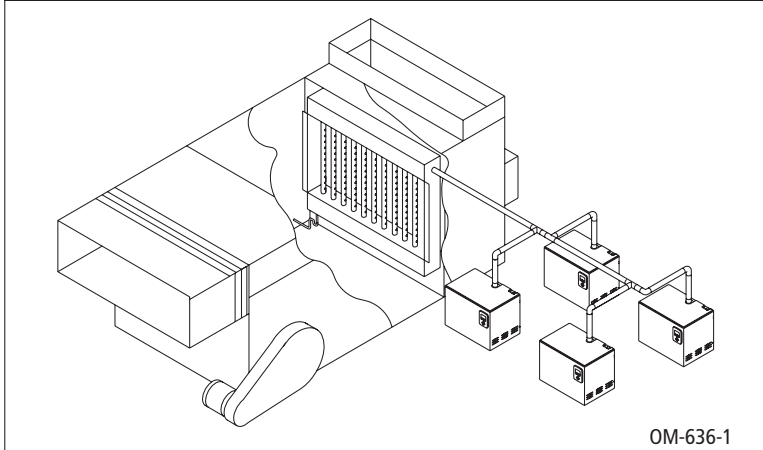

**Figure 3-2:**  
**Rapid-sorb® dispersion**

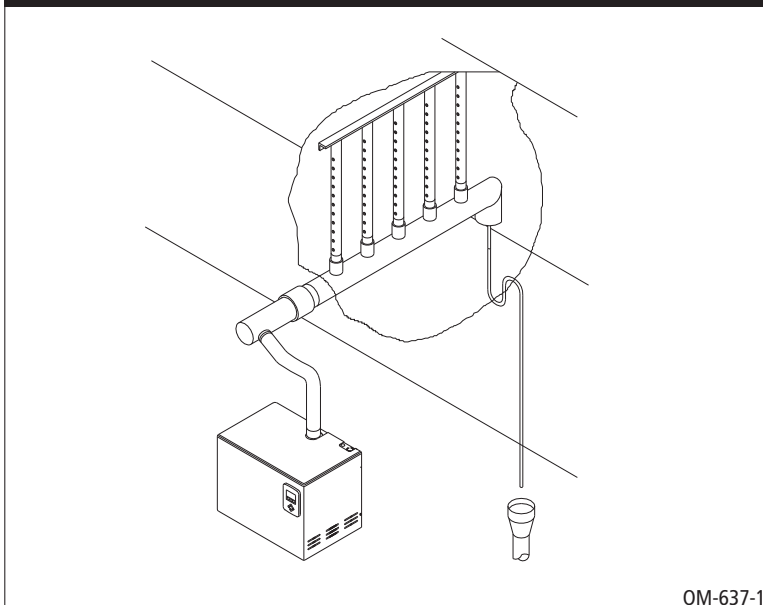

**Figure 3-3:**  
**SDU-E**

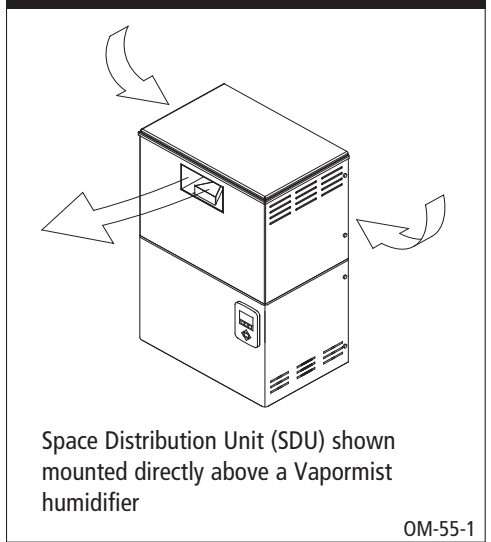

**Figure 3-4:**  
**SDU mounted remotely**

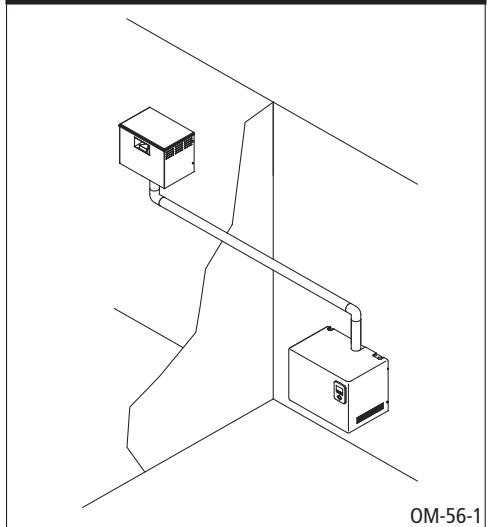

# Specifications, capacities, and weights

**Table 4-1:  
Vapormist specifications, capacities, and weights**

Model	Maximum steam capacity		Current draw (amps)									Weights ‡			
			Single-phase					Three-phase				Shipping		Operating	
kW	lbs/hr	kg/h	120V	208V*	240V*	480V†	600V†	208V*	240V†	480V†	600V†	lbs	kg	lbs	kg
2	6	2.7	16.7	9.6	8.3	4.2	3.3	—	—	—	—	80	36	95	43
4	12	5.4	33.3	19.2	16.7	8.3	6.7	16.7**	14.4**	7.2**	5.8**	80	36	95	43
6	18	8.2	—	28.8	25.0	12.5	10.0	25.0**	21.7**	10.8**	8.7**	88	40	122	55
8	24	10.9	—	38.5	33.3	16.7	13.3	33.3**	28.9**	14.4**	11.5**	88	40	122	55
10	30	13.6	—	—	41.7	20.8	16.7	29.1**	25.3**	12.6**	10.1**	93	42	139	63
12	36	16.3	—	—	—	25.0	20.0	33.3	28.9	14.4	11.5	93	42	139	63
14	42	19.1	—	—	—	29.2	23.3	38.9	33.7	16.8	13.5	93	42	139	63
16	48	21.8	—	—	—	33.3	26.7	44.4	38.5	19.2	15.4	93	42	139	63
21	63	28.6	—	—	—	43.8	35.0	—	—	25.3	20.2	95	43	152	69
25	75	34.0	—	—	—	—	41.7	—	—	30.1	24.1	95	43	152	69
30	90	40.9	—	—	—	—	—	—	—	36.1	28.9	101	46	156	71
34	102	46.3	—	—	—	—	—	—	—	40.9	32.7	101	46	156	71

**Notes:**

- \* On 208V/240V/single-phase/three-wire and on 208V/three-phase/four-wire supplies, the neutral line provides a separate 120V circuit for the SDU fan unit.
  - \*\* For wire sizing, the highest leg draw is shown due to current imbalance.
  - † Add the following to Vapormist weights if using an SDU option (these weights are for additional control components housed within the Vapormist cabinet):
    - SDU-I: 12 lbs (5.5 kg)
    - SDU-E: 9 lbs (4 kg)
 See the SDU weights Table 4-2 below for SDU weights (shipped separately).
  - ‡ Add the following if using the SSR option:
    - For single-phase or three-phase models drawing less than 21.7 amps, add 2 lbs (1 kg)
    - For three-phase models drawing more than 21.7 amps, add 4 lbs (2 kg)
- All Vapormists operate at 50/60 Hz.

**Notes about SDUs (Space Distribution Units):**

- The SDU-I is available for models VM-2 through VM-8, and all VM-10 models except those using 240V, three-phase power with SSR control.
- The SDU-E is available for all Vapormist models except those models using 240V/480V/600V/three-phase power with the SSR control option and drawing more than 21.7 amps.
- SDUs ship separately from the Vapormist.

**Table 4-2:  
SDU weights**

SDU model	Shipping weight		Operating weight	
	lbs	kg	lbs	kg
SDU-I	68	31	58	26
SDU-E	61	28	51	23

# Dimensions

**Figure 5-1:  
Dimensions**

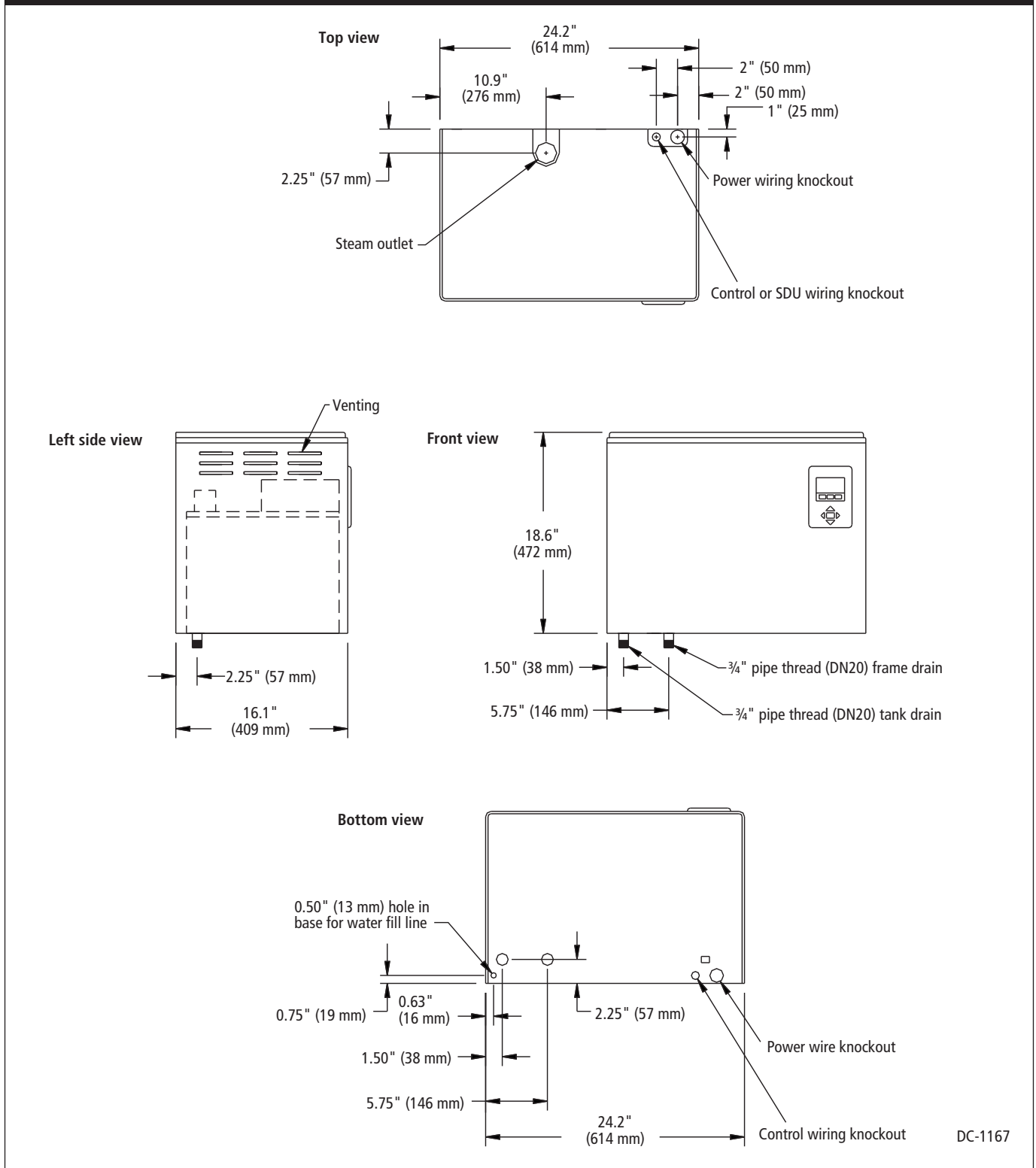

---

## Choosing a location

### Choosing a location for the humidifier

When selecting a location for the humidifier, consider the following:

- **Proximity to duct**

Install the humidifier near the air duct system where the dispersion assembly will be located. The maximum recommended length for vapor hose connecting a single humidifier to a dispersion assembly is 10' (3 m). The maximum recommended developed length for tubing or pipe connecting a single humidifier to a dispersion assembly is 20' (6 m). See the dispersion section of this manual for more information about installing dispersion assemblies.

- **Elevation of the installed dispersion assembly**

The recommended installation location for the dispersion assembly is at an elevation higher than the humidifier. However, if the dispersion assembly must be installed at an elevation lower than the humidifier, install a drip tee and drain as shown in Figure 17-1. Before installing a dispersion assembly or interconnecting piping, review all pitch requirements in the dispersion section of this manual.

- **Required clearances** (see Figure 7-1)

- **Electrical connections**

Electrical power supply connections are made at the lower or upper right rear corner of the unit. See the field wiring instructions starting on Page 11.

- **Supply water and drain piping connections**

Water supply piping and drain connections are made at the lower left rear corner of the unit. See the field piping illustrations and instructions starting on Page 8.

- **Exterior wall insulation**

Do not install the humidifier on an exterior wall unless that wall is properly insulated.

### Choosing a location for the dispersion control devices

See Figure 13-1 for recommended installation locations for the dispersion assembly and associated control devices.



## Mounting the humidifier

### Mounting the humidifier on the wall

When mounting on a wood stud wall (studs 16" [406 mm] on center), locate studs and position lag bolts in place so that each of the bolts centers on a stud. Mark hole locations and predrill ¼" (6 mm) diameter pilot holes. Secure cabinet to wall with lag bolts provided.

When mounting on a metal stud wall, locate the studs (16" [406 mm] on center) and drill a 3/8" (10 mm) hole through the studs and wall. Push a 3/8" (10 mm) bolt through the wall, studs, and a backing plate on the backside of the wall and secure with a nut and washer.

If 16" (406 mm) on-center studs are not available, mount spanner boards on the wall, spanning two studs. If two horizontal boards are used, locate one at the top of the cabinet for the lag bolts and the other board located 3" (76 mm) on center from the bottom of the cabinet.

For hollow block or poured concrete wall mounting, position template in place and mark the holes. Drill appropriate pilot holes for two 3/8" (10 mm) toggle bolts or two 3/8" (10 mm) machine bolt lead anchors. Secure cabinet in place.

### **WARNING!**

Mount humidifier per the instructions in this manual and to a structurally stable surface. Improper mounting of humidifier can cause the humidifier to fall off the wall resulting in severe personal injury or death.

**Figure 7-1:**  
**Clearance recommendations**

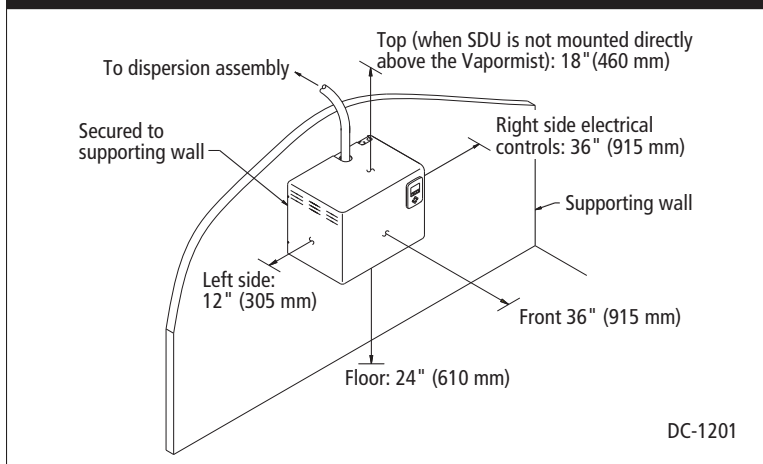

# Vapormist piping, standard water models

**Figure 8-1:**  
**Vapormist (standard water models) field piping overview**

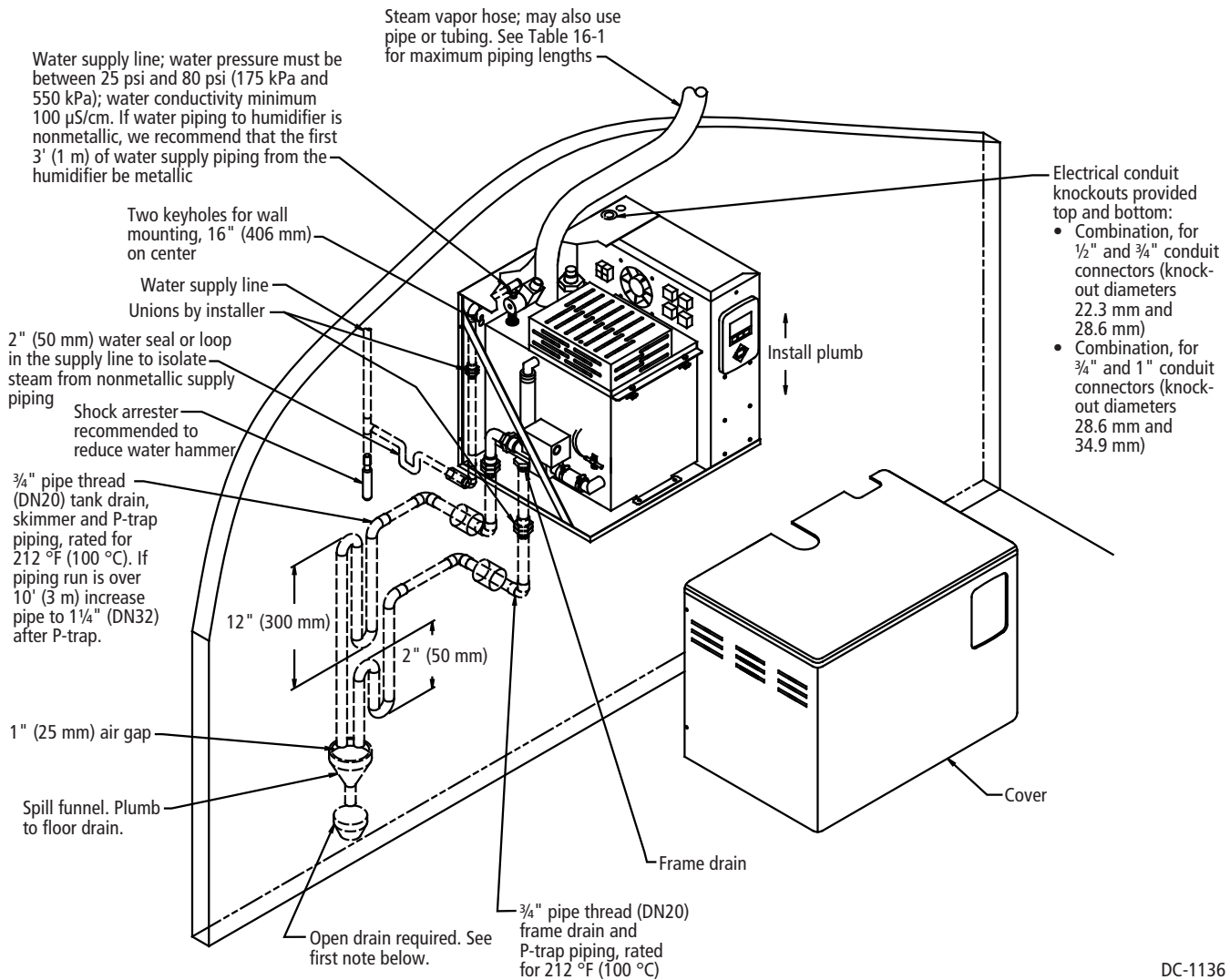

DC-1136

**Notes:**

- Locate air gap only in spaces with adequate temperature and air movement to absorb flash steam; otherwise, condensation may form on nearby surfaces. Refer to governing codes for drain pipe size and maximum discharge water temperature.
- Offset humidifier from spill funnel or floor drain to prevent flash steam from rising into the cabinet.
- Dashed lines indicate provided by installer.
- The water supply inlet is more than 1" (25 mm) above the skim/overflow port, eliminating the possibility of backflow or siphoning from the tank. No additional backflow prevention is required; however, governing codes prevail.
- Install a union in the water supply and drain lines as shown to allow tank removal.
- Damage caused by chloride corrosion is not covered by your DRI-STEEM warranty.
- See the next page for recommended piping for Vapormist-DI models (models that use DI/RO water).
- See the dispersion section of this manual for more information about piping that connects the humidifier to the dispersion assembly.

# Vapormist piping, DI/RO water models

**Figure 9-1:**  
**Vapormist-DI (deionized/reverse osmosis water models) field piping overview**

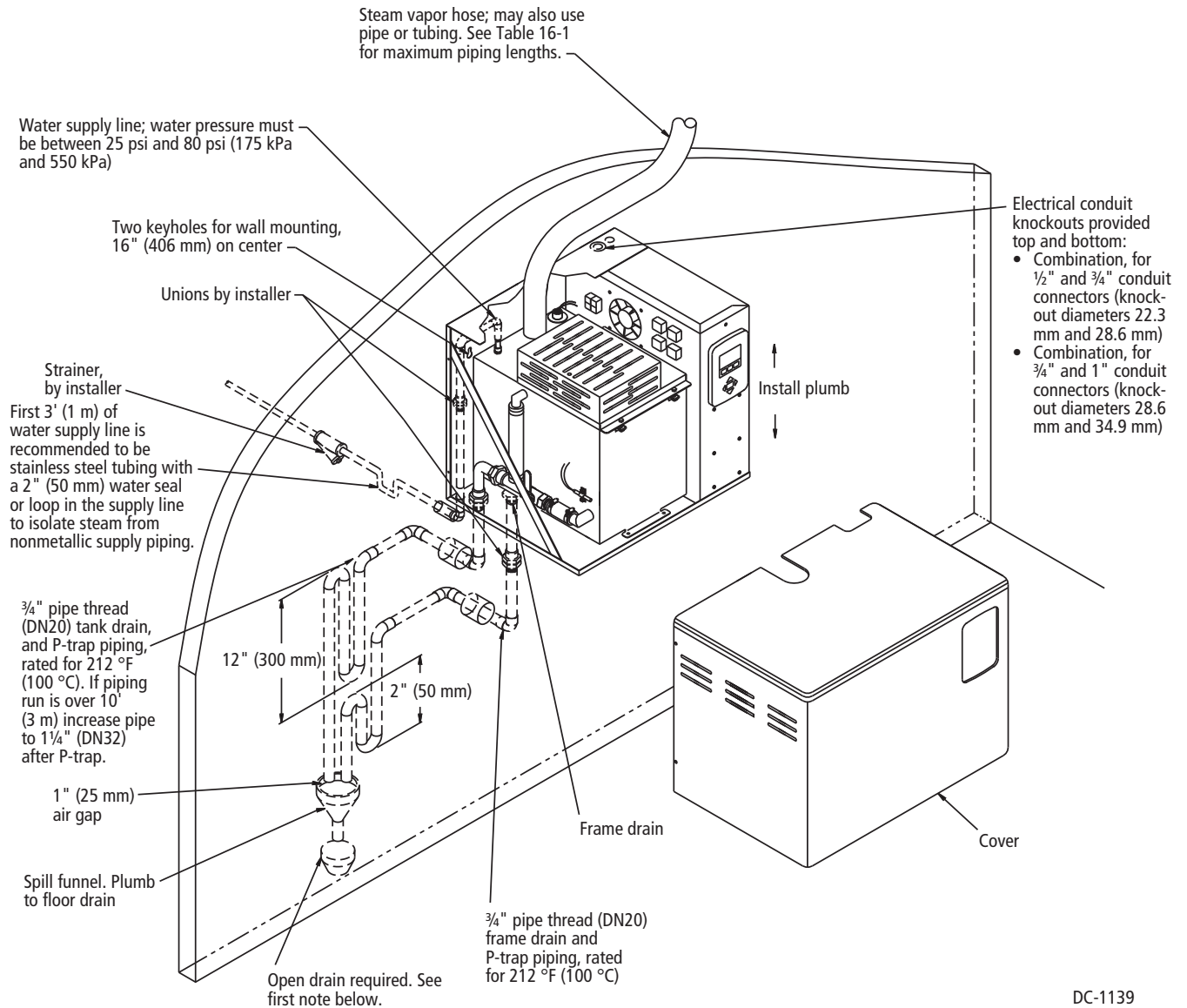

**Notes:**

- Locate air gap only in spaces with adequate temperature and air movement to absorb flash steam; otherwise, condensation may form on nearby surfaces. Refer to governing codes for drain pipe size and maximum discharge water temperature.
- Offset humidifier from spill funnel or floor drain to prevent flash steam from rising into the cabinet.
- Dashed lines indicate provided by installer.
- The water supply inlet is more than 1" (25 mm) above the overflow port, eliminating the possibility of backflow or siphoning from the tank. No additional backflow prevention is required; however, governing codes prevail.
- Install a union in the water supply and drain lines as shown to allow tank removal.
- Damage caused by chloride corrosion is not covered by our DRI-STEEM warranty.
- See the previous page for recommended piping for Vapormist standard water models.
- See the dispersion section of this manual for more information about piping that connects the humidifier to the dispersion assembly.

## Supply water and drain piping

### WARNING!

Opening the drain valve when the tank is hot can discharge water with a temperature up to 212 °F (60 °C) into the plumbing system. This can cause damage to the plumbing system if the humidifier is not properly connected to a water tempering device such as a DRI-STEEM Drane-kooler™.

Do not touch the tank or drain piping until the unit has had sufficient time to cool, or serious injury can occur.

**Figure 10-1:**  
Drane-kooler water tempering device

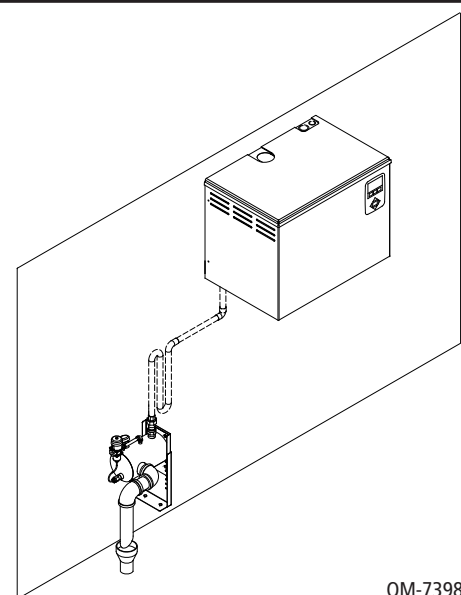

DRI-STEEM's Drane-kooler, shown mounted to a Vapormist humidifier, tempers discharged water. For other Drane-kooler mounting options or for more information, contact your DRI-STEEM representative/distributor, or view the Drane-kooler product data sheet in the literature section at [www.dristeem.com](http://www.dristeem.com)

### Supply water and drain piping

Supply water piping may be of any code-approved material (copper, steel, or plastic). The fill valve connection size is a ¼" pipe thread (DN8) fitting except in Europe where it is a DN10 pipe thread fitting. In cases where water hammer may be a possibility, consider installing a shock arrestor. Water pressure must be between 25 psi and 80 psi (175 kPa and 550 kPa).

If water piping to humidifier is nonmetallic, we recommend that the first 3' (1 m) of water supply piping from the humidifier be metallic with a 2" (50 mm) water seal or loop in the supply line to isolate steam from nonmetallic supply piping.

Drain piping may be of any code-approved material (copper, steel, or plastic rated for 212 °F [100 °C] minimum). If drainage by gravity is not possible, use a reservoir pump rated for 212 °F (100 °C) water (DRI-STEEM Part No. 400280 for 120V pump and Part No. 400281 for 230V pump).

The final connection size is ¾" (DN20) copper for the tank and frame drains. Do not reduce this connection size. Pipe the tank and frame drains separately, as shown in Figures 8-1 and 9-1, to prevent backflow of drain water into the humidifier cabinet.

If the equivalent length of pipe from the humidifier drain to the plumbing system drain is more than 10' (3 m), increase the pipe size to 1¼" (DN32).

See Figures 8-1 and 9-1 for more piping instructions.

**Important:** Install unions in the water supply and drain lines as shown in Figures 8-1 and 9-1 to allow tank removal.

---

# Vapormist wiring

## Humidifier field wiring

All wiring must be in accordance with all governing codes, and with the humidifier wiring diagrams. The diagrams are located inside the removable subpanel cover on the right side of the humidifier cabinet. Power supply wiring must be rated for 220 °F (105 °C).

When selecting a location for installing the Vapormist, avoid areas close to sources of electromagnetic emissions such as power distribution transformers.

The use of semiconductor fusing sized per the National Electric Code is recommended with the SSR option.

## Grounding requirements

The approved earth ground must be made with solid metal-to-metal connections and must be a good conductor of radio frequency interference (RFI) to earth (multistranded conductors).

Ground wire should be the same AWG (mm<sup>2</sup>) size as the power wiring or sized per NEC requirements (in Europe, IEC 60364 requirements).

## Proper wiring prevents electrical noise.

Electrical noise can produce undesirable effects on electronic control circuits, which affects controllability. Electrical noise is generated by electrical equipment such as inductive loads, electric motors, solenoid coils, welding machinery, or fluorescent light circuits. The electrical noise or interference generated from these sources (and the effect on controllers) is difficult to define, but the most common symptoms are erratic control or intermittent operational problems.

## Important:

- For maximum EMC (electromagnetic compatibility) effectiveness, wire all humidity, high limit, and airflow controls using multicolored shielded/screened plenum-rated cable with a drain wire for the shield/screen. Connect the drain wire to the shield/screen ground terminal with wire less than 2" (50 mm) in length.
- Do not ground shield at the device end.

---

## WARNING!

Only qualified electrical personnel should perform field wiring installation procedures. Improper wiring or contact with energized circuits can cause property damage, severe personal injury, or death as a result of electric shock and/or fire.

---

---

## WARNING!

Do not remove the humidifier electrical panel cover or the heater terminal cover until electrical power is disconnected. Contact with energized circuits can cause property damage, severe personal injury, or death as a result of electrical shock.

---

## Vapormist wiring, continued

### WARNING!

DRI-STEEM strongly recommends installing a duct airflow proving switch and a duct high limit humidistat. These devices prevent a humidifier from making steam when there is low airflow in the duct or when the RH level in the duct is too high. Failure to install these devices can result in excessive moisture in the duct, which can cause bacteria and mold growth or dripping through the duct.

**Figure 12-2:**  
Field wiring requirements

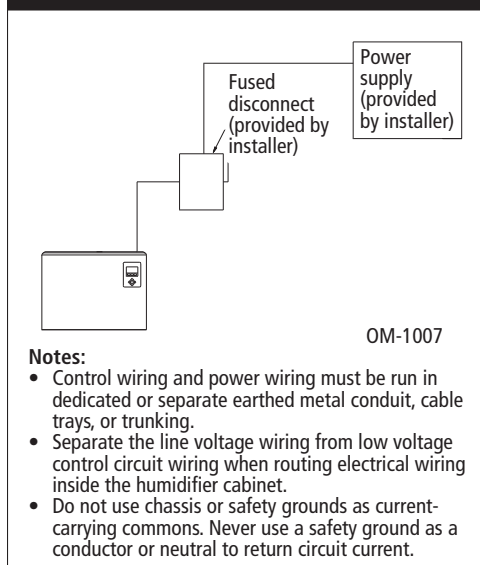

**Figure 12-1:**  
Shielded/screened cable drain wire connection to lug

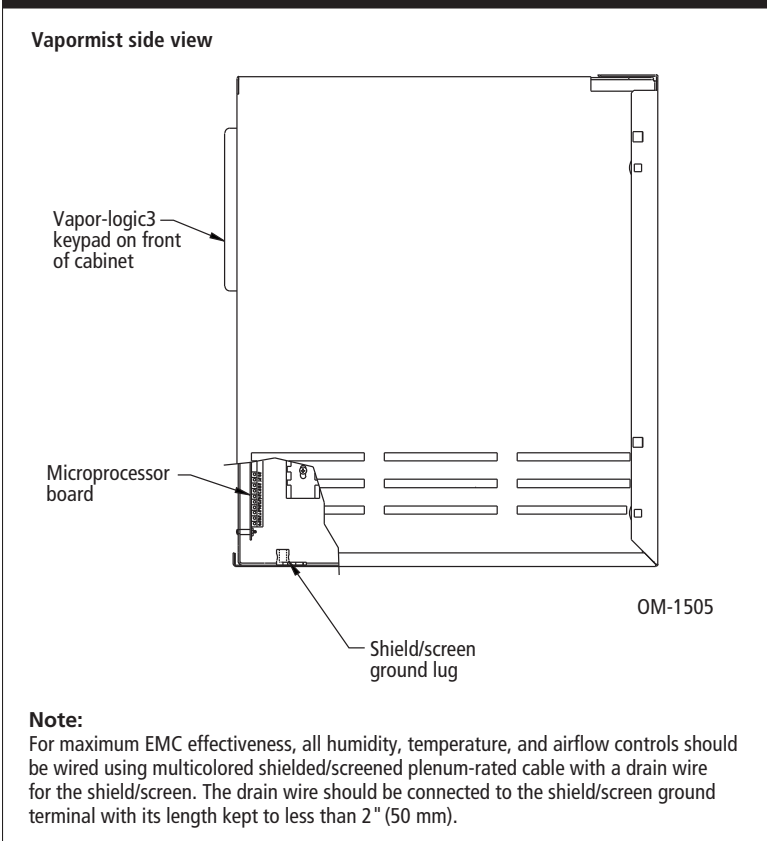

# Humidistat and transmitter placement

## Humidistat and transmitter locations are critical

Humidistat and humidity transmitter locations have a significant impact on humidifier performance. DRI-STEEM recommends that you do not interchange duct and room humidity devices. Room humidity devices are calibrated with zero or little airflow; whereas duct humidity devices require air passing across them. See the following recommendations and the locations in Figure 13-1.

- A Ideal humidistat or humidity transmitter location. Placement here ensures the best uniform mix of dry and moist air with stable temperature control.
- B Acceptable, but the room environment can affect controllability such as when the humidistat or transmitter is too close to air grilles, registers, or heat radiation from room lighting.
- C Acceptable, because this location provides a uniform mixture of dry and moist air. If there is a time lag between humidity generation and sensing, extend the sampling time.
- D Acceptable behind a wall or partition for sampling the entire room, if the sensor is near an air exhaust return outlet. Typical humidistat or transmitter placement for sampling a critical area.
- E Not acceptable, because these locations may not represent actual overall conditions in the space.
- F Not acceptable. Do not place humidistats or transmitters near windows, door passageways, or areas of stagnant airflow.
- G Best sensing location for a high limit humidistat or humidity transmitter and airflow proving switch.

**Figure 13-1:**  
**Recommended humidistat and transmitter locations**

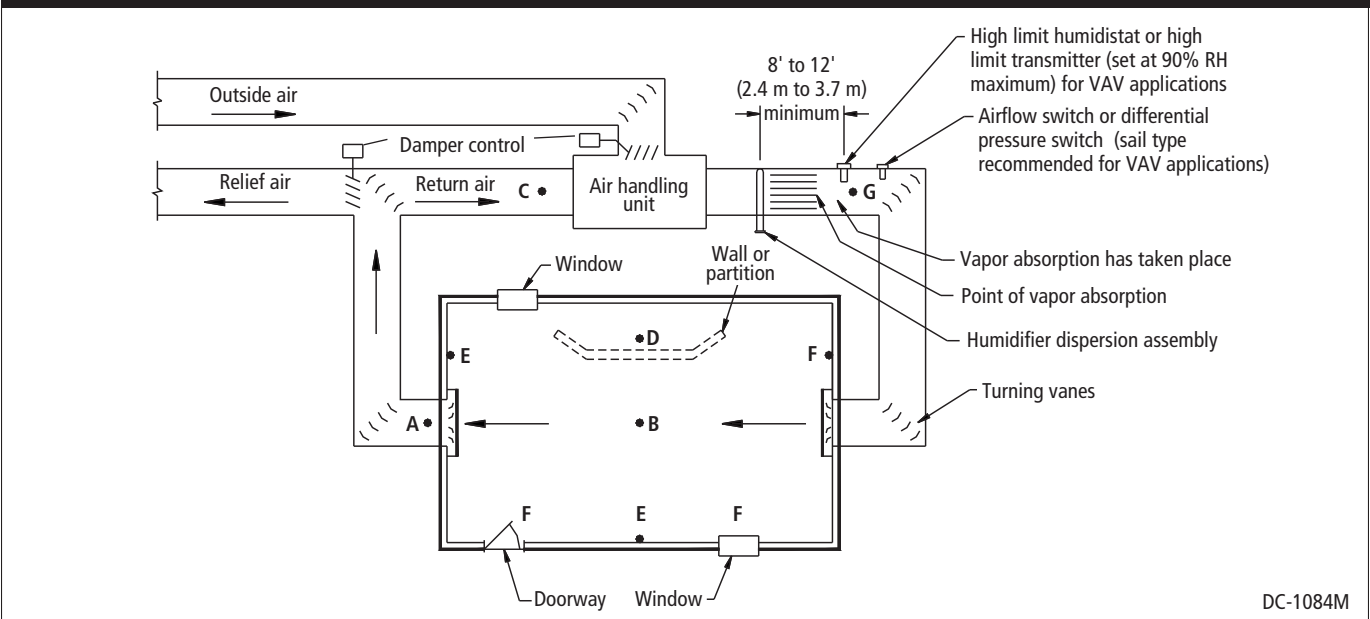

DC-1084M

mc\_060508\_0750

# Dispersion: General instructions

## Four places to find more information about dispersion

### 1. In this document:

- Interconnecting piping and drip tee installation, pages 15-17
- SDU-I and SDU-E (space distribution units) information, pages 18-21
- Single tube installation instructions, pages 22-23
- Rapid-sorb® installation instructions, pages 24-30

### 2. On our web site:

The following documents can be viewed, printed, or ordered from our web site, [www.dristeem.com](http://www.dristeem.com)

- Catalogs (include dispersion non-wetting distance graphs):
  - Vapormist
  - Ultra-sorb®
- Installation, Operation, and Maintenance manuals:
  - Ultra-sorb
  - Vapor-logic3 (includes information about sensors, and troubleshooting information)
- *DRI-STEEM Design Guide* (includes steam loss tables and general humidification information)

### 3. On Dri-calc:

Dri-calc® is our humidification system sizing and selection software, and can be ordered at our web site, [www.dristeem.com](http://www.dristeem.com). Included in Dri-calc:

- A comprehensive library of installation guide documents, including:
  - Rapid-sorb installation instructions for vertical airflows
  - Recommended dispersion placement within a duct or air handler
  - Recommended sensor placement

### 4. Or call us at 800-328-4447

While obtaining documents from our web site or from Dri-calc is the quickest way to review our literature, we'd also be happy to mail to you any literature you need.

## Selecting the dispersion assembly location

- Vapormist humidifiers operate with several types of dispersion assemblies: Space Distribution Units (SDUs), installed in open rooms; and single tube, multiple tube, Rapid-sorb, and Ultra-sorb assemblies, installed in ducts or air handling units
- For each dispersion assembly, DRI-STEEM documents distances required for absorption to occur. If you have questions about absorption distances, see the non-wetting tables in the Vapormist catalog, available for viewing, printing or ordering at [www.dristeem.com](http://www.dristeem.com)
- It is important that the dispersion assembly be positioned where the water vapor being discharged is carried off with the airstream and is absorbed before it can cause condensation or dripping in the duct.
- In general, the dispersion assembly is best placed where the air can most readily absorb the moisture being added without causing condensation at or after the unit. This normally will be after the heating coil or where the air temperature is highest.
- Place the dispersion assembly such that absorption will occur before the intake of a high efficiency filter. The filter can remove the visible moisture and become waterlogged.
- Place the dispersion assembly such that absorption will occur before coming in contact with any metal surface.
- Place the dispersion assembly such that absorption will occur before fire or smoke detection devices.
- Place the dispersion assembly such that absorption will occur before a split in the duct. Otherwise, the dispersion assembly can direct more moisture into one duct than the other.
- When draining dispersion condensate to an open drain, provide a 1" (25 mm) gap between the condensate drain piping and the drain. Locate air gap only in spaces with adequate temperature and air movement to absorb flash steam; otherwise, condensation may form on nearby surfaces.



## Dispersion: Interconnecting piping requirements

### Connecting humidifier to dispersion assembly with vapor hose

- Always support vapor hose to prevent sags or low spots and to maintain a minimum pitch of 2"/ft (15%) back to the humidifier.
- See the maximum steam carrying capacity table on the next page.
- Use DRI-STEEM vapor hose. Other manufacturers of vapor hose may use unacceptable release agents or material mixes that can affect humidifier system performance adversely. Using hose from alternative manufacturers increases the possibility of tank foaming and accelerated aging. Foaming causes condensate discharge at the dispersion assembly.
- Do not use vapor hose in outdoor applications.
- Do not insulate vapor hose. Insulation causes accelerated heat aging, causing the vapor hose to become hard and susceptible to failure due to cracks.
- The steam outlet on the humidifier is sized to the output of the humidifier. DO NOT use hose with an inside diameter (ID) smaller than the humidifier steam outlet.
- If the humidifier must be located above the dispersion assembly, use the recommend installation as shown on Page 17.
- For single tube applications, see the hose kit sizing chart on Page 22.

### Connecting humidifier to dispersion assembly with tubing or pipe

- See the following pages for interconnecting tubing and pipe pitch requirements for specific applications.
- The steam outlet on the humidifier is sized to the output of the humidifier. DO NOT use interconnecting tubing or pipe with an inside diameter (ID) smaller than the humidifier steam outlet.
- Steam supply adapters are available from DRI-STEEM. These adapters convert a tubing outlet on the humidifier to threaded pipe, allowing a pipe connection.
- 90° elbows are not recommended; use two 45° elbows, 1' (0.3 m) apart.
- Thin wall tubing heats up faster and causes less start-up loss than heavy wall pipe.

More on the next page ►

### Important:

Failure to follow the recommendations in this section can result in excessive back pressures on the humidifier. This will result in unacceptable humidification system performance such as leaking gaskets, blown water seals, erratic water level control, and spitting condensate from the dispersion tube(s).

### Important:

Reducing the inside diameter of the interconnecting piping will result in the internal humidifier system pressure exceeding the parameters for acceptable performance.

## Dispersion: Interconnecting piping requirements, continued

### Connecting humidifier to dispersion assembly with tubing or pipe (continued)

- Insulating hard pipe reduces the loss in output caused by condensation.
- When using hard pipe, take care to remove ALL traces of lubricants used to thread the pipe. This will minimize the possibility of tank foaming. Denatured alcohol or mineral spirits work best for removing lubricant.
- If the humidifier must be located above the dispersion assembly, use the recommend installation as shown on Page 17.
- See the maximum steam carrying capacity table below.

**Table 16-1:  
Maximum steam carrying capacity and length of interconnecting vapor hose, tubing and pipe\***

Vapor hose						Copper or stainless steel tubing and Schedule 40 steel pipe					
Hose I.D.		Maximum capacity		Maximum length**		Tube or pipe size***		Maximum capacity		Maximum developed length†	
inches	DN	lbs/hr	kg/h	ft	m	inches	DN	lbs/hr	kg/h	ft	m
1½	40	150	68	10	3	1½	40	150	68	20	6.1
2	50	250	113	10	3	2	50	220	100	30	9.2

**Notes:**

- \* Based on total maximum pressure drop in hose, tubing or piping of 5" wc (1250 Pa)
- \*\* Maximum recommended length for vapor hose is 10' (3 m). Longer distances can cause kinking or low spots.
- \*\*\* To minimize loss of capacity and efficiency, insulate tubing and piping.
- † Developed length equals measured length plus 50% of measured length, to account for pipe fittings.

# Dispersion: Drip tee installation

## Drip tee installation

Install a drip tee as shown below when the humidifier is mounted higher than the dispersion assembly, when interconnecting hose or piping needs to go over an obstruction, or when interconnecting piping runs are long.

**Important:** Vapor hose must be supported to prevent sagging or low spots.

## WARNING!

Dispersion tube, vapor hose, tubing, or hard pipe can contain steam, and surfaces can be hot. Discharged steam is not visible. Contact with hot surfaces or air into which steam has been discharged can cause severe personal injury.

**Figure 17-1:**  
**Drip tee installation**

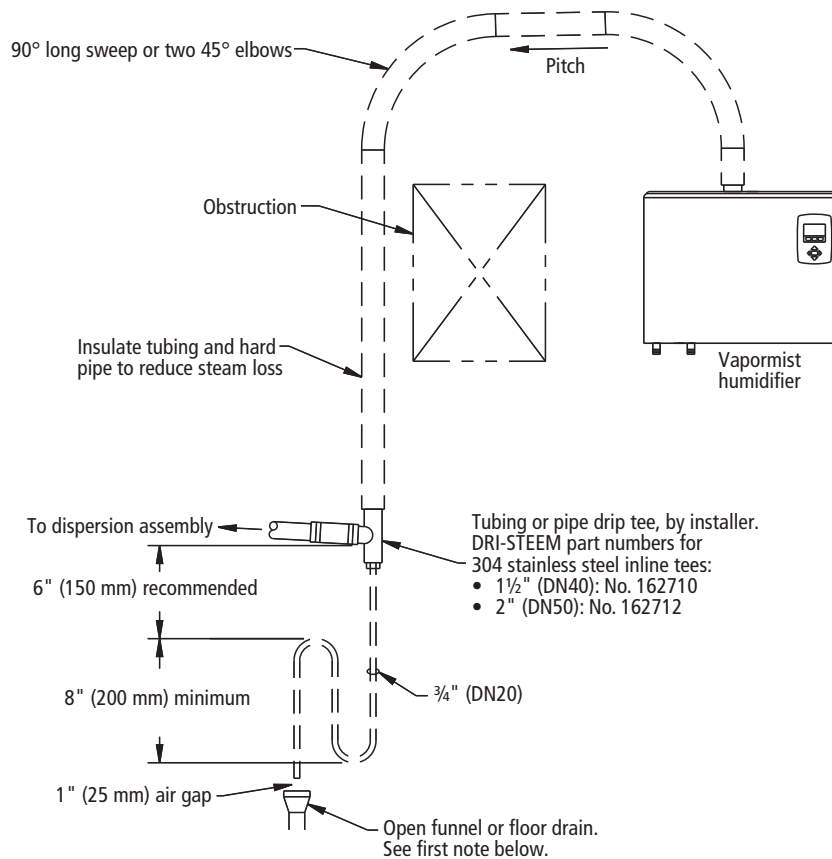

DC-1450

### Notes:

- Locate air gap only in spaces with adequate temperature and air movement to absorb flash steam; otherwise, condensation may form on nearby surfaces. Refer to governing codes for drain pipe size and maximum discharge water temperature.
- Support vapor hose so there are no sags or low spots.
- Dashed lines indicate provided by installer.

## Dispersion: SDU-I and SDU-E

**Figure 18-1:**  
SDU mounted directly above  
the Vapormist

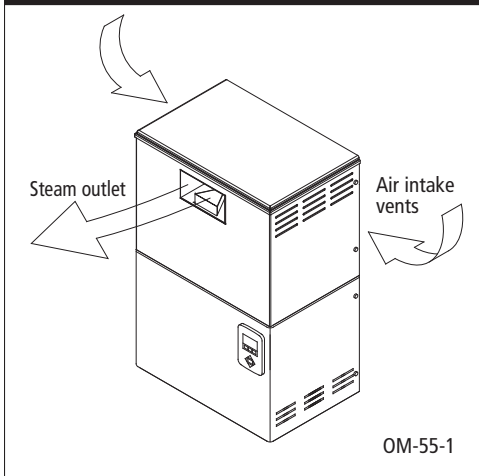

**Figure 18-2:**  
SDU mounted remotely from  
the Vapormist

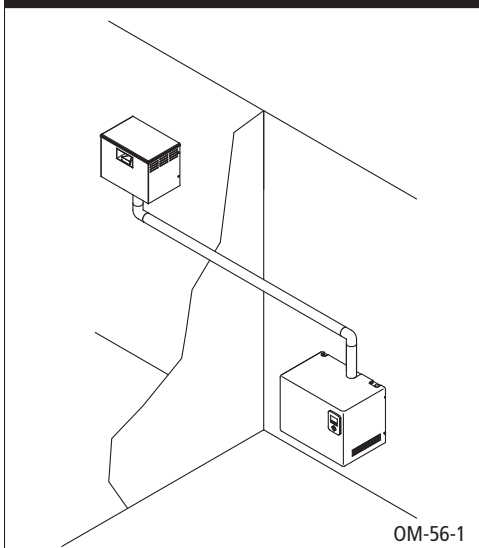

### SDU-I:

#### Provides instant, internal absorption

The Space Distribution Unit Internal Absorption (SDU-I) disperses humidity with no visible vapor trail or wetness, making the Vapormist with an SDU-I ideal for use in finished spaces. When room RH is 45% or less, the SDU-I fan mixes room air and steam to ensure complete absorption before discharge as humidified air. The SDU-I is available for models VM-2 through VM-8, and all VM-10 models except those using 240 V, three-phase power with SSR control.

### SDU-E:

#### For higher capacity units

The Space Distribution Unit External Absorption (SDU-E) is designed for higher capacity dispersion. The SDU-E is available for all Vapormist models except those models using 240V/480V/600V/ three-phase power with the SSR control option and drawing more than 21.7 amps. The SDU-E dispersion box requires an installed condensate drain line and water seal, provided by installer. See the following pages for installation instructions.

### Mounting the SDU-I and SDU-E

Both SDUs can be mounted on a wall directly above the Vapormist cabinet or mounted on a wall remote from the Vapormist. Use the mounting template on the box for correct placement. Two lag bolts are provided with each fan unit.

**Note:** See the following pages for more information about SDU-I and SDU-E.

**Figure 18-3:**  
SDU field wiring

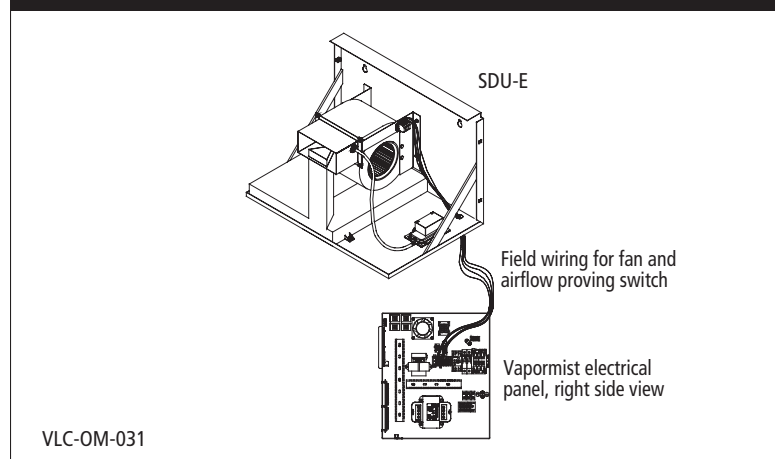

# Dispersion: SDU-I and SDU-E, continued

## Installing Space Distribution Units (SDUs)

Provide at least 6" (150 mm) clearance on each side of the SDU.

Field wiring is required to connect the SDU fan and airflow proving switch terminals to Vapormist electrical panel terminals. Refer to the external connections diagram in the package shipped with your unit.

## When performing Vapormist maintenance

If the SDU-E or SDU-I is installed immediately above the Vapormist, disconnect both hose clamps on the steam hose, grip the hose and rotate it to break it loose from the tubing, and then slide the hose up onto the SDU steam tube until sufficient clearance is provided to move the tank.

**Important:** Maximum ambient RH must not exceed 45% for the SDU-I to operate properly.

**Figure 19-1: SDU-I mechanical detail**

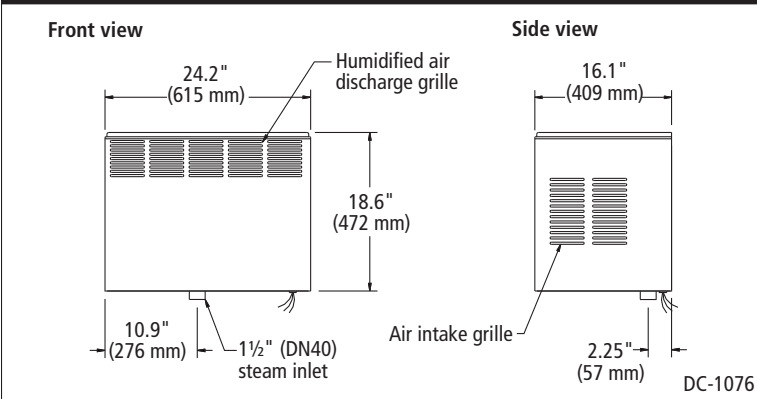

**Figure 19-2: SDU-E mechanical detail**

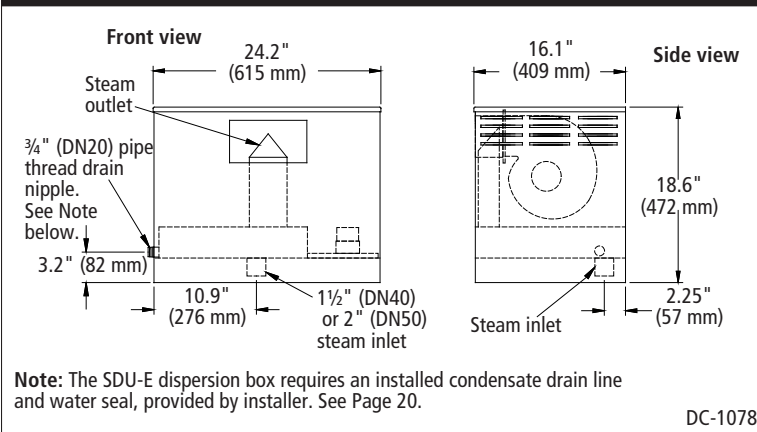
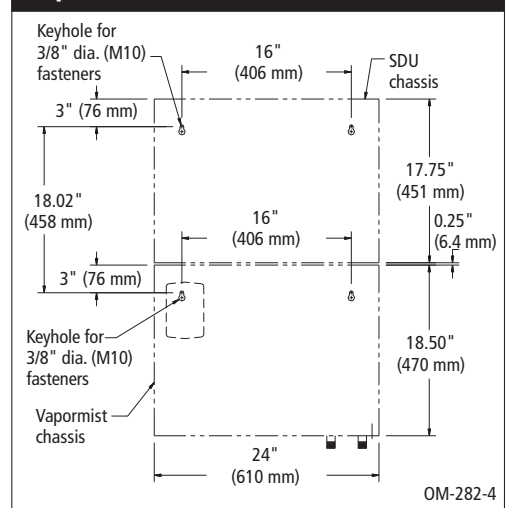

**Table 19-1: SDU specifications**

		SDU-I	SDU-E
Amps at 120V (50/60 Hz)		3.20	2.07
Horsepower		1/5	1/8
Airflow	cfm	760	545
	m <sup>3</sup> /s	0.36	0.26
dB*		58	64

**Note:**  
\* Measurement taken 6.5' (2 m) in front of SDU cabinet.

**Figure 19-3: Vapormist with an SDU-I**



**Figure 19-4: Vapormist with an SDU-E**

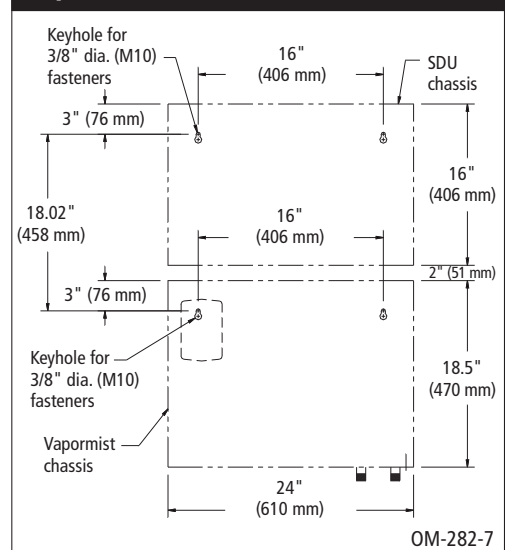

## Dispersion: SDU-I and SDU-E, continued

### WARNING!

If standing water is allowed to accumulate in the dispersion box:

- It can cause bacteria and mold growth which can cause illness.
- It can affect SDU-E fan unit performance and can cause hot water at 212 °F (100 °C) to discharge from the SDU-E fan unit, which can cause severe personal injury.

### Condensate drain connection to SDU-E fan unit

1. Piping must be minimum  $\frac{3}{4}$ " I.D. (DN20) and rated for 212 °F (100 °C) minimum continuous operating temperature.
  2. Drain line must be piped as shown in the drawing below. Provide a 6" (152 mm) drop prior to a 4" (102 mm) water seal to:
    - Ensure drainage of condensate from the dispersion box
    - Keep steam from blowing out of the drain line
  3. After the water seal, run the drain line to an open drain with a 1" (25 mm) vertical air gap. Cut the drain line at a 45 degree angle on the end above the drain to permit a direct stream of water into the drain pipe while maintaining a 1" (25 mm) air gap.
  4. All drain lines must be installed and sized according to governing codes.
  5. The drain line should have a union installed directly on the dispersion box  $\frac{3}{4}$ " (DN20) nipple to accommodate future removal of the SDU-E shroud.
  6. A drain line and water seal must be connected to the SDU-E fan unit dispersion box  $\frac{3}{4}$ " (DN20) nipple.
- Important:** If condensate is not drained from the dispersion box, standing water will accumulate.
7. The dispersion box is constructed with a pitch toward the drain; however, the SDU-E frame must be installed plumb and level for the dispersion box to drain properly.

**Figure 20-1:**  
SDU-E drain line piping

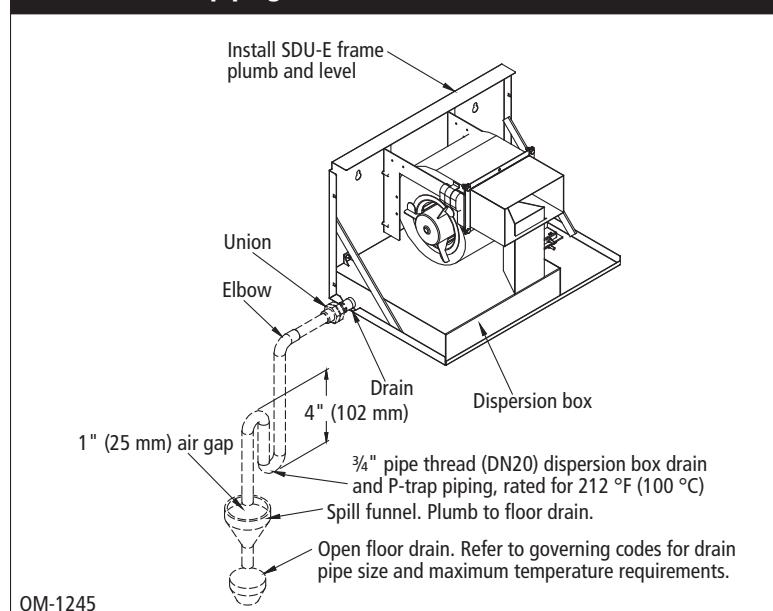

## Dispersion: SDU-E rise, throw, and spread

As steam is discharged from the SDU-E, it quickly cools and turns to a visible fog that is lighter than air. As this fog is carried away from the SDU-E by the airstream, it tends to rise toward the ceiling. If this fog contacts solid surfaces (columns, beams, ceiling, pipes, etc.) before it disappears, it could collect and drip as water. The greater the space relative humidity, the more the fog will rise, throw and spread.

The table below lists the minimum rise, throw and spread non-wetting distances for SDU-E area-type humidifiers at 40%, 50% and 60% RH in the space. Surfaces cooler than ambient temperature, or objects located within this minimum dimension, can cause condensation and dripping. To avoid steam impingement on surrounding areas, observe the minimum non-wetting distances in the table below.

The SDU-E contains a 545 cfm (0.26 m<sup>3</sup>/s) blower (120 V, single-phase, 60 Hz) and an airflow proving switch field-wired to the Vapormist humidifier electrical panel. A wiring diagram of the SDU-E is included with the unit.

On a call for humidity, the humidifier begins producing steam and the start relay energizes the SDU-E blower. When the call for humidity is satisfied, the Vapor-logic3 microprocessor keeps the blower running to disperse residual moisture using a time delay.

**Figure 21-1:**  
SDU-E: Rise, throw and spread

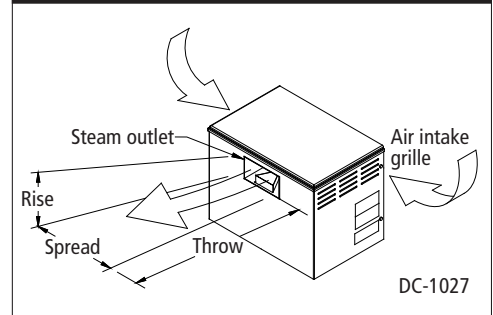

**Table 21-1:**  
SDU-E minimum non-wetting distances

Model	40% RH @ 70 °F (21 °C)						50% RH @ 70 °F (21 °C)						60% RH @ 70 °F (21 °C)					
	Rise		Throw		Spread		Rise		Throw		Spread		Rise		Throw		Spread	
	ft	m	ft	m	ft	m	ft	m	ft	m	ft	m	ft	m	ft	m	ft	m
VM-2	1.0	0.3	5.0	1.5	1.0	0.3	1.5	0.5	6.5	2.0	1.5	0.5	2.5	0.8	7.5	2.3	2.5	0.8
VM-4	1.0	0.3	5.0	1.5	1.0	0.3	1.5	0.5	6.5	2.0	1.5	0.5	2.5	0.8	7.5	2.3	2.5	0.8
VM-6	1.0	0.3	5.0	1.5	1.0	0.3	1.5	0.5	6.5	2.0	1.5	0.5	2.5	0.8	7.5	2.3	2.5	0.8
VM-8	1.0	0.3	5.5	1.7	1.0	0.3	1.5	0.5	6.5	2.0	1.5	0.5	2.5	0.8	7.5	2.3	2.5	0.8
VM-10	1.5	0.5	6.0	1.8	1.5	0.5	2.0	0.6	7.0	2.1	2.0	0.6	3.0	1.0	8.0	2.5	3.0	1.0
VM-12	1.5	0.5	6.0	1.8	1.5	0.5	2.0	0.6	7.0	2.1	2.0	0.6	3.0	1.0	8.0	2.5	3.0	1.0
VM-14	2.0	0.6	7.0	2.1	2.0	0.6	2.0	0.6	7.0	2.1	2.0	0.6	3.0	1.0	9.0	2.7	3.0	1.0
VM-16	2.0	0.6	7.0	2.1	2.0	0.6	2.0	0.6	7.0	2.1	2.0	0.6	3.0	1.0	9.0	2.7	3.0	1.0
VM-21	2.0	0.6	7.5	2.3	2.0	0.6	2.5	0.8	10.0	3.0	2.5	0.8	3.0	1.0	12.0	3.7	3.0	1.0
VM-25	2.0	0.6	8.0	2.5	2.0	0.6	2.5	0.8	10.5	3.2	2.5	0.8	3.5	1.1	12.5	3.8	3.5	1.1
VM-30	2.0	0.6	8.0	2.5	2.0	0.6	2.5	0.8	10.5	3.2	2.5	0.8	3.5	1.1	12.5	3.8	3.5	1.1
VM-34	2.0	0.6	8.0	2.5	2.0	0.6	2.5	0.8	10.5	3.2	2.5	0.8	3.5	1.1	12.5	3.8	3.5	1.1

**Notes:**

- Rise: Minimum non-wetting height above the steam outlet of the SDU-E
- Throw: Minimum non-wetting horizontal distance from the steam outlet of the SDU-E.
- Spread: Minimum non-wetting width from the steam outlet of the SDU-E.

## Dispersion: Single tube

**Figure 22-1:**  
Single tube without condensate drain

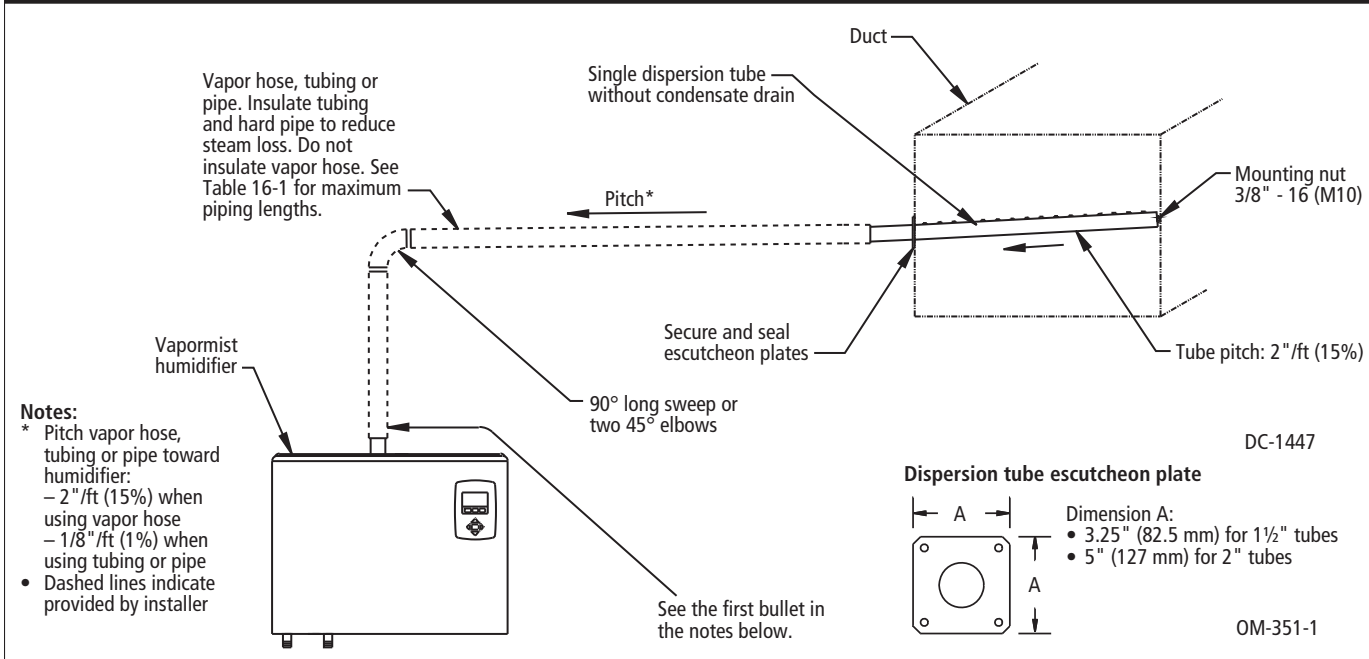

**Table 22-1:**  
Hose kit sizing by model

Humidifier models	Hose kit (vapor hose, dispersion tube and hardware)	Maximum capacity of dispersion tube	
		lbs/hr	kg/h
VM 2-8	1½" (DN40) hose kit without drain	28.4	13
VM 10-16	1½" (DN40) hose kit with drain	56.8	25.8
	2" (DN50) hose kit without drain	56.8	25.8
VM 21-25	2" (DN50) hose kit without drain	85.2	38.6
VM 30-34	These models require multiple tube assemblies and cannot use a hose kit.		

### WARNING!

Dispersion tube, vapor hose, tubing, or hard pipe can contain steam, and surfaces can be hot. Discharged steam is not visible. Contact with hot surfaces or air into which steam has been discharged can cause severe personal injury.

### Notes:

- Use DRI-STEEM's hard pipe adapter kit to connect the steam outlet to hard pipe. Use a hose clamp to connect the steam outlet to vapor hose. Use a hose cuff and clamps to connect the steam outlet to tubing.
- Thin-walled tubing heats up faster than heavy-walled pipe causing less steam loss at start-up.
- Hard pipe or tubing diameter must match Vapormist steam outlet size 1½" (DN40) or 2" (DN50).
- See the Maximum Steam Carrying Capacity and Steam Loss tables on Page 16.
- Maximum capacity of dispersion tube (without condensate drain):
  - 1½" (DN40): 28.4 lbs/hr (13 kg/h)
  - 2" (DN50): 56.8 lbs/hr (25.8 kg/h)
- Orient dispersion tube so that tubelets (steam orifices) point up.
- When mounting the humidifier above the level of dispersion tube, see the drawing on Page 17.
- Failure to follow the recommendations on this page can result in excessive back pressures on the humidifier. This can lead to dispersion tube(s) spitting, steam blowing through water seals, or leaking gaskets.
- Table 22-1 shows hose kit sizes by humidifier model. A hose kit includes vapor hose, a dispersion tube and hardware. Note that the capacities of models VM-30 and VM-34 require multiple tube assemblies and therefore cannot use a hose kit. For multiple tube assemblies, see information on Rapid-sorb on pages 24-30.



# Dispersion: Single tube, continued

**Figure 23-1:**  
Single tube with condensate drain

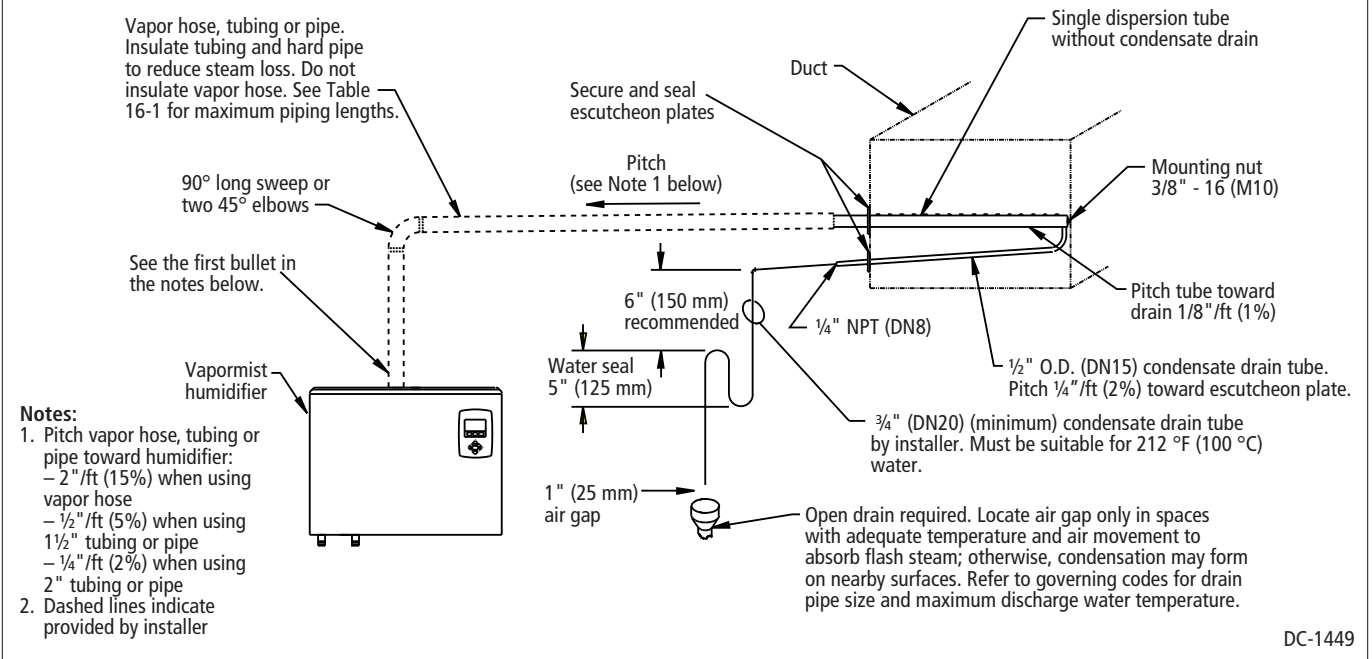

**Notes:**

- Use DRI-STEEM’s hard pipe adapter kit to connect the steam outlet to hard pipe. Use a hose clamp to connect the steam outlet to vapor hose. Use a hose cuff and clamps to connect the steam outlet to tubing.
- Thin-walled tubing heats up faster than heavy-walled pipe causing less steam loss at start-up.
- Hard pipe or tubing diameter must match Vapormist steam outlet size 1½" (DN40) or 2" (DN50).
- See the Maximum Steam Carrying Capacity and Steam Loss tables on Page 16.
- Maximum capacity of dispersion tube with condensate drain:
  - 1½" (DN40): 56.8 lbs/hr (25.8 kg/h)
  - 2" (DN50): 85.2 lbs/hr (38.6 kg/h)
- Orient dispersion tube so that tubelets (steam orifices) point up.
- When mounting the humidifier above the level of dispersion tube, see the drawing on Page 17.
- Failure to follow the recommendations on this page can result in excessive back pressures on the humidifier. This can lead to dispersion tube(s) spitting, steam blowing through water seals, or leaking gaskets.
- See the Hose Kit Sizing table on the previous page.

**Figure 23-2:**  
Escutcheon plates

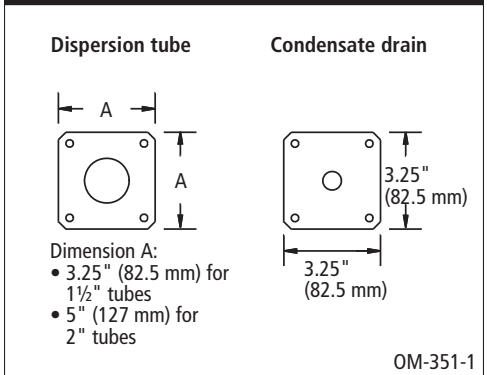

**WARNING!**

Dispersion tube, vapor hose, tubing, or hard pipe can contain steam, and surfaces can be hot. Discharged steam is not visible. Contact with hot surfaces or air into which steam has been discharged can cause severe personal injury.

## Dispersion: Rapid-sorb

### Important:

Failure to follow the recommendations in this section can result in excessive back pressures on the humidifier. This will result in unacceptable humidification system performance such as leaking gaskets, blown water seals, erratic water level control, and spitting condensate from the dispersion tube(s).

**Table 24-1:**  
Rapid-sorb dispersion tube capacities

Tube capacity		Tube diameter	
lbs/hr	kg/h	inches	DN
≤ 35	≤ 16	1½	40
36-70	17-32	2	50

**Table 24-2:**  
Rapid-sorb header capacities

Header capacity		Header diameter	
lbs/hr	kg/h	inches	DN
≤ 250	≤ 113	2	50
251-500	114-227	3	80
501-800	228-363	4	100

### General Rapid-sorb installation instructions

- Before you begin installation, read all dispersion instructions in this manual.
- Before you begin installation, unpack shipment and verify receipt of all Rapid-sorb components with packing list. Report any shortages to DRI-STEEM factory immediately. The components typically include the following:
  - Multiple dispersion tubes
  - Header
  - ¾" × 2" (19 mm × 51 mm) L-bracket
  - A single duct escutcheon plate the size of the header
  - Slip couplings or hose cuffs and clamps.
  - Accessories such as duct plates, slip couplings, or hose cuffs are in a plastic bag.
  - The bolts and washers for mounting the dispersion tubes to the bracket will be in the end of the tubes or packaged in a bag with the other accessories.
  - The tubes, header, and L-bracket are tagged with the customer requested identification number written on each component.
- When choosing a location for installation, select a location that provides necessary access in and around the ductwork or air handler.
- The Rapid-sorb typically is installed centered side to side in a duct, or is installed across the face of a coil in an air handler.
- The center line of the outer dispersion tubes should never be closer than 4.5" (114 mm) from the side of the ductwork or air handler wall.
- Rapid-sorbs are provided with an L-bracket for installation:
  - L-brackets that are 50" (1270 mm) or less in length have a hole 4" (102 mm) in from each end to mount the L-bracket to the duct or air handler wall.
  - L-brackets that are greater than 50" (1270 mm) in length have an additional hole in the center of the L-bracket.
  - **Important:** Before marking and drilling holes in the duct or air handler, refer to ALL pitch requirements for the Rapid-sorb assembly you received (see the table on the next page). The size, quantity, and location of penetrations are determined by the specific dimensions and configuration of the Rapid-sorb assembly you received.
  - **Note:** The hardware for mounting the L-bracket to the duct or air handler wall and the hardware for the header support bracket is not provided.
- The Rapid-sorb instructions that follow are for the most typical Rapid-sorb installations — installed in a duct horizontal airflow with Rapid-sorb header either inside or outside the duct. See the Dri-calc Installation Guides library or contact your representative/distributor or DRI-STEEM for installation instructions for air handler or vertical airflow applications.

## Dispersion: Rapid-sorb, continued

### Rapid-sorb pitch requirements

- When installing a Rapid-sorb with the header outside a horizontal airflow duct, consider the following pitch issues:
  - For 1½" (DN40) dispersion tubes use a fastener of sufficient length to accommodate the 1/8"/ft (1%) pitch requirements toward the ¾" pipe thread (DN20) header drain fitting.
  - For 2" (DN50) dispersion tubes, the bracket can be mounted flush to the ductwork. The 1/8"/ft (1%) pitch typically can be accomplished in the length of the hose cuffs used to connect the tubes to the header.
- See the table below and the drawings on the following pages for pitch requirements.

**Table 25-1:  
Pitch of interconnecting piping, dispersion tubes, and headers for Rapid-sorb evaporative dispersion units**

Airflow	Type of interconnecting piping	Diameter of interconnecting piping	Pitch of interconnecting piping	Pitch of dispersion tubes	Pitch of header
Horizontal	Vapor hose	1½" (DN40) 2" (DN50)	2"/ft (15%) toward Rapid-sorb	Vertically plumb	1/8"/ft (1%) toward condensate drain
	Tubing or pipe	1½" (DN40) 2" (DN50)	1/8"/ft (1%) toward Rapid-sorb		
Vertical	Vapor hose	1½" (DN40) 2" (DN50)	2"/ft (15%) toward Rapid-sorb	2"/ft toward header	1/8"/ft (1%) toward condensate drain
	Tubing or pipe	1½" (DN40) 2" (DN50)	1/8"/ft (1%) toward Rapid-sorb		

## Dispersion: Rapid-sorb, continued

**Figure 26-1:**  
Rapid-sorb dispersion assembly

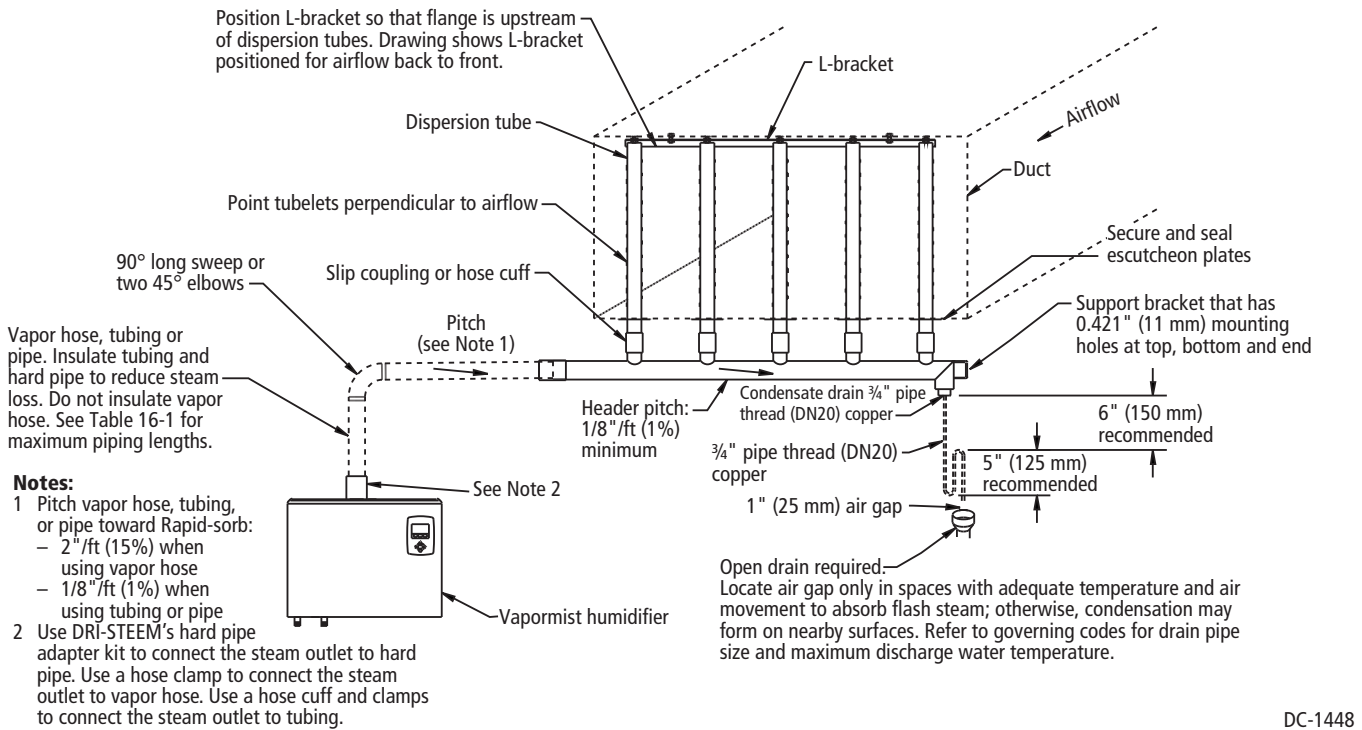

**Figure 26-2:**  
Dispersion tube escutcheon plates

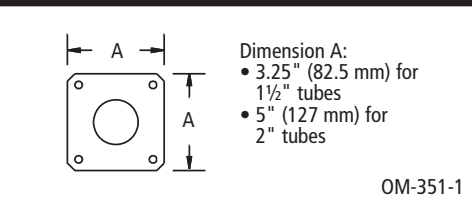

### WARNING!

Dispersion tube, vapor hose, tubing, or hard pipe can contain steam, and surfaces can be hot. Discharged steam is not visible. Contact with hot surfaces or air into which steam has been discharged can cause severe personal injury.

### Assembly and installation instructions for a Rapid-sorb installed with header outside the duct (horizontal airflow)

1. Locate and cut the holes in the ductwork for the dispersion tubes. Use the L-bracket as a template to locate the holes on the duct floor.
2. Temporarily, loosely suspend or support the header below the final location — the vertical balance point of the dispersion tube length dictates where the header should be suspended or supported temporarily.
3. Mount the dispersion tubes to the header with the provided connector, either a slip coupling or a hose cuff.
  - When installing slip couplings for 1½" (DN40) dispersion tubes, take care not to shear the O-rings.
  - Set the slip coupling on the header stub or dispersion tube so the O-ring is resting on the face of the tubing.
  - Rotate the slip coupling as you push it on to the tubing.
  - The O-rings are lubricated at the factory. If additional lubrication is necessary, DO NOT use a petroleum-based lubricant.
4. Position the flange of the L-bracket so it is upstream of the tubes when the assembly is raised and fastened into position.

## Dispersion: Rapid-sorb, continued

Fasten the L-bracket to the end of the dispersion tubes with the provided bolt, lock washer, and flat washer.

5. Before tightening the L-bracket bolts to the dispersion tubes follow these instructions:
  - For 1½" (DN40) dispersion tubes:
    - The dispersion tube will rotate in the slip coupling. Verify that the dispersion tube orifices are directed perpendicular to the airflow.
    - The dispersion tube and slip coupling must be fully engaged on to the header stub for the O-rings to provide a seal.
  - For 2" (DN50) dispersion tubes:
    - Before securing the hose cuff in place with the hose clamps on the dispersion tube and the header stub, verify that the dispersion tube orifices are directed perpendicular to the airflow.
6. Slide the assembly up until the L-bracket aligns with the mounting holes in the duct.
  - For 1½" (DN40) dispersion tubes:
    - The header pitch is duplicated in the L-bracket.
    - The dispersion tube and slip coupling must be fully engaged on to the header stub for the O-rings to provide a seal.
    - The high end of the L-bracket can be fastened tight to the duct or air handler.
    - On the low end of the L-bracket, the fastener must be long enough to compensate for the pitch, and a nut should be provided and secured on both sides of the L-bracket and the duct or air handler for stability.
  - For 2" (DN50) dispersion tubes:
    - Fasten the bracket to the top of the duct and use the hose cuffs to compensate for the pitch of the header.
    - Before securing the hose cuff in place with the hose clamps on the dispersion tube and the header stub, verify that the header pitch, 1/8"/ft (1%) toward drain, is maintained.
7. Permanently secure both ends of the header and verify that the header pitch, 1/8"/ft (1%) toward drain, is maintained.
8. Verify that all fasteners are secure:
  - L-bracket to duct
  - Dispersion tubes to L-bracket
  - Hose clamps on 2" (DN50) tubes
9. Secure and seal the dispersion tube escutcheon plate and condensate drain tube escutcheon plate around the respective tubes, if applicable.

### Note:

See Page 30 for steam supply and condensate drain line connection instructions.

## Dispersion: Rapid-sorb, continued

**Figure 28-1:**  
**Rapid-sorb installed in a horizontal airflow with header inside the duct**

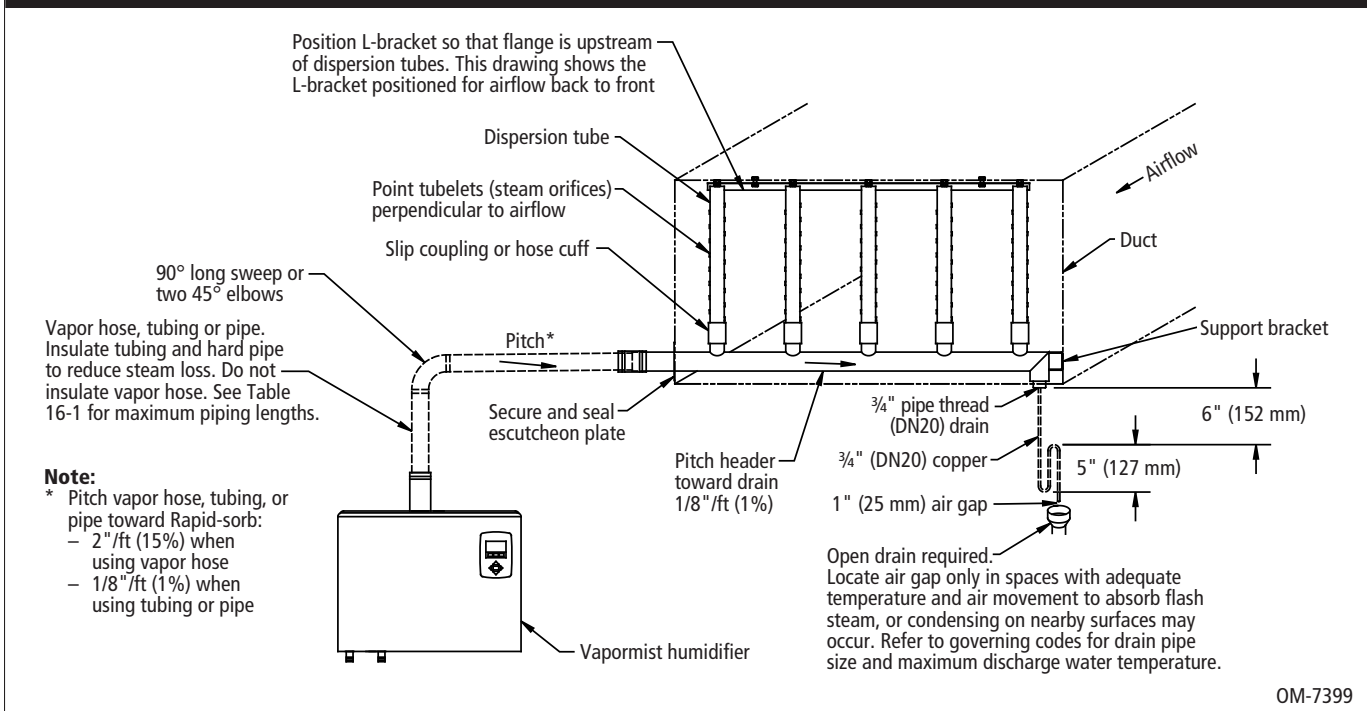

### WARNING!

Dispersion tube, vapor hose, tubing, or hard pipe can contain steam, and surfaces can be hot. Discharged steam is not visible. Contact with hot surfaces or air into which steam has been discharged can cause severe personal injury.

### Assembly and installation instructions for a Rapid-sorb installed with header inside the duct (horizontal airflow)

1. Locate and cut the holes in ductwork or air handler for steam header penetration, condensate drain piping, and header support bracket fastener. Allow 1/8"/ft (1%) header pitch toward the support bracket when you drill the hole for the header support bracket fastener.
2. Loosely fasten the header in place.
3. Rotate the header 90° so the header stubs point horizontally in the duct.
  - When installing in an air handler, the rotation of the header is often less than 90°. Typically, due to the condensate drain piping requirements, the header can be set on the floor of the air handler, assembled in the vertical position, and then raised and mounted in place.
4. Mount the dispersion tubes on the header with the slip couplings or hose cuffs.
  - When installing slip couplings for 1½" (DN40) dispersion tubes, take care not to shear the O-rings.
  - Set the slip coupling on the header stub or dispersion tube so the O-ring is resting on the face of the tubing.

More on next page ►

## Dispersion: Rapid-sorb, continued

- Rotate the slip coupling as you push it on to the tubing.
  - The O-rings are lubricated at the factory. If additional lubrication is necessary, DO NOT use a petroleum-based lubricant.
5. Allow the dispersion tubes to rest against the bottom of the duct.
  6. Position the flange of the L-bracket so it is upstream of the tubes when the assembly is rotated into position. Fasten the L-bracket to the end of the dispersion tubes with the provided bolt, lock washer, and flat washer.
  7. Rotate the assembly up until the L-bracket aligns with the mounting holes in the duct or air handler.
    - 1½" (DN40) dispersion tubes
      - The header pitch is duplicated in the L-bracket.
      - The dispersion tube and slip coupling must be fully engaged on to the header stub for the O-rings to provide a seal.
      - The high end of the L-bracket can be fastened tight to the duct or air handler.
      - On the low end of the L-bracket, the fastener must be long enough to compensate for the pitch, and a nut should be provided and secured on both sides of the L-bracket and the duct or air handler for stability.
    - 2" (DN50) dispersion tubes
      - Fasten the bracket to the top of the duct or air handler and use the hose cuffs to compensate for the pitch of the header.
      - Before securing the hose cuff in place, with the hose clamps on the dispersion tube and the header stub, verify that the dispersion tube orifices are directed perpendicular to the airflow.
  8. Verify that all fasteners are secure:
    - L-bracket to duct
    - Dispersion tubes to L-bracket
    - Hose clamps on 2" (DN50) tubes
    - Header support bracket fastener
  9. Secure and seal the header escutcheon plate around the header.
  10. See the next page for steam supply and condensate drain line connection instructions.

---

## Dispersion: Rapid-sorb, continued

### Steam supply connections to the Rapid-sorb header

1. Connect the steam supply interconnecting piping from the humidifier to the Rapid-sorb. The steam supply piping requires a minimum of 1/8"/ft (1%) pitch toward the header.
2. If multiple humidifiers are supplying one Rapid-sorb, a multiple steam supply connector is provided.
  - Typically, the multiple steam supply connector attaches to the Rapid-sorb header supply end with hose cuff and clamps.
  - Route the necessary number of steam supplies from the humidifier tanks to the steam supply connector.
  - Position the steam supply connector to accept the steam supplies while maintaining the necessary pitch.
  - Make sure the hose clamps on the steam supply connector and header are tight.

### Condensate drain connections to the Rapid-sorb header

1. Piping must be minimum 3/4" I.D. (DN20) and rated for 212 °F (100 °C) minimum continuous operating temperature.
2. Condensate drain line must be piped as shown in the figures on the previous pages. Provide a 6" (152 mm) drop prior to a 5" (127 mm) water seal to:
  - Ensure drainage of condensate from the header
  - Keep steam from blowing out of the drain line
3. After the water seal, run the drain line to an open drain with a 1" (25 mm) vertical air gap. Cut the drain line at a 45° angle on the end above the drain to permit a direct stream of water into the drain pipe while maintaining a 1" (25 mm) air gap. Locate air gap only in spaces with adequate temperature and air movement to absorb flash steam; otherwise, condensing on nearby surfaces may occur.
4. All drain lines must be installed and sized according to governing codes.



---

## Humidifier start-up procedure

After the system is installed and connected properly, you can begin start-up procedures.

1. Verify that the Vapormist humidifier, controls, piping, electrical connections, steam supply, and dispersion assembly(s) are installed according to the following:
  - Installation instructions in this manual
  - *Vapor-logic3 Installation and Operation Manual*
    - Installation section
    - Installation checklist
  - Ladder style wiring diagram (inside humidifier electrical panel cover)
  - External connections wiring diagram (inside humidifier electrical panel cover)
  - All governing codes
2. Verify that all electrical connections are secure before applying power. (See torque requirements on Page 35.)

---

### 3. WARNING!

Make sure that all electrical covers are in place and secure before turning on electrical power. These include the following:

- Heater terminal cover on tank
- Humidifier electrical panel cover

- 
4. Verify that the humidifier is mounted level and securely supported before filling with water (see the operating weights table in this manual).
  5. Verify that the humidifier is level front to back and side to side after it is full of water.
  6. Refer to the following sections in the *Vapor-logic3 Installation and Operation Manual*:
    - Operation section
    - Start-up checklist (it is critical that the installer follow this checklist)
  7. During start-up, do not leave the humidifier unattended.
  8. Monitor humidifier operation through multiple fill cycles. The humidifier operating status appears on the keypad/display.
  9. On standard water units, water skims from the humidifier after every fill cycle. Adjust the amount of skim by increasing or decreasing the skim time (see the *Vapor-logic3 Installation and Operation Manual*). However, at start-up, DRI-STEEM recommends initially running the humidifier with the factory default setting for skim time.

---

### WARNING!

Only qualified electrical personnel should perform start-up procedure.

Contact with energized circuits can cause property damage, severe personal injury or death as a result of electrical shock or fire.

---

**CAUTION!** In the event the humidifier tank does not contain water and the heaters are energized, turn main power off. Operation of the heaters without water will cause damage to the humidifier. Before turning main power on, verify that all wiring has been completed per the wiring instructions in this manual and the unit wiring diagrams.

#### Note:

The *Vapor-logic3 Installation and Operation Manual* is a comprehensive operation manual. Refer to it for information regarding the following features:

- Keypad display setup and menu information
- Control input signals and functions
- Drain, flush, and skim features
- Safety features
- Alarm screens and fault messages

The *Vapor-logic3* manual was shipped with your humidifier. Additional copies can be viewed, printed, or ordered at [www.dristeem.com](http://www.dristeem.com)

---

## Maintenance: Vapormist standard water models

---

### WARNING!

Do not remove the humidifier electrical panel cover or the heater terminal cover until electrical power is disconnected. Contact with energized circuits can cause property damage, severe personal injury or death as a result of electrical shock.

---

---

### WARNING!

Opening the drain valve when the tank is hot can discharge water with a temperature up to 212 °F (100 °C) into the plumbing system. This can cause damage to the plumbing system if the humidifier is not properly connected to a DRI-STEEM Drane-kooler.

Do not touch the tank or drain piping until the unit has had sufficient time to cool, or serious injury can occur.

---

### Vapormist standard water quality recommendations

The best way to determine how often your particular system needs maintenance is to remove the tank cover and inspect it for mineral deposits after three months of duty. Potable water carries a variety of minerals and other materials in a mix that varies from location to location. This variation in water quality, combined with the hours of operation and duty cycle, will determine your own unique maintenance schedule.

### Water quality makes a difference

- Light to moderately hard water (2 to 10 grains hardness per gallon [35 mg/L to 170 mg/L]) requires:
  - Annual cleaning
  - Regular skimming
- High mineral content water (more than 10 grains hardness per gallon [more than 170 mg/L]) requires:
  - Cleaning frequency determined by use and water quality
  - Regular skimming
  - Periodic drain and flush cycles
- Softened water, which dramatically reduces mineral accumulation inside the standard water models, requires:
  - Increased skim time
  - No drain and flush cycles(Note: Solids, like silica, are not removed in the softening process.)

### Adjusting skim duration

The skim time duration determines the quantity of water skimmed with each fill cycle. The skim time is field adjustable using the Vapor-logic3 keypad.

Each time the Vapormist refills, it fills to an elevation near the lip of the skim/overflow fitting. A portion of the refill water then flows to the drain carrying most of the minerals left by the previous evaporating cycle. This reduces the mineral concentration, thereby reducing the frequency of cleaning needed.

The heated water that flows to the drain is an operational cost. Cleaning the humidifier is also an operational cost. Therefore, DRI-STEEM recommends that the user observe and adjust the skimming quantity to achieve a balance between minimizing mineral buildup and conserving heated water.

More on the next page ►

## Maintenance: Vapormist standard water models, continued

### Cool down humidifier before beginning maintenance

Before performing any maintenance, allow the tank to cool down.

Note: Fresh make-up water is used to speed up cooling. Do not close the manual water supply before cooling down the humidifier; otherwise the tank could stay hot for several hours.

- Insulated and uninsulated tanks will have hot surfaces.
- Verify that there is no call for humidity and that the aquastat set point (adjusted using the keypad/display Setup screens) is less than room temperature (default setting is 40 °F [4 °C]) so that the heaters do not energize while cooling down the tank.
- For models with a standard drain valve:
  - Manually open the drain valve by moving the valve lever located on the back of the drain valve to the manual open position.
  - The fill valve eventually opens.
  - Let the fill water run until the tank is cooled; then shut off the field-installed manual supply water shut-off valve.
  - Let the tank drain; then manually close the drain valve.
- For models with optional drain valves:
  - For drain valves without the manual open lever, use the keypad to perform the cool down process.
  - Go to the control modes screen and select Manual Drain.
  - Allow approximately half the water to drain out of the tank.
  - In the Control Modes screen select Auto; the fill valve opens and the humidifier cools down.
  - When the fill valve closes, select Manual Drain in the Control Modes screen and let the tank drain dry. The humidifier should be cool enough to work on.
  - For more information about using the keypad, see the *Vapor-logic3 Installation and Operation Manual*.

mc\_052708\_1145

### Inspection and maintenance

1. **Annually** (also recommended when maintenance is performed)
  - Inspect tank and gaskets for leaks.
  - Measure current draw of heaters and verify amp values per stage by comparing to the wiring diagram located inside the subpanel cover. This identifies any burned out heaters. Only qualified electrical personnel should perform this task.
  - All safety devices in the control circuit should be cycled on and off to verify they are functioning. These include:
    - High limit switch
    - Airflow proving switch
    - Low water level probe. Pull out probe plug; fill valve should energize.

mc\_060208\_1005

**Figure 33-1:**  
Cover enclosure screw cap detail

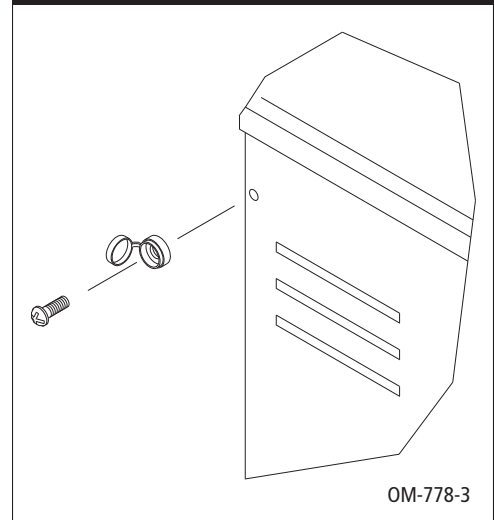

### Humidifier De-scaling Solution

Scale buildup on humidifier heaters acts as an insulator, reducing humidifier performance while increasing energy costs. To keep humidifiers operating as efficiently as possible, remove scale with DRI-STEEM's Humidifier De-scaling Solution, available for purchase from your DRI-STEEM representative or distributor.

The De-scaling Solution cleans without risk of corroding humidifier tanks or welds; and there is no off-gassing, flammability, or added heat risks associated with other cleaning solutions. The De-scaling Solution also cleans surfaces unreachable by hand scraping.

DRI-STEEM's Humidifier De-scaling Solution is the only approved cleaner/de-scaler for use with DRI-STEEM humidifiers. Use of other cleaners/de-scalers may void your DRI-STEEM warranty.

mc\_021908\_1410

More on the next page ►

---

## Maintenance: Vapormist standard water models, continued

### 2. Seasonally (or as required, depending on water quality)

- Remove the evaporating chamber
  - Remove the two fasteners on each side of the cover enclosure (see figure below)
  - Remove the enclosure.

---

### WARNING!

Do not remove the humidifier electrical panel cover or the heater terminal cover until electrical power is disconnected. Contact with energized circuits can cause property damage, severe personal injury or death as a result of electrical shock.

---

- If the Vapormist has an SDU mounted directly above it, the SDU cover must be removed before removing the humidifier cover.
- If the tank is hot, cool it down first (see instructions on Page 33).
- Shut off the water supply.
- Allow the tank to drain completely.
- Shut off the electrical supply.
- Disconnect the fill line at the supply side of the fill valve.
- Disconnect the electrical plugs between the tank components and the back of the electrical panel (includes: power plug, fill plug, drain plug, water level control plug, tank temperature sensor plug and thermal trip plug).  
**Important:** Disconnect by pulling on plug housing. Do not disconnect by pulling on cord or wires.
- Disconnect the drain union on the back left corner of the frame.
- Disconnect the steam supply hose from the top of the tank.
- Lift the tank foot above the frame flange and slide the tank assembly forward to remove.
- Loosen the four cover bolts and remove the cover assembly from the tank.
- Clean the tank interior using a putty knife or similar flat instrument.
- Unplug probe plug assembly. Leave ground wire connected to tank. Unscrew the probe rod assembly and clean the plastic probe housing, ensuring that all passageways are clear. Clean the probe rods using steel wool or a similar mild abrasive material. Inspect the composite plastic probe housing for any signs of cracking, roughness, or deterioration. If found, replace.

mc\_060208\_1055-2

More on the next page ►

## Maintenance: Vapormist standard water models, continued

- Install the probe and probe plug assembly. Verify ground wire is solidly connected to tank.
- Secure the chamber cover, making sure the cover gasket is seated and the chamber is sealed.
- Re-install the evaporating chamber.
  - Reconnect the fill line.
  - Reconnect the electrical plugs (plugs are color coded).
  - Reconnect the drain union.
  - Reconnect the vapor hose.
- Verify electrical connections.
  - Verify that all DIN rail-mounted components are securely fastened to DIN rail.
  - Verify that all power terminal screws and lugs are tight from power block to heaters. See the table at right for torque specifications.
  - Verify that all plugs located under the humidifier cover are completely plugged in.
- Move the drain valve lever back to the auto position.
- Turn on the water supply.
- Turn on the electrical power.

mc\_060208\_1055-2

### 3. Off-season maintenance

- Perform complete inspection and cleaning of the following:
  - Heaters
  - Probe rods
  - Skimmer port and water seal
  - Humidifier tank
- After cleaning, the humidifier should remain empty until humidification is required.

mc\_052708\_1210

### Off-season shut-down procedure

1. Switch off electrical power.
2. Remove enclosure.
3. Shut off water supply to makeup valve.
4. Drain evaporating chamber, and clean if necessary following instructions in this manual.
5. Replace enclosure.
6. Leave chamber dry, power off and the water shut-off valve closed until the next humidification season.

**Table 35-1:  
Vapormist torque specifications**

Screw or lug location		Torque	
		inches - lbs	Nm
Power block		16	1.8
Contactor		16	1.8
Heater nut	8-32 (8.5 mm) nut	20	2.2
	10-32 (9.5 mm) nut	25	2.8
Heater wire lug	6 gauge (10 mm <sup>2</sup> ) wire	35	4.0
	8 gauge (6 mm <sup>2</sup> ) wire	25	2.8
	10-14 gauge (<6 mm <sup>2</sup> ) wire	20	2.2

---

## Maintenance: Vapormist DI/RO water models

---

### WARNING!

Do not remove the humidifier electrical panel cover or the heater terminal cover until electrical power is disconnected. Contact with energized circuits can cause property damage, severe personal injury or death as a result of electrical shock or fire.

Only qualified electrical personnel should perform start-up procedure.

---

---

### WARNING!

Opening the drain valve when the tank is hot can discharge water with a temperature up to 212 °F (100 °C) into the plumbing system. This can cause damage to the plumbing system if the humidifier is not properly connected to a DRI-STEEM Drane-kooler.

Do not touch the tank or drain piping until the unit has had sufficient time to cool, or serious injury can occur.

---

### DI water models (Vapormist-DI)

Vapormist DI models use DI/RO water. Because these water types are mineral-free, cleaning the evaporating chamber should not be necessary. However, there are some maintenance steps that should be followed to ensure all parts of the unit are in working order.

**Important:** Verify regularly that water processing equipment is operating correctly. The presence of chlorides in improperly processed DI water will eventually cause pitting and failure of the humidifier tank and its components. Damage caused by chloride corrosion is not covered by your DRI-STEEM warranty

mc\_052708\_0830

### To inspect and service

1. Remove the evaporating chamber.
    - Remove the two fasteners on each side of the cover enclosure.
    - Remove the enclosure.
- 

### WARNING!

Do not remove the humidifier electrical panel cover or the heater terminal cover until electrical power is disconnected. Contact with energized circuits can cause property damage, severe personal injury or death as a result of electrical shock.

---

- If the Vapormist has a space distribution unit (SDU) mounted directly above it, the SDU cover must be removed before removing the humidifier cover.
- If the tank is hot, cool it down by opening the manual ball valve on the side of the tank. The float valve will open allowing cool water to run into the tank until it is cool enough to handle.
- Shut off the water supply.
- Allow the tank to drain completely.
- Shut off the electrical supply.
- Disconnect the fill line at the fill fitting.
- Disconnect the electrical plugs between the tank components and the back of the electrical panel (includes: power plug, low water switch plug, tank temperature sensor plug and thermal trip plug).

**Important:** Disconnect by pulling on plug housing. Do not disconnect by pulling on cord or wires.

- Disconnect the drain union on the back left corner of the frame.
- Disconnect the steam supply hose from the top of the tank.
- Lift the tank foot above the frame flange and slide the tank assembly forward to remove.

mc\_071408\_1020-2

More on the next page ►

---

## Maintenance: Vapormist DI/RO water models, continued

2. Loosen the four cover bolts and remove the cover assembly from the tank.
3. Inspect the tank interior for debris or pitting.
4. Inspect the valve inlet for debris.
5. Check the operation of the float valve and the condition of the float seat.
6. Check the low water switch to make sure the float slides freely on the stem.
7. Secure the chamber cover making sure the cover gasket is seated and the chamber is sealed.
8. Reinstall the evaporating chamber.
  - Reconnect the fill line.
  - Reconnect electrical plugs (plugs are color coded).
  - Reconnect drain union.
  - Reconnect vapor hose.
9. Verify electrical connections.
  - Verify that all DIN rail-mounted components are securely fastened to DIN rail.
  - Verify that all power terminal screws and lugs are tight from power block to heaters. See the table on Page 33 for torque specifications.
  - Verify that all plugs located under the humidifier cover are completely plugged in.
10. Close the drain valve.
11. Turn on the water supply.
12. Turn on the electrical power.

mc\_071408\_1020-2

### Off-season shut-down procedure

1. Switch off electric power.
2. Remove enclosure.
3. Shut off water supply to makeup valve.
4. Drain evaporating chamber by opening the drain valve. For units with end-of-season drain, refer to the Vapor-logic3 manual.
5. Replace enclosure.
6. Leave chamber dry, power off, and water shut-off valve closed until the next humidification season.

mc\_060208\_1420

# Replacement parts

**Figure 38-1:  
Humidifier replacement parts**

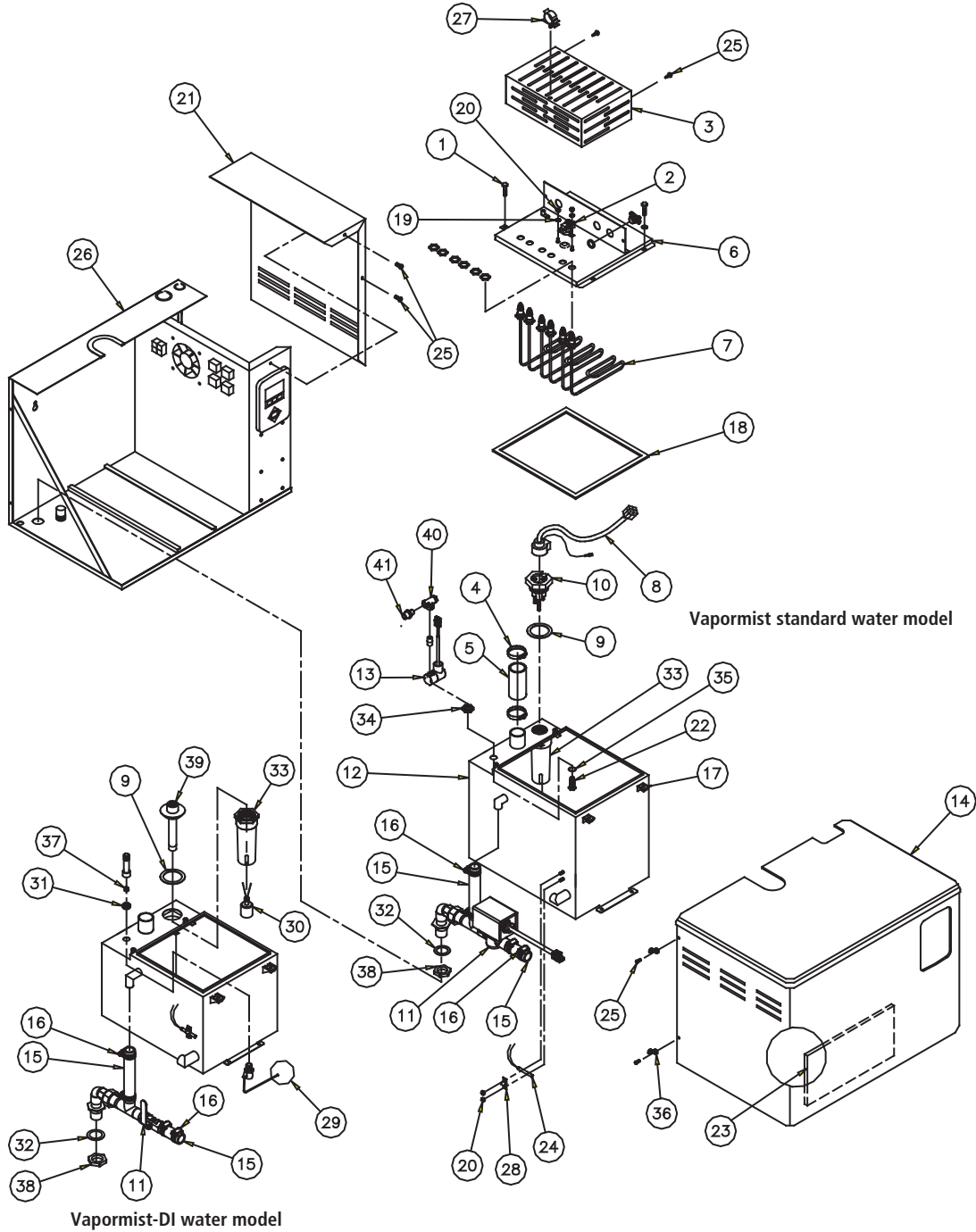

**Note:**  
Refer to the table on the next page for replacement part numbers.

OM-768



## Replacement parts, continued

**Table 39-1:  
Replacement parts**

No.	Description	Qty.	Part no.	No.	Description	Qty.	Part no.
1	Head bolt, large Phillips, ¼ - 20 × 1"	4	700300-013	20	Nut, 8-32 hex, pltd	6	700200-002
2	Thermo cut-out	1	409560-001	21	Cover, humidifier electrical panel	1	120277
3	Cover, heater terminal	1	*	22	Fill adapter, VM 2-4	1	160226-041
4	Hose clamp, 2"	2	700560-200		Fill adapter, VM 6-16	1	160224-041
5	Hose cuff, 1½"	1	305390- *		Fill adapter, VM 21-34	1	160224-052
	Hose cuff, 2"	1	305391- *	23	Panel, insulation	1	309845-003
6	Cover, tank	1	*	24	Sensor, temperature	1	197000-025
7	Heater element	*	*	25	Screw, Phillips head, 8-32 × ½"	8	700170-007
8	Probe assembly with cord and plug	1	406050-100	26	Frame assembly, chassis	1	165541
9	Gasket, 2.50" OD × 1.90" ID	1	309750-004	27	Clip, wire harness	1	405892-001
10	Probe assembly, VM 2-4	1	406303-005	28	Clip, temperature sensor	1	408251
	Probe assembly, VM 6-34	1	406303-006	29	Valve assembly, float	1	505310
11	Valve, ¾" electric, 24V	1	505400-001	30	Switch, float, 1/8" NPT	1	408420-002
	Valve, ½" SST ball	1	505000-003	31	Ring, seal, ¼"-18 NPT	1	306365
	Drain, ¼" NPT E.O.S., 24V solenoid SST w/DIN plug (not shown)	1	505086-003	32	Gasket, bulkhead, 1.60 OD × 1.15 ID	1	309750-005
12	Tank weldment	1	*	33	Probe housing, nylon, VM	1	308500
13	Fill valve, VM99	1	197000-010	34	Nut, VM heater .475	1	409601-001
14	Cabinet enclosure	1	330001-001	35	O-ring, 5/8" EPDM No. 016	1	300400-009
15	Hose, ¾" ID	2	307020-002	36	Cap, black	4	409593-002
16	Hose clamp, ¾"	4	700560-075	37	DI orifice, VM/VMDI 2-16	1	160229-041
17	Nut assembly, ¼-20, VM/VMDI 2-4	4	700650		DI orifice, VM/VMDI 21-34	1	160229-052
	Nut assembly, ¼-20, VM/VMDI 6-34	2	700650	38	Bulkhead nut	1	162721-002
18	Cover, tank gasket, VM99 2-4	1	160695-001	39	Tube weld, low water, short, VMDI 2-4	1	167787
	Cover, tank gasket, VM99 6-34	1	160695-002		Tube weld, low water, long, VMDI 6-34	1	167788
19	Washer, No. 8 external tooth, pltd	2	700200-003				

**Notes:**

- \* Specify humidifier model and serial numbers when ordering.
- Contact your DRI-STEEM representative to order parts.

## Replacement parts, continued

**Figure 40-1:**  
Space distribution unit, external absorption (SDU-E)

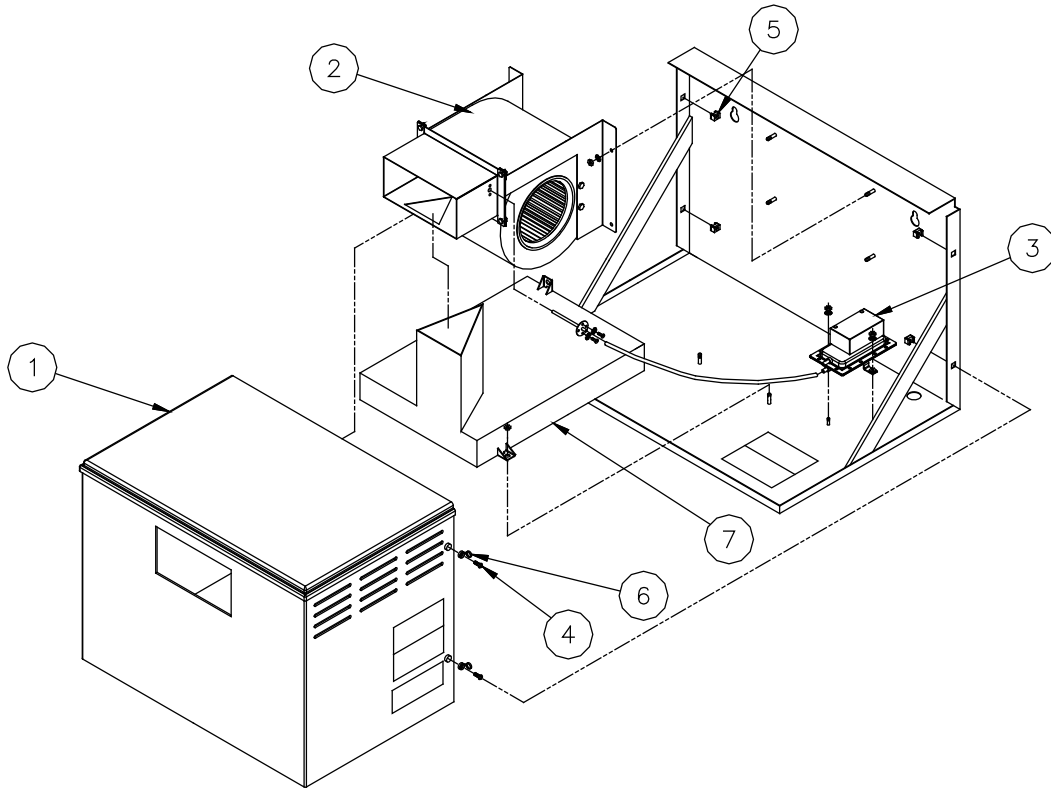

OM-1503

**Table 40-1:**  
SDU-E replacement parts

No.	Description	Qty.	Part number
1	Shroud	1	330002-001
2	Blower, SDU99 external assembly	1	*
3	Switch, airflow	1	406190
4	Screw, 8-32 × 1½" PHMS Phillips	4	700170-007
5	Nut retainer, 8-32	4	409593-001
6	Cap, black	4	409593-002
7	Dispersion chamber for SDU with 1½" outlet	1	160445-003
	Dispersion chamber for SDU with 2" outlet	1	160445-004

**Notes:**

\* This is an assembly of multiple parts.

• Contact your DRI-STEEM representative to order parts.

## Replacement parts, continued

**Figure 41-1:**  
Space distribution unit, internal absorption (SDU-I)

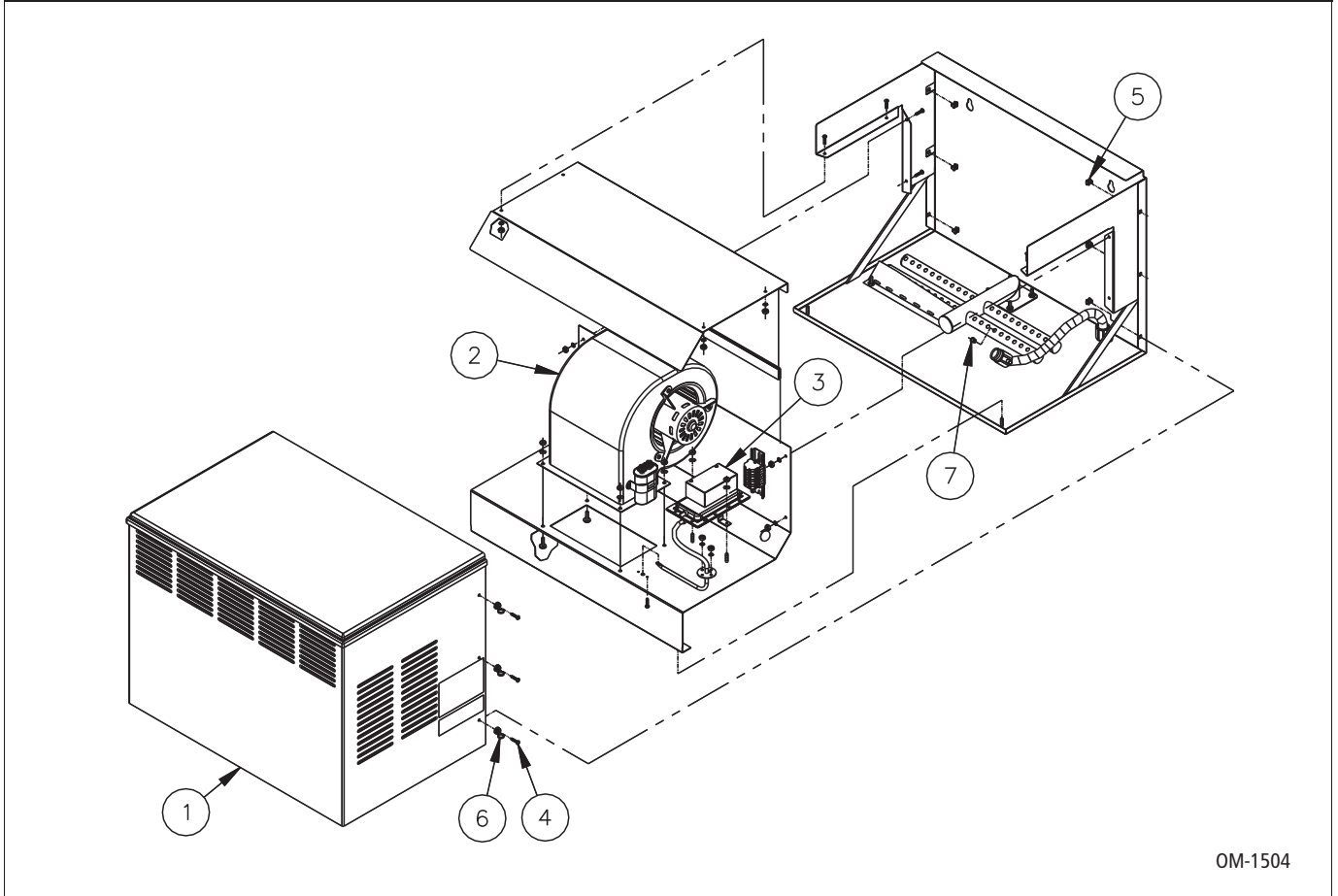

OM-1504

**Table 41-1:**  
SDU-I replacement parts

No.	Description	Qty.	Part number
1	Shroud	1	330001-002
2	Blower, SDU99 external assembly	1	*
3	Switch, airflow	1	406190
4	Screw, 8-32 × 1½" PHMS Phillips	6	700170-007
5	Nut retainer, 8-32	6	409593-001
6	Cap, black	6	409593-002
7	Tubelet, 0.375" × 0.375" molded	44	310280-006

**Notes:**

\* This is an assembly of multiple parts.

- Contact your DRI-STEEM representative to order parts.

## Replacement parts, continued

**Figure 42-1:**  
Vapormist subpanel with SSR

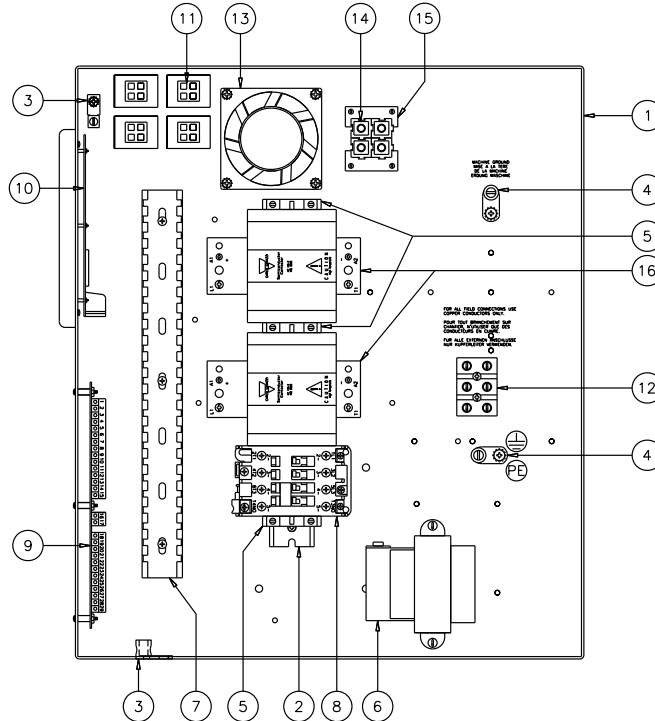

OM-213-4

**Table 42-1:**  
Subpanel replacement parts

No.	Description	Qty.	Part number	No.	Description	Qty.	Part number
1	Subpanel, VM99 barrier	1	120801	9	Main board, VL3	1	408491-x.x.xM**
2	DIN rail, 8" long	1	167765-008	10	Display board, VL3	1	408491-x.x.xD**
	DIN rail, 10.75" long	1	167765-0107	11	Plug, 4-prong female	4	409585-008
3	Lug wire	2	409250-003	12	Terminal block, 3-pole	1	408300-002
4	Ground lug, medium	2	409250-027	13	Fan, cooling	1	408667-001
5	Block, DIN rail terminal end	3	408252-006	14	Housing, 75 Amp white connector	4	409585-001
6	Transformer 120/208/240/480 V	1	408965-001	15	Plate, plug retainer	2	409585-009
	Transformer 600 V	1	408986	16	SSR, 480 V, 50 Amp, 1-pole	*	408677-002
7	Wire channel, 1" x 1"	12.5"	408999-001		SSR, 480, 50 Amp, 2-pole	*	408677-003
	Wire channel cover	12.5"	408999-002		SSR, 600 V, 2-pole	*	408677-004
8	Contact, 32 A	1	407001-020		SSR, 480 V, 60 Amp, 1-pole	*	408677-005
	Contact, 60 A	1	407001-021				

**Notes:**

- \* Refer to model for correct selection and quantity.
- \*\* Substitute Vapor-logic3 version number for "x.x.x"
- Contact your DRI-STEEM representative to order parts.

# Replacement parts, continued

**Figure 43-1:  
Vapormist subpanel with SDU**

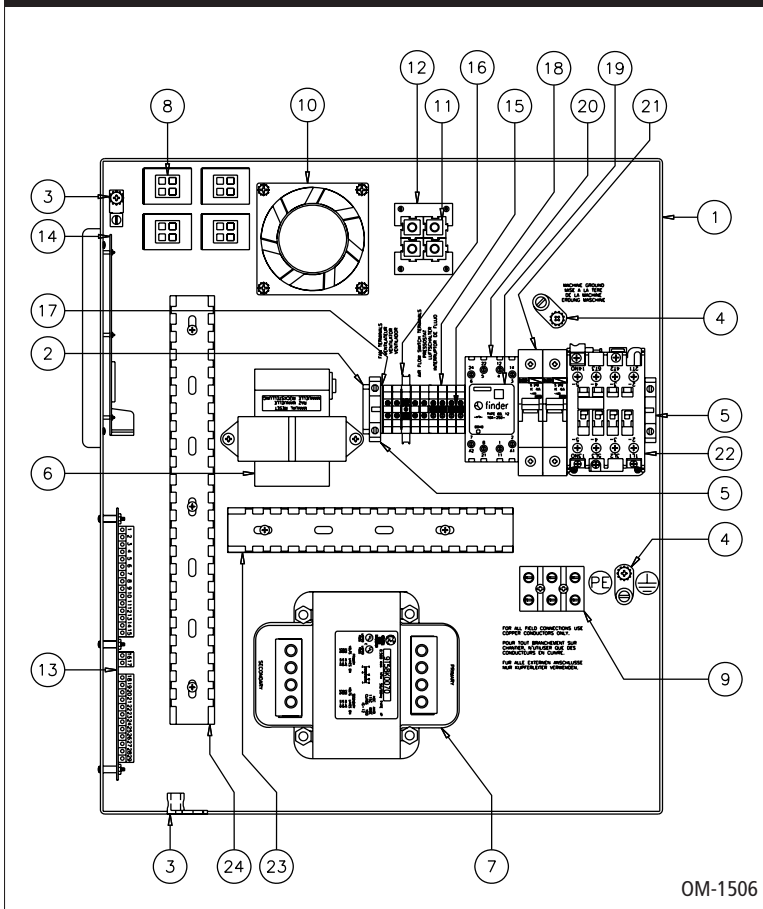

**Table 43-1:  
Subpanel replacement parts**

No.	Description	Qty.	Part number
1	Subpanel, VM99 barrier	1	120801
2	DIN rail, 8" long	1	167765-008
3	Lug wire	2	409250-003
4	Ground lug, medium	2	409250-027
5	Block, DIN rail terminal end	2	408252-006
6	Transformer 120/208/240/480 V	1	408965-001
	Transformer 600 V	1	408986
7	Transformer, 240/480 V, 300 VA	1	408991
	Transformer, 230/460/575 V, 300VA	1	408992
	Transformer, 480 V, 500 VA	1	408996-008
	Transformer, 600 V, 500 VA	1	408996-009
8	Plug, 4-prong female	4	409585-008
9	Terminal block, 3-pole	1	408300-002
	Terminal block, 4-pole	1	408300-003
10	Fan, cooling	1	408677-001
11	Housing, 75 Amp white connector	4	409585-001
12	Plate, plug retainer	2	409585-009
13	Main board, VL3	1	408491-x.x.xM
14	Display board, VL3	1	408491-x.x.xD
15	Terminal, DIN rail mount	8	408252-001
16	Terminal, ground	1	408252-010
17	End cap, DIN rail mount	1	408252-005
18	Jumper, marathon terminal	2	408252-009
19	Relay, 24V DPDT finder	1	407900-016
20	Relay socket	1	407900-019
21	Circuit breaker, 1.6 A, 1-pole	*	406775-007
	Circuit breaker, 4 A, 1-pole	*	406775-009
	Circuit breaker, 600V, 1.5 A, 1-pole	*	406775-003
22	Contactor, 60 A	1	407001-021
22	Contactor, 32 A	1	407001-020
23	Channel, wire cover	8"	408999-002
	Channel, wire	8"	408999-001
24	Channel, wire cover	12.5"	408999-002
	Channel, wire	12.5"	408999-001

**Notes:**

- \* Refer to model for correct selection and quantity.
- \*\* Substitute Vapor-logic3 version number for "x.x.x"
- Contact your DRI-STEEM representative to order parts.

---

## Notes

---

## Notes

## Expect quality from the industry leader

For over 40 years, DRI-STEEM has been leading the industry with creative and reliable humidification solutions. Our focus on quality is evident in the construction of this humidifier, which features cleanable, stainless steel construction, and an industry-leading Two-year Limited Warranty.

## For more information

www.dristeem.com  
sales@dristeem.com

**For the most current product information, visit our Web site: [www.dristeem.com](http://www.dristeem.com)**

## DRI-STEEM Corporation

An ISO 9001: 2000 certified corporation

U.S. Headquarters:  
14949 Technology Drive  
Eden Prairie, MN 55344  
800-328-4447  
952-949-2415  
952-229-3200 (fax)

European office:  
Marc Briers  
Grote Hellekensstraat 54 b  
B-3520 Zonhoven  
Belgium  
+3211823595 (voice)  
+3211817948 (fax)  
E-mail: [marc.briers@dristeem.com](mailto:marc.briers@dristeem.com)

Continuous product improvement is a policy of DRI-STEEM Corporation; therefore, product features and specifications are subject to change without notice.

DRI-STEEM, Vapormist, Dri-calc, Rapid-sorb, Ultra-sorb, and Vapor-logic3 are registered trademarks of DRI-STEEM Corporation and are filed for trademark registration in Canada and the European community.

Drane-kooler is a trademark of DRI-STEEM Corporation.

© 2009 DRI-STEEM Corporation



Form No. VM-IOM-0509  
Part No. 890000-201 Rev E

## Two-year Limited Warranty

DRI-STEEM Corporation (“DRI-STEEM”) warrants to the original user that its products will be free from defects in materials and workmanship for a period of two (2) years after installation or twenty-seven (27) months from the date DRI-STEEM ships such product, whichever date is the earlier.

If any DRI-STEEM product is found to be defective in material or workmanship during the applicable warranty period, DRI-STEEM’s entire liability, and the purchaser’s sole and exclusive remedy, shall be the repair or replacement of the defective product, or the refund of the purchase price, at DRI-STEEM’s election. DRI-STEEM shall not be liable for any costs or expenses, whether direct or indirect, associated with the installation, removal or reinstallation of any defective product. The Limited Warranty does not include cylinder replacement for electrode steam humidifiers.

DRI-STEEM’s Limited Warranty shall not be effective or actionable unless there is compliance with all installation and operating instructions furnished by DRI-STEEM, or if the products have been modified or altered without the written consent of DRI-STEEM, or if such products have been subject to accident, misuse, mishandling, tampering, negligence or improper maintenance. Any warranty claim must be submitted to DRI-STEEM in writing within the stated warranty period. Defective parts may be required to be returned to DRI-STEEM.

DRI-STEEM’s Limited Warranty is made in lieu of, and DRI-STEEM disclaims all other warranties, whether express or implied, including but not limited to any IMPLIED WARRANTY OF MERCHANTABILITY, ANY IMPLIED WARRANTY OF FITNESS FOR A PARTICULAR PURPOSE, any implied warranty arising out of a course of dealing or of performance, custom or usage of trade.

DRI-STEEM SHALL NOT, UNDER ANY CIRCUMSTANCES BE LIABLE FOR ANY DIRECT, INDIRECT, INCIDENTAL, SPECIAL OR CONSEQUENTIAL DAMAGES (INCLUDING, BUT NOT LIMITED TO, LOSS OF PROFITS, REVENUE OR BUSINESS) OR DAMAGE OR INJURY TO PERSONS OR PROPERTY IN ANY WAY RELATED TO THE MANUFACTURE OR THE USE OF ITS PRODUCTS. The exclusion applies regardless of whether such damages are sought based on breach of warranty, breach of contract, negligence, strict liability in tort, or any other legal theory, even if DRI-STEEM has notice of the possibility of such damages.

By purchasing DRI-STEEM’s products, the purchaser agrees to the terms and conditions of this Limited Warranty.

## Extended warranty

The original user may extend the term of the DRI-STEEM Limited Warranty for a limited number of months past the initial applicable warranty period and term provided in the first paragraph of this Limited Warranty. All the terms and conditions of the Limited Warranty during the initial applicable warranty period and term shall apply during any extended term. An extended warranty term of an additional twelve (12) months or twenty four (24) months of coverage may be purchased. The extended warranty term may be purchased until eighteen (18) months after the product is shipped, after which time no extended warranties are available.

Any extension of the Limited Warranty under this program must be in writing, signed by DRI-STEEM, and paid for in full by the purchaser.

mc\_051308\_0630



Printed on 30% recycled paper