

READ AND SAVE THESE INSTRUCTIONS

VAPORFAN[®] and VAPORFAN[®] DI ELECTRIC STEAM HUMIDIFIERS

For applications not served by a central duct system

Installation Instructions and Maintenance Operations Manual

For Toll-Free Technical Support,
Call 1-800-328-4447



UL LISTED

DRISTEEM[®]
HUMIDIFIER COMPANY



TABLE OF CONTENTS

TO THE PURCHASER AND THE INSTALLER

We have done our best to provide a product that will give many years of satisfactory service. We request that you spend a few moments to familiarize yourself with these tips for installation and maintenance. Doing so may prove to pay big dividends over the years to come in the form of better performance and easier maintenance.

DRI-STEEM Humidifier Company

Installation	5
Operation	6
Electrical/Piping	7
Mechanical/Electrical Specifications	8
Maintenance Procedures	9-10
Replacement Parts	11-13
Maintenance Service Record	14
DRI-STEEM Warranty	15

PLEASE NOTE: Standard unit requires minimum water conductivity of 100 μ mhos/cm (2 grains/gallon) to function and therefore will not operate on water treated by the reverse osmosis or deionizing process. However, if you plan to use either of these water types, a unit specifically designed for use with deionized water is available. (Model VFDI)

VAPORFAN® HUMIDIFIER

Designed To Be Attractive, Efficient and Quiet

Steam is injected into the airstream generated by the blower. Specially designed steam dispersion system makes sure that vapor is completely absorbed by the air before reaching the exit grill on the front of the unit.

VAPORFAN

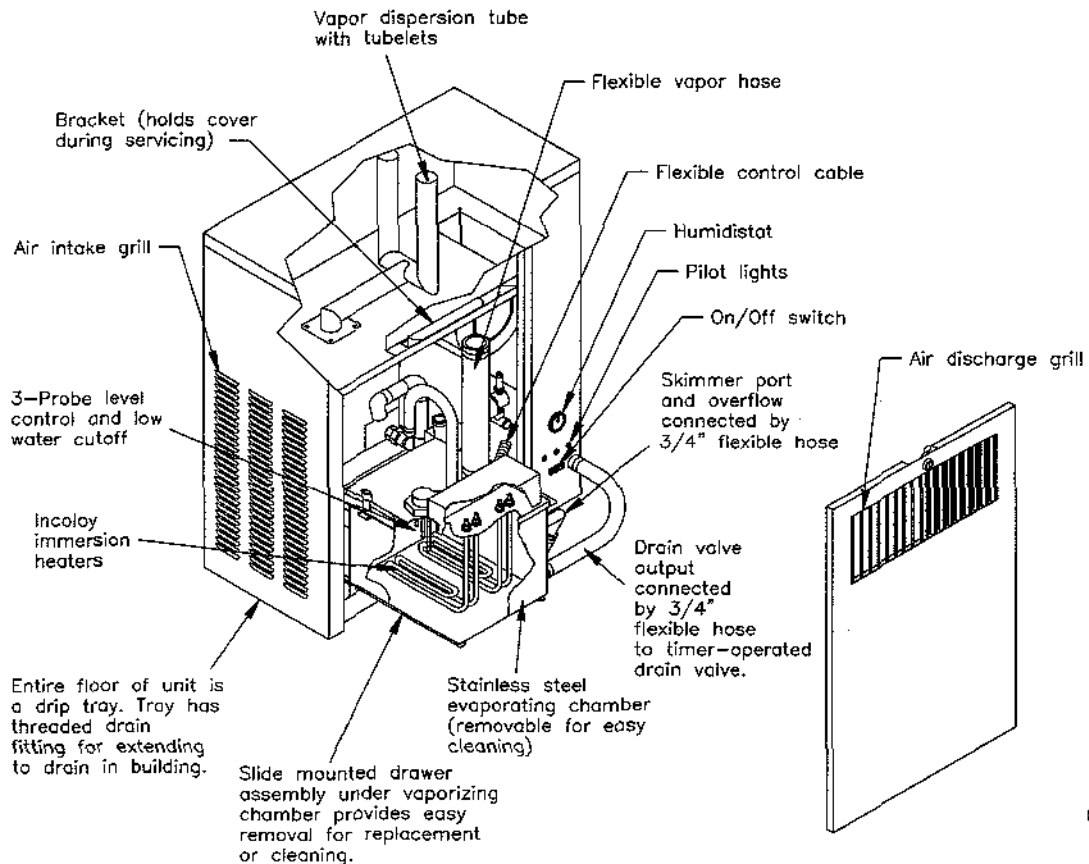

OM-402

VAPORFAN® DI HUMIDIFIER

Maintenance Dramatically Reduced With Model DI

The VAPORFAN DI humidifier is designed for use with DI/RO water. Standard VAPORFAN units require a minimum water conductivity of 100 $\mu\text{m}/\text{cm}$ (2gr/gal) to operate. They will not operate with water treated by reverse osmosis or deionization processes. Because DI and RO water

types are mineral-free, you never need to clean the vaporizing chamber. This saves you both time and maintenance personnel costs.

In addition to low maintenance, the VAPORFAN DI provides a more consistent output than a regular VAPORFAN humidifier. The unit doesn't need to flush off excess minerals, and so the humidity output of the unit is extremely consistent.

The VAPORFAN DI

humidifier is similar to the standard VAPORFAN in every way except for the vaporizing chamber. The DI unit's vaporizing chamber is constructed of corrosion resistant stainless steel alloy with special heli-arc welded seams to resist the corrosive effects of mineral-free water.

Designed for DI water with a maximum resistance of 18 $\text{m}\Omega/\text{cm}$ at 25°C/77°F. Minimum water pressure 30 psi.

Note: All information in this manual pertains to both the VAPORFAN and the VAPORFAN DI unless specifically stated otherwise.

VAPORFAN DI

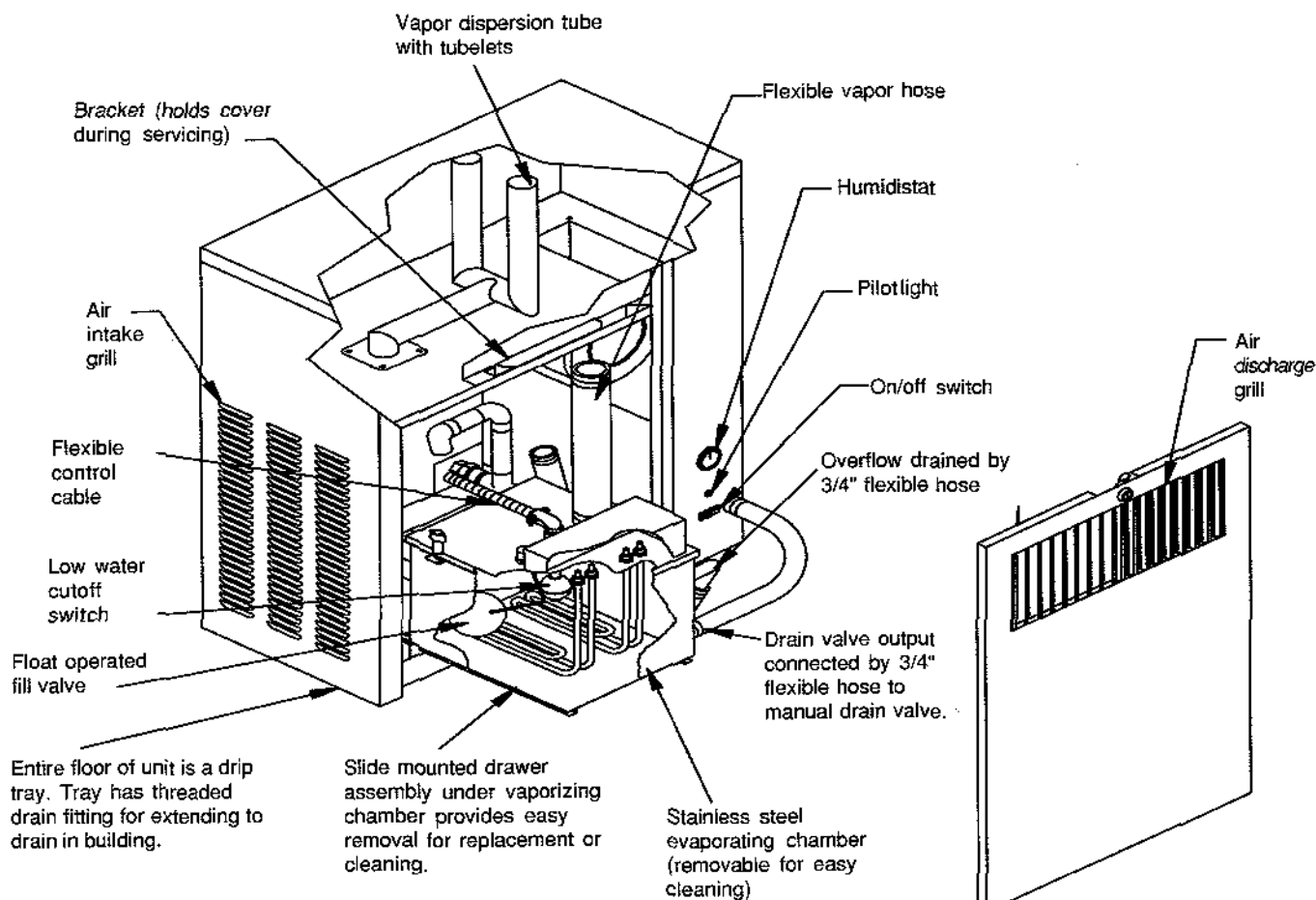

om-403

INSTALLATION

Selecting the installation location

The VAPORFAN® humidifier has an attractively designed cabinet intended for installation in finished rooms or spaces. A hanging bracket is furnished for wall mounting the humidifier.

Mounting location of the VAPORFAN

When deciding where to locate the unit within the room or space, several items should be taken into consideration. Among these are ease of providing services (electrical and piping), vapor distribution, and noise.

Services

Usually ease of wiring and providing water supply and drain piping to the VAPORFAN humidifier will head the priority list in the choice of a mounting location. The outside service connections (electrical, water supply and drain) are made at the lower right rear corner of the unit. Also keep in mind that a mounting location should be selected that provides convenient access to the front of the unit for vaporizing chamber removal.

Air and vapor movement

The air inlet to the unit must not be obstructed. At least 3" of clearance must be maintained between the air inlet grill and nearby surfaces. Starvation of the air supply will result in incomplete absorption of the water vapor within the humidifier and could cause condensation on the vanes of the air discharge grill.

No auxiliary air movement

The vapor pressure in the immediate area of the humidifier tends to build up, and this causes the vapor to migrate to the remote parts of the room or space because pressures tend to equalize. These pressure differences are very slight, however, and so migration is by no means instantaneous. For that reason the location selected should favor the center of the room. For example, in the case of a long narrow room, the center point of one of the two long walls would be most ideal. See sketch "A."

Sketch "A"

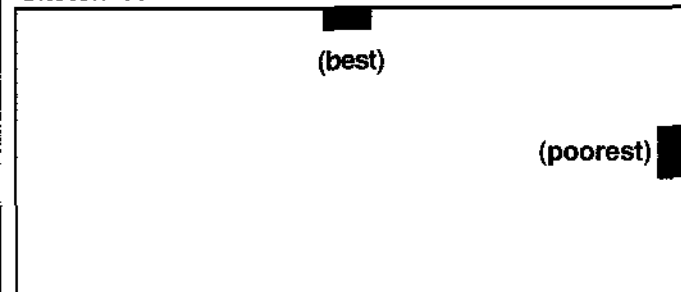

With auxiliary air movement

In cases where air movement is created within the room or space due to an air handling system (furnace or air conditioner), the path or direction of airflow should be

considered. Since water vapor will be carried by the air in motion, the humidifier location should favor the upstream or source of the incoming air, thus using the air movement as an assistance for achieving dispersion of the vapor. See sketch "B."

Sketch "B"

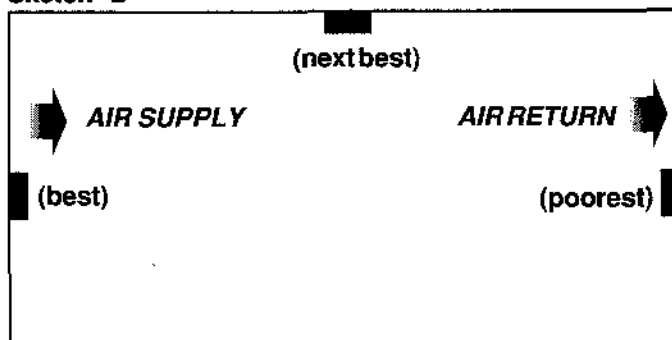

Confined spaces

The VAPORFAN humidifier should not be located in a confined cubicle adjacent to a larger space. Doing so could result in humidity buildup in the cubicle faster than it can migrate away. This could result in the humidifier shutting itself off before satisfying the needs of the adjacent larger space. See sketch "C."

Sketch "C"

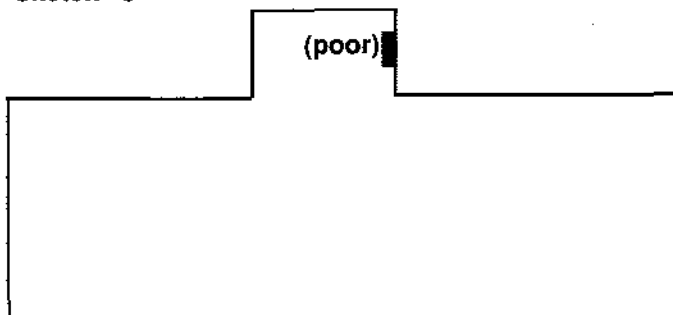

Mounting methods

The VAPORFAN humidifier can be either set directly on the floor or wall mounted at a suitable elevation above the floor. When wall mounting, the hanging bracket is required. The wall mounting bracket and two 3/8" lag bolts are provided with each unit.

Studded Wall Mounting (16" on center studs)

Locate studs and position mounting bracket in place so the two 16" on-center holes will catch a stud. Mark hole location and pre-drill 1/4" diameter pilot holes. Secure bracket to wall with the lag bolts provided.

Hollow block or poured concrete wall mounting

Position mounting bracket in place and mark the second hole from each end. Drill appropriate pilot hole for two 3/8" toggle bolt or two 3/8" machine bolt lead anchor. Secure bracket in place using selected method.

OPERATION

Reliable, Electronic Probe Control Maintains Water Level (Standard VAPORFAN®)

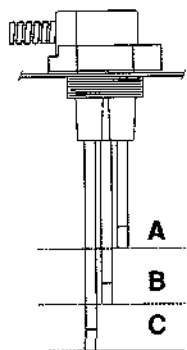

OM-211

A simple 3-probe conductivity sensor cycles a solenoid-operated water fill valve to maintain the proper water levels. Water conductivity: 100 μ mhos/cm minimum (2 grain/gal).

Surface Skimming

Each time the vaporizing chamber refills, the previously formed floating mineral residue is skimmed off through the skimming port. This port is located slightly below level "A" in above drawing. Each time the unit refills, the water expands and boils causing approximately 1/8" of mineral laden water to skim. The waterline continues to drop by evaporation to level "B" at which time the refill process is repeated. This skimming action reduces mineral concentration in much the same way as the surface blow down on a steam boiler and reduces the frequency of cleaning.

LW415 Control System

Initial Start-Up

When the power is first turned on, the solenoid operated waterfill valve opens and begins filling the vaporizing chamber. Filling will continue until water reaches level "A," and then the fill valve closes. To ensure that a water seal is created in the overflow hose, disconnect probe plug (item 22, page 11) and cable from probe rod assembly located on cover to allow the fill valve to re-energize and overflow humidifier tank. This process will only take a few seconds; you must then reconnect it. A call for humidity will then energize the heating element.

Water Refill

During operation the water line will drop to level "B." At this time the fill valve opens. The fill valve will remain open until the water line returns to level "A."

Low Water Protection

During operation, if the water line drops below level "C," the heaters are de-energized. The heater will remain "off" until the water line has been restored to level "C." This action provides low water protection in the event of water supply failure.

Drain/Flush Feature

The control module contains an integral electronic timer, which accumulates the "on," or "humidifying" time of the VAPORFAN. When this accumulated time reaches the setting of the timer, the drain/flush cycle is activated.

Upon activation, the following sequence occurs:

1. The drain valve opens and the mineral-rich contents of the evaporator chamber begins draining.
2. When this water drops to the "refill" level, the fill valve opens.
3. Both fill and drain valves remain open for ten more minutes, thus flushing the tank.
4. The drain valve then closes, the tank refills, the fill valve closes, the timer begins accumulating time, and the VAPORFAN resumes normal operation.

The electronic timer comes factory-set at 40 hours. Alternate times of 20 hours and 80 hours can be made. See wiring diagram on subpanel cover of humidifier.

Test cycling the drain/flush system

The timer contains four pairs of terminal pins, which are marked 20, 40, 80 and "T" (for test).

To test:

1. Pull the pin block off whichever pair of pins is in use; move it to the "T" pair and push it in.
2. Set the humidistat high enough so the VAPORFAN will remain "on call" for at least one hour.
3. After about 35 minutes of running time, activation will take place, causing the drain valve to open. The water level will then drop and cause the "fill" valve to open. Both valves will remain open for about 10 minutes.
4. The "drain" valve will then close and the water level will rise, causing the "fill" valve to close.
5. Once the test cycle is completed, move the pin block back to the appropriate hourly pair of pins. Failure to do so will result in a drain/flush cycle every 35 minutes.

Makeup Water (Unsoftened Water)

For cases with water of less than 10 grains per gallon hardness, the skimmer system alone, without softening, usually provides a full season or more of humidification without a need for cleaning the evaporator.

The optional timer-operated drain/flush feature is available for cases in which water hardness is above 10 grains per gallon and where softened water is not available. When this option is furnished, the humidifier control contains an integral adjustable timer that accumulates the "on" or actual humidifying time of the unit. When this accumulated time reaches the amount previously adjusted for in the controller, the drain/flush cycle is activated.

OPERATION

Makeup Water (Softened Water)

When the untreated water hardness exceeds 10 grains per gallon, softened water is recommended. There are three major advantages derived from using softened instead of unsoftened water.

The first is reduced maintenance.

The skimmer, in conjunction with softened water, is an unbeatable combination for eliminating scale formation in the evaporating chamber. Several seasons of operation with no need for cleaning is normal, even with water having up to 30 grains of dissolved minerals per gallon prior to being softened.

The second is accuracy of control.

When softened water is used, the skimmer bleed-off quantity can be greatly reduced, and the frequency of the drain/flush sequence can be cut back and even eliminated in some cases. When this is done it improves controllability.

The third of course, is economy of water usage.

A reduction of the drain and flush cycles almost eliminates waste.

Softened water produces far less mineral buildup.

The explanation for this phenomenon of reduced mineral precipitation, and thus reduced water usage, is quite simple. The softening process exchanges magnesium and calcium ions for sodium ions. Sodium ions are many times more soluble and therefore remain in solution at a much higher concentration. The skimmer, by continually bleeding off a small quantity of water with each refill cycle, keeps the sodium concentration low enough so that drain/flush is not needed to eliminate scale formation.

ELECTRICAL/PIPING

Electrical and piping

The VAPORFAN® is a self-contained, factory-assembled and wired, humidifier unit. It can be installed in any location where (1/4") copper or plastic water supply and 3/4" minimum copper (or plastic, rated 212°F) drain piping and power wiring can be connected to the unit.

The fan motor and control circuit requires 120 V, 50/60 Hz, 1 ph. supply. On installations where the heater circuit is of another voltage, an additional supply circuit of that voltage is required.

The wiring diagram is placed on the inside of the control cabinet on the VAPORFAN humidifier.

Drain Through or Within Wall

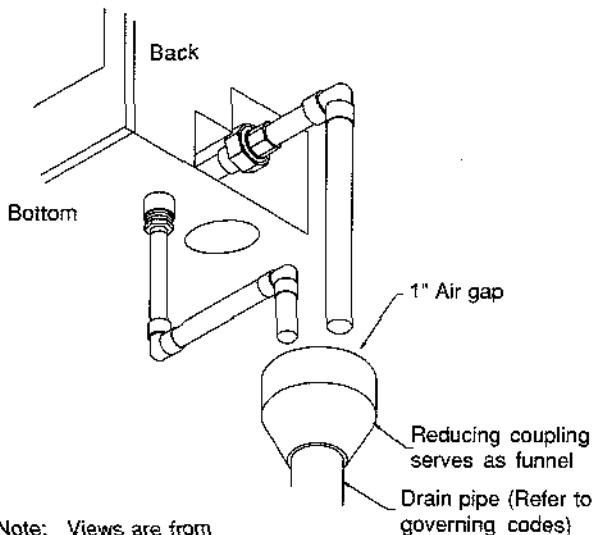

OM-249

Drain to Floor or Adjacent to Wall

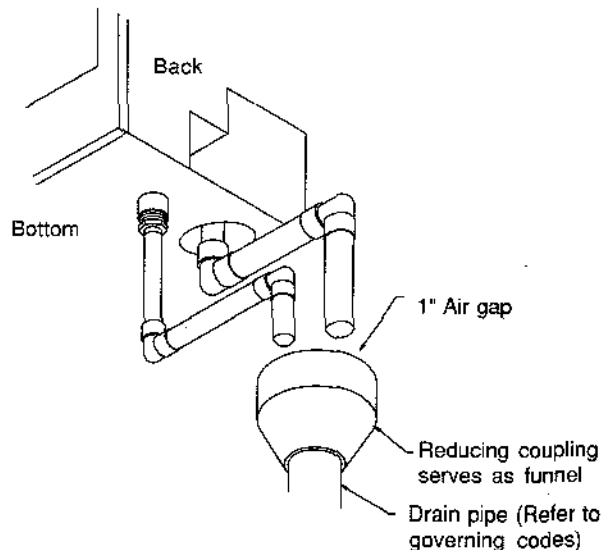

OM-248

MECHANICAL/ELECTRICAL SPECIFICATIONS

Table 8-1: Mechanical/Electrical Specifications and Capacities

	VF20		VF40		VF60		VF85		VF100		VF120	
	inches	mm	inches	mm	inches	mm	inches	mm	inches	mm	inches	mm
Dim. A	12.88	327.00	12.88	327.00	15.88	403.00	15.88	403.00	15.88	403.00	15.88	403.00
Dim. B	30.00	762.00	30.00	762.00	35.00	889.00	35.00	889.00	35.00	889.00	35.00	889.00
Dim. C	25.88	657.00	25.88	657.00	29.38	746.00	29.38	746.00	29.38	746.00	29.38	746.00
Dim. D	20.00	508.00	20.00	508.00	23.00	584.70	23.00	584.70	23.00	584.70	23.00	584.70
Dim. E	1.08	27.00	1.08	27.00	1.89	48.00	1.89	48.00	1.89	48.00	1.89	48.00
Fan Output	290.00 cfm	8.20 cmm	435.00 cfm	12.30 cmm	980.00 cfm	27.80 cmm	980.00 cfm	27.80 cmm	980.00 cfm	27.80 cmm	980.00 cfm	27.80 cmm
Op. Weight	130 lb	59 kg	130 lb	59 kg	198 lb	90 kg	198 lb	90 kg	198 lb	90 kg	198 lb	90 kg
Shp. Weight	125 lb	57 kg	125 lb	57 kg	165 lb	75 kg	165 lb	75 kg	165 lb	75 kg	165 lb	75 kg
AMPS 120/1	16.70		-		-		-		-		-	
* 208/1/3 wire	9.60		19.20		26.80		43.30		-		-	
* 240/1/3 wire	8.30		16.70		25.00		37.50		41.70		-	
* 480/1	4.20		8.30		12.50		18.80		20.80		25.00	
* 208/3/4 wire	-		16.70**		25.00**		25.00		29.10**		33.30	
* 240/3/4 wire	-		14.40**		21.70**		21.70		25.30**		28.90	
* 480/3	-		7.20**		10.80**		10.80		12.60**		14.40	
KW	2.00		4.00		6.00		9.00		10.00		12.00	
Output/hour lb/gal/kg	6/7.72/7 12/1.4/5.4		12/1.4/5.4 27/3.2/12.2		18/2.2/8.2 36/4.4/16.4		27/3.2/12.2		30/3.6/13.6		36/4.4/16.4	

*All VAPORFAN® humidifiers operate on 50/60 Hz and require 120 volt single phase control circuit and fan supply in addition to heater circuit. When heater voltage is other than 120/1/50-60, a second circuit of that voltage is required.

On 208/240 single (3 wire) and 3 phase (4 wire) supplies the neutral line may be utilized for 120 volt. 480 volt requires a stepdown transformer (by others) 480-120/v sec. (.3KVA: VF 20-40, 1.0 KVA: VF 60-120.)

** For wire sizing. Highest line draw is shown due to current unbalance in some cases.

Table 8-2: Capability

Unit	Approximate Humidifying Capability (sq. ft.)
VF20	2000
VF40	4000
VF60	6000
VF85	8500
VF100	10000
VF120	12,000

NOTE: Above estimates based on the following:

- indoor Conditions = 70°F. and 40% RH
outdoor Conditions = 0°F. and 80% RH
- one air change per hour, which is:
 - average for a space that has no air conditioning or ventilation system
 - average for a space that is air conditioned but has no outside air intake
- Above capacity capabilities are merely "rule of thumb" estimates. Actual requirements will vary.

The elevation above the floor should be convenient for servicing the VAPORFAN and must permit adequate pitch of the drainage piping.

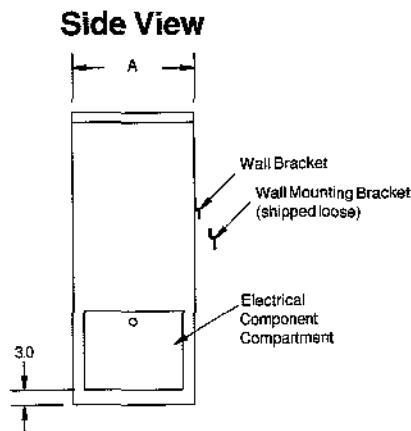

Rear View

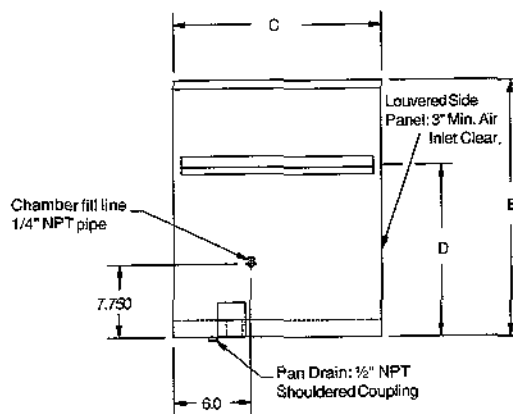

Bottom View

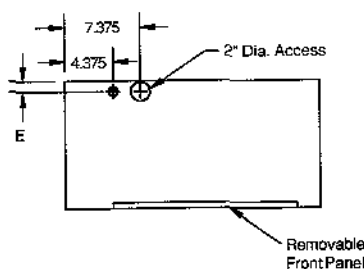

Note: Allow 3" minimum air clearance between louvered side panel and any obstructions.

MAINTENANCE PROCEDURE

Unique design for minimum maintenance - easy as 1-2-3-4.

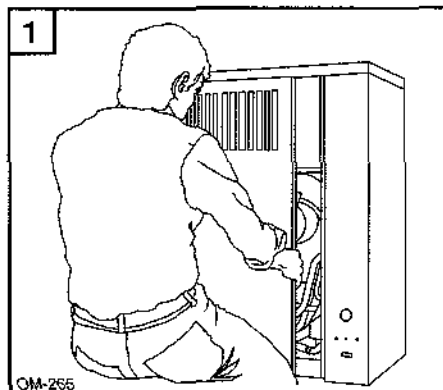

1. Shut off electrical power to unit. Using key, unlock and remove large front panel. Drain the evaporating chamber by manually opening the "drain" valve. Do this by pushing open lever on valve to "manual" position and lock in place.

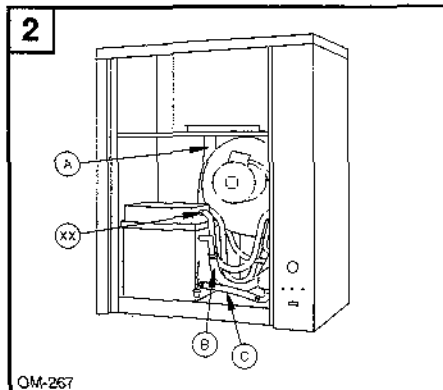

2. Disconnect flexible vapor hose (A) on top of evaporating chamber. Do not disconnect any of the electrical conduits (XX). Disconnect the flexible hose from the overflow pipe (B), and the flexible hose from the evaporating chamber (C). All disconnects can be made at the evaporating chamber.

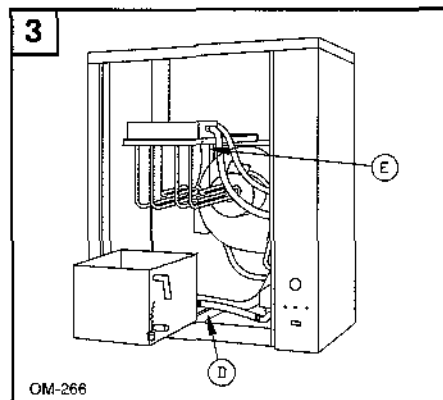

3. Pull evaporating chamber out of unit on sliding track (D). Remove cover of chamber, raise and slide into holding slots (E) above upper part of unit. Remove soiled evaporating chamber and clean. Replace chamber cover and slide chamber back into unit.

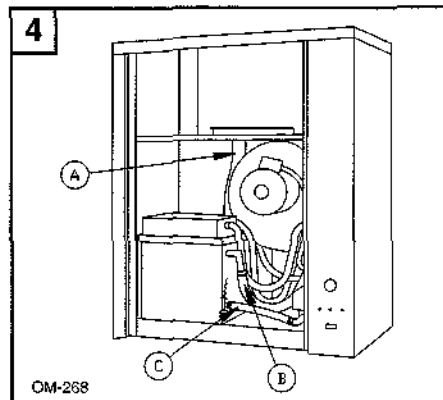

4. Reconnect flexible steam hose (A). Reconnect overflow hose (B), drain hose (C), replace front panel. Turn on electrical power. VAPORFAN is again ready to humidify. Return drain valve lever to "auto" position.

In addition to the skimmer, a timer and drain/flush system are incorporated into the operating system (see page 6 for operation description). The timer is field adjustable for 20, 40, 80 hour drain/flush system intervals. Drain/flush duration is 10 minutes.

Cleaning the evaporating chamber

The heating element itself is usually self-cleaning. The mineral buildup on the element flakes off after reaching a thickness of about 1/16", and it settles to the bottom of the chamber. Before scale accumulation builds up to the underside of the heating element, it must be removed. Failure to do so will result in premature heater burnout.

To remove loose scale, simply scoop it out. Scale adhering to the walls of the chamber can be loosened by using a scraper.

Note: An additional evaporating chamber may be ordered. This allows quick change out at mounted location. Then the used chamber may be taken to maintenance for cleaning. DRI-STEEM recommends using softened water to greatly reduce cleaning frequency.

Probe assembly

Unscrew plastic probe housing and remove any mineral buildup that may have accumulated.

Electro-rod assembly

The buildup on the probe rods should be brushed or scraped off.

Reassemble VAPORFAN in reverse order, making sure chamber cover is resealed and all hose clamps are fastened.

Off season shut down

- Switch off power.
- Turn off water supply to makeup valve.
- Drain evaporating chamber (step 1, page 10) and remove scale accumulation.
- Leave chamber empty, power off and valve closed until the next humidification season.

Maintenance Procedure - (Standard VAPORFAN®)

- Clean Vaporizing Chamber, skimmer tube and probes, as required.
- VAPORFAN, Fan Motor - oil annually.
- Check fill and drain hoses annually.

Minerals precipitate

As evaporation takes place in the VAPORFAN humidifier, some of the minerals dissolved in water precipitate (come out of the solution) and float on the water surface. If not removed, this precipitate mineral will

eventually form a sludge and settle to the bottom of the vaporizing chamber.

Removes floating precipitated mineral

Each time the makeup valve opens, the unit refills to a point just above the skimmer opening. A portion of the makeup is then "skimmed" (flows to drain), carrying the floating mineral with it. This action reduces the mineral concentration in the VAPORFAN, which, in turn, reduces the required frequency of cleaning. Cleaning once or twice a season is usually adequate, assuming water having hardness of up to 10 grains of dissolved mineral per gallon. In

MAINTENANCE PROCEDURE

VAPORFAN® DI Maintenance

1. Shut off electrical power to unit.
2. Shut off water supply to makeup valve.
3. Use key to remove front panel.
4. Make sure the evaporating chamber is drained by manually opening the "drain" valve (A).
5. Oil the fan motor.
6. Check the condition of the overflow (B) and drain (C) hoses.
7. Remove the evaporating chamber as follows:
Disconnect the flexible vapor hose (D) on top of the evaporating chamber, the flexible overflow hose (B) and the flexible drain hose (C). All disconnects should be made at the evaporating chamber. **DO NOT DISCONNECT ANY OF THE ELECTRICAL CONDUITS (E).**
8. Slide the evaporating chamber forward on the sliding track. Remove the cover of the chamber, raise and slide into holding bracket (G).
9. Check operation of the float valve (H) and low water cutoff (J).
10. Inspect the heating elements. Replace if badly pitted.
11. Inspect the evaporating chamber. Clean if necessary.
12. Replace chamber cover and slide chamber back into unit.
13. Reconnect all flexible hoses.
14. Return drain valve handle (A) to "closed" position.
15. Replace front panel and turn on electric power.
16. VAPORFAN is ready to humidify again.

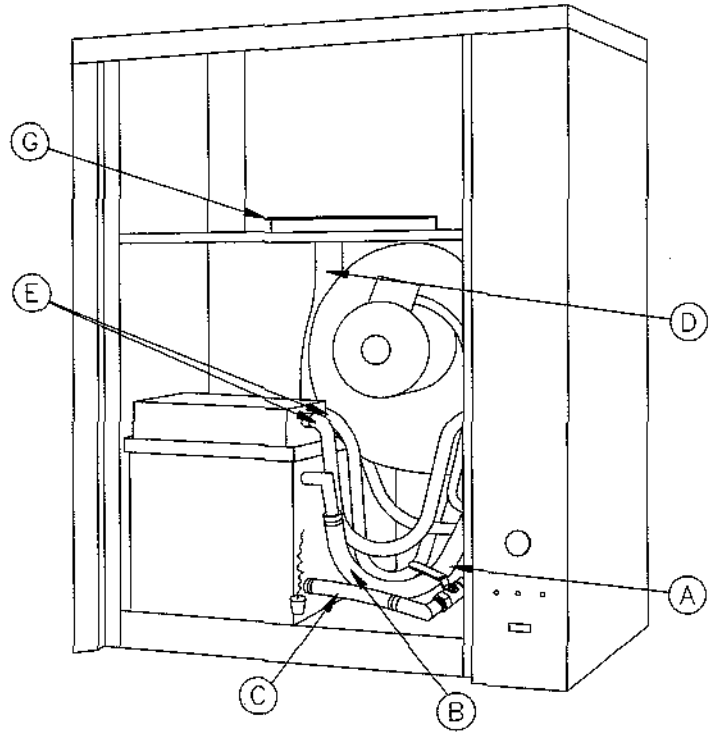

OM-264

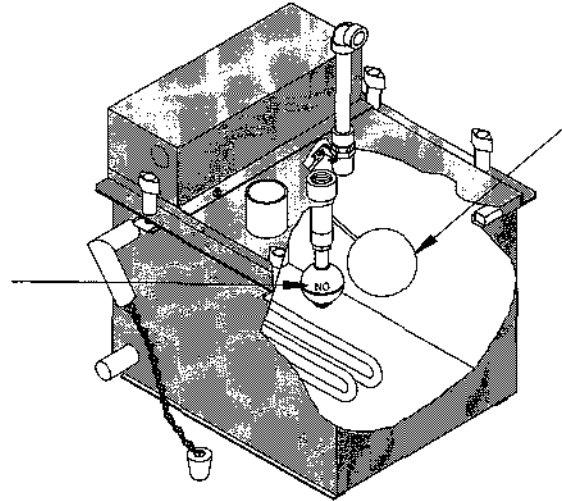

OM-105

Off Season Shut-Down Procedure

1. Switch off electric power to unit.
2. Remove front panel.
3. Shut off water supply to makeup valve.
4. Drain evaporating chamber by manually opening the drain valve.
5. Replace front panel.
6. Leave chamber dry, power off, and water-shutoff valve closed until next humidification season.

REPLACEMENT PARTS

VAPORFAN®

No.	Description	Qty.	Part No.
1	Front Panel (VF20, 40)	1	160030-101
1	Front Panel (VF60, 85, 100, 120)	1	160030-102
2	Electrical Panel (VF20, 40)	1	160100-101
2	Electrical Panel (VF60, 85, 100, 120)	1	160100-102
3	Vaporizing Tank Slides	2	309980
4	Dispersion Tube (VF20, 40)	1	160050-001
4	Dispersion Tube (VF60, 85, 100, 120)	1	160050-002
5	Restriction Orifice Nipple	1	203530
6	Sediment Strainer	1	300050
7	24 v. Fill Valve	1	505080-001
8	HC-101-801 Humidistat and Knob	1	405880
9	Power Switch	1	409500-001
10	Amber Light with Clip	1	409520-003
11	Green Light with Clip	1	409520-002
12	Red Light with Clip	1	409520-001
13	1/4" Tubelet (VF20, 40)	6	310150-003
13	1/4" Tubelet (VF60, 85, 100, 120)	16	310150-003
14	Over Flow Hose Spring	1	307025
15	1/2" Fill Hose - 21"	1	307020-001
16	1/2" Hose Clamp	2	700560-001
17	3/4" x 10" Hose (VF20, 40)	1	307020-002
17	3/4" x 15" Hose (VF60, 85, 100, 120)	1	307020-002
18	3/4" Hose Clamp	4	700560-002
19	3/4" x 5-1/2" Hose (VF20, 40)	1	307020-002
19	3/4" x 7-1/4" Hose (VF60, 85, 100, 120)	1	307020-002
20	1-1/2" x 8" Vapor Hose (VF20, 40)	1	305390-002
20	1-1/2" x 10" Vapor Hose (VF60, 85, 100, 120)	1	305390-003
21	1-1/2" Hose Clam	2	700560-003
22	Probe Plug Cap -24"	1	406050-002
23	Electric Drain Valve, 24v.	1	505400-001
24	Blower 290/435 CFM (VF20, 40)	1	409540-001
24	Blower 935 CFM (VF60, 85, 100, 120)	1	409540-002
25	Key Lock	2	700700
26	3/8" x 2" Lag Bolt	2	700540-002
27	Wall Bracket	1	160150-102

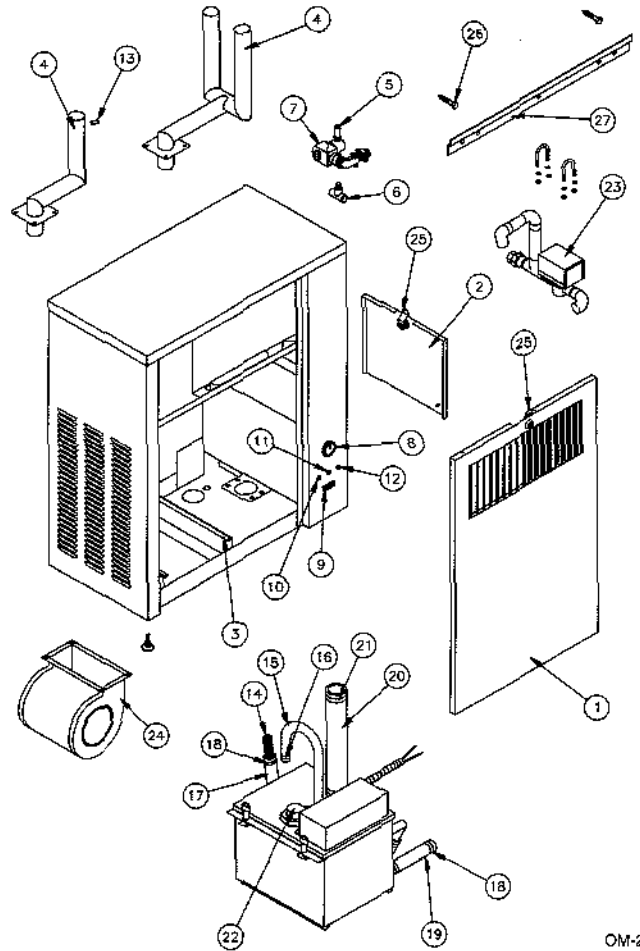

OM-235

Vaporizing Tank

No.	Description	Qty.	Part No.
29	Vaporizer Tank, 1"	1	160010
30	Vaporizer Cover, 1"	1	160020/21
31	Probe Gasket, 2"	1	309750-003
32	Probe Assembly	1	406220
33	Thermo Cut-Out	1	409560
34	Heater Terminal Cover, 1"	1	160110
35	Cover Gasket, 2"	1	309950
36	Probe Housing	1	308500
37	Heater	1*	
38	Rubber Stopper	1	309960
39	Utility Knob	4	700725

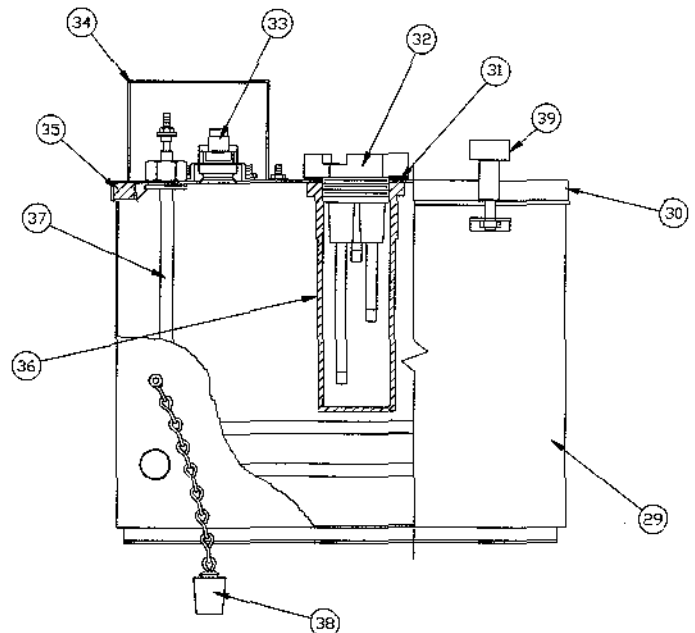

1* - Varies with specific order.

2* - Hoses, clamps and gaskets available in kit form.

OM-242

REPLACEMENT PARTS

Sub Panel For LW415

No.	Description	Qty.	Part No.
47	3 amp Fuse (VF20, 40)	1	406740-006
47	7 amp Fuse (VF60, 85, 100, 120)	1	406740-007
48	Transformer 120/24	1	408960
49	Contactors (See note 1)	1	407001
50	24 v. Relay	1	407900-001
51	1 Pole Fuse Block	1	407450-002
52	2 Pole Power Block	1	408300-001
53	3 Pole Power Block	1	408300-002
56	LW415 Level Control Board	1	408630

Note 1: Specify current rating.

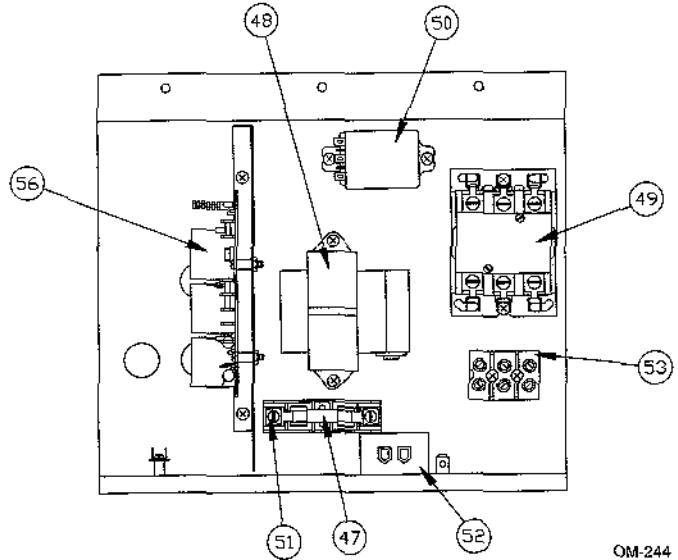

OM-244

Sub Panel For VAPORFAN® DI

No.	Description	Qty.	Part No.
47	3 amp Fuse (VFDI 20, 40)	1	406740-006
47	7 amp Fuse (VFDI 60, 85, 100, 120)	1	406740-007
48	Transformer 120/24	1	408960
49	Contactors (See note 1)	1	407001
50	24 v. Relay	2	407900-001
51	1 Pole Fuse Block	1	407450-002
52	2 Pole Power Block	1	408300-001
53	3 Pole Power Block	1	408300-002
57	Time Delay Relay	1	408440-001

Note 1: Specify current rating.

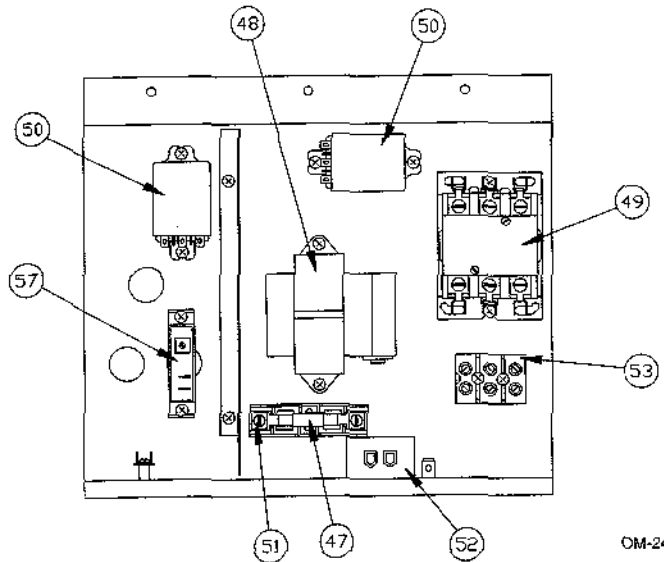

OM-246

REPLACEMENT PARTS

VAPORFAN® DI

No.	Description	Qty.	Part No.
1	Front Panel (VFDI 20, 40)	1	160030-101
1	Front Panel (VFDI 60, 85, 100, 120)	1	160030-102
2	Electrical Panel (VFDI 20, 40)	1	160100-101
2	Electrical Panel (VFDI 60, 85, 100, 120)	1	160100-102
3	Vaporizing Tank Slides	2	309980
4	Dispersion Tube (VFDI 20, 40)	1	160050-001
4	Dispersion Tube (VFDI 60, 85, 100, 120)	1	160050-002
8	HC-101-801 Humidistat and Knob	1	405890
9	Power Switch	1	409500-001
11	Green Light with Clip	1	409520-002
13	1/4" Tubelet (VFDI 20, 40)	6	310150-003
13	1/4" Tubelet (VFDI 60, 85, 100, 120)	16	310150-003
14	Over Flow Hose Spring	1	307025
17	3/4" x 10" Hose (VFDI 20, 40)	1	307020-002
17	3/4" x 15" Hose (VFDI 60, 85, 100, 120)	1	307020-002
18	3/4" Hose Clamp	4	700560-002
19	3/4" x 5-1/2" Hose (VFDI 20, 40)	1	307020-002
19	3/4" x 7-1/4" Hose (VFDI 60, 85, 100, 120)	1	307020-002
20	1-1/2" x 8" Vapor Hose (VFDI 20, 40)	1	305390-002
20	1-1/2" x 10" Vapor Hose (VFDI 60, 85, 100, 120)	1	305390-003
21	1-1/2" Hose Clamp	2	700560-003
24	Blower 290/435 CFM (VFDI 20, 40)	1	409540-001
24	Blower 935 CFM (VFDI 60, 85, 100, 120)	1	409540-002
25	Key Lock	2	700700
26	3/8" x 2" Lag Bolt	2	700540-002
27	Wall Bracket	1	160150-102
28	Valve, 3/4" Stainless Steel Ball	1	505000-001

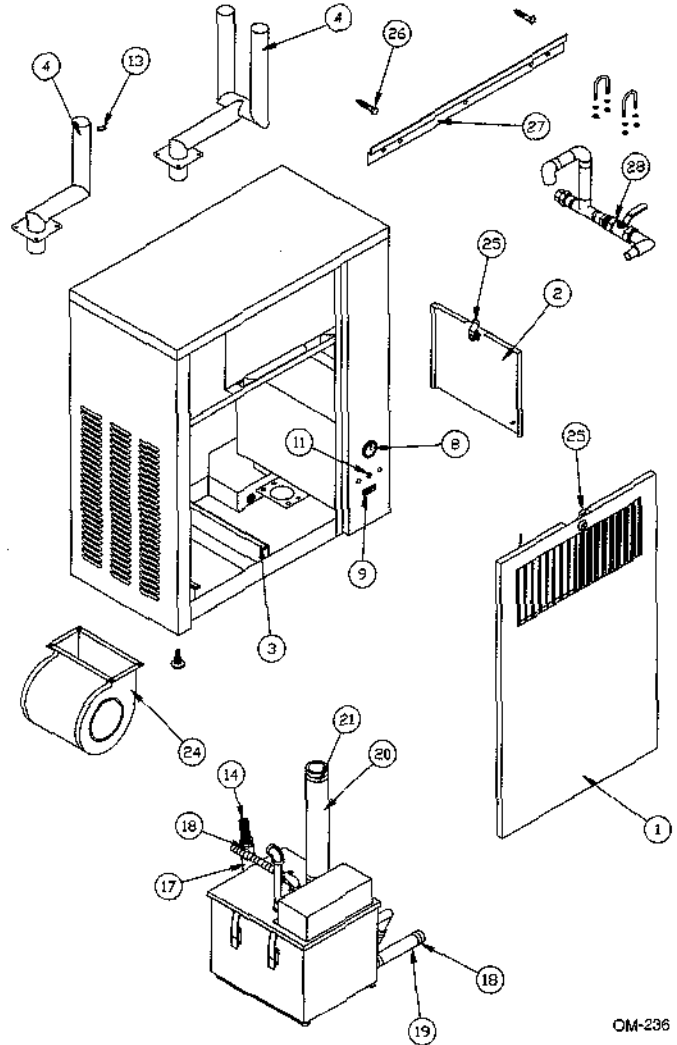

VAPORFAN DI Vaporizing Tank

No.	Description	Qty.	Part No.
29	Vaporizer Tank (VFDI 20, 40)	1	160010-001
29	Vaporizer Tank (VFDI 60, 85, 100, 120)	1	160010-002
33	Thermo Cut-Out	1	409560-001
34	Heater Terminal Cover (VFDI 20, 40)	1	160110-001
34	Heater Terminal Cover (VFDI 60, 85, 100, 120)	1	160110-002
35	Cover Gasket (VFDI 20, 40)	1	309950-001
35	Cover Gasket (VFDI 60, 85, 100, 120)	1	309950-002
37	Heater	1*	
38	Rubber Stopper	1	30960
39	Utility Knob	4	700725
40	Vaporizer Cover (VFDI 20)	1	160200-001
40	Vaporizer Cover (VFDI 40)	1	160200-002
40	Vaporizer Cover (VFDI 60)	1	160201-001
40	Vaporizer Cover (VFDI 85, 100, 120)	1	160201-002
41	Float Switch	1	408420
42	Float Valve Assembly	1	505220
43	Fill Valve Tube	1	160210
44	1/4" 90° Elbow - SST	1	200580
45	Fill Valve Orifice - DI (.041)	1	160225-001
46	1/4" NPT Seal Ring	1	306365

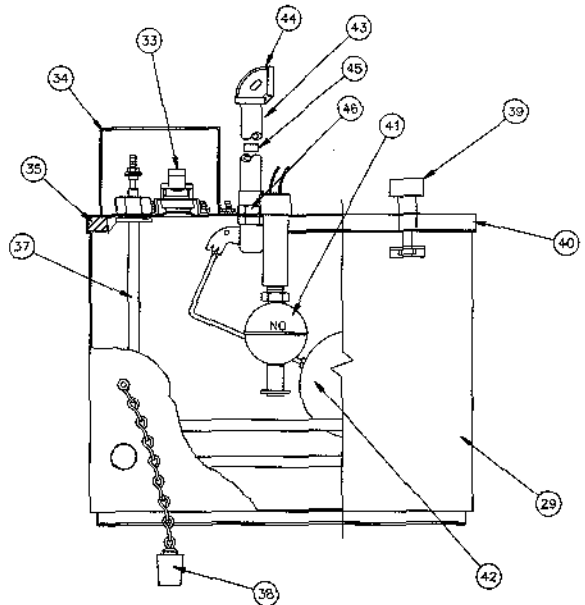

OM-236

OM-243

1* - Refer to specific order for quantity and type.

2 -YEAR LIMITED WARRANTY

DRI-STEEM Humidifier Company (DRI-STEEM) warrants to the original user that its products will be free from defects in materials and workmanship for a period of two (2) years after installation or twenty-seven (27) months from the date DRI-STEEM ships such product, whichever date is the earlier.

If any DRI-STEEM product is found to be defective in material or workmanship during the applicable warranty period, DRI-STEEM's entire liability, and the purchaser's sole and exclusive remedy, shall be the repair or replacement of the defective product, or the refund of the purchase price, at DRI-STEEM's election. DRI-STEEM shall not be liable for any costs or expenses, whether direct or indirect, associated with the installation, removal or re-installation of any defective product.

DRI-STEEM's limited warranty shall not be effective or actionable unless there is compliance with all installation and operating instructions furnished by DRI-STEEM, or if the products have been modified or altered without the written consent of DRI-STEEM, or if such products have been subject to accident, misuse, mishandling, tampering, negligence or improper maintenance. Any warranty claim must be submitted to DRI-STEEM in writing within the stated warranty period.

DRI-STEEM's limited warranty is made in lieu of, and DRI-STEEM disclaims all other warranties, whether express or implied, including but not limited to any IMPLIED WARRANTY OF MERCHANTABILITY, ANY IMPLIED WARRANTY OF FITNESS FOR A PARTICULAR PURPOSE, any implied warranty arising out of a course of dealing or of performance, custom or usage of trade.

DRI-STEEM SHALL NOT, UNDER ANY CIRCUMSTANCES BE LIABLE FOR ANY DIRECT, INDIRECT, INCIDENTAL, SPECIAL OR CONSEQUENTIAL DAMAGES (INCLUDING, BUT NOT LIMITED TO, LOSS OF PROFITS, REVENUE OR BUSINESS) OR DAMAGE OR INJURY TO PERSONS OR PROPERTY IN ANY WAY RELATED TO THE MANUFACTURE OR THE USE OF ITS PRODUCTS. The exclusion applies regardless of whether such damages are sought based on breach of warranty, breach of contract, negligence, strict liability in tort, or any other legal theory, even if DRI-STEEM has notice of the possibility of such damages.

By purchasing DRI-STEEM's products, the purchaser agrees to the terms and conditions of this limited warranty.

DRI STEEM[®] HUMIDIFIER COMPANY



14949 Technology Drive • Eden Prairie, MN 55344
Phone: (612) 949-2415 • Fax: (612) 949-2933
E-Mail: sales@dristeem.com • Web: www.dristeem.com

International Office:

Bell Place, Bell Lane • Syresham, Brackley • NN13 5HP, U.K.
Phone: +44 1280 850122
Fax: +44 1280 850124
E-Mail: 106277.1443@compuserve.com



Printed on recycled paper.
Minimum 10% post-consumer waste.

Continuous product improvement is a policy of DRI-STEEM Humidifier Company. Therefore, product features and specifications are subject to change without notice.

DRI-STEEM and VAPORFAN are Registered Trademarks of the DRI-STEEM Humidifier Company.
TEFLON is a Registered Trademark of DuPont.