

Read and save these instructions!

VAPOR-LOGIC[®]₃

Microprocessor-based humidifier control system

Installation and operation manual



DRISTEEM
HUMIDIFIER COMPANY

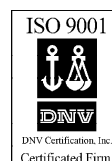



PLEASE: read this manual!

This manual will guide you through installation, operation and maintenance procedures for your new VAPOR-LOGIC[®]₃ microprocessor-based humidifier control system. Proper installation and operating practices will ensure years of trouble-free service.

For information about your humidifier tank or dispersion unit, please see the manuals for those specific products.

For technical support, contact your DRI-STEEM distributor or call +44 1280 850122 or fax +44 1280 850124. If you have questions, first review Pages 54-70, which describe typical problems and solutions, and also list information you will need to give us if you call.

**Visit our web site:
www.dristeem.com**

For information about other DRI-STEEM products, visit our web site, or contact us using the information listed below.



Corporate headquarters

14949 Technology Drive • Eden Prairie, MN 55344
952-949-2415 • 800-328-4447 • 952-229-3200 (fax)
106277.1443@compuserve.com (e-mail)

European office

Bell Place, Bell Lane • Syresham, Brackley • NNN13 5HP, UK
+44 1280 850122 • +44 1280 850124 (fax)
106277.1443@compuserve.com (e-mail)

VAPOR-LOGIC[®]₃ table of contents.

Product overview

Features summary	1-2
Circuit board diagram	3
Main control board connections	4-6
Expansion board connections	7
Program code nomenclature	8-9
Warranty	10

Installation

Installation checklist	11
Proper wiring procedures	12-13
Control cabinet installation and wiring	14
Keypad/display installation	15
Sensing devices installation (general)	16-20
VAV sensing device installation	21
Temp comp sensing device installation	22
Changing control input	23

Operation

Start-up checklist	24-25
Keypad/display overview	26
Menu structure	27
“Set Up” menu information	28
Keypad/display readouts	29
Main menu items explained	30-36
Control modes	37
Modulation types	38-40
Adjusting set point	41
PID tuning	42-43
VAV, temp comp, dew point control	44
Heat-up, SDU timer, offsets, metric conversion	45
Conductivity probe	46
Float valve	47
Drain, flush, skim functions	48
Maintenance interval, EOS, date set	49
Safety features	50
Fault messages, diagnostics	51-52
Reports, multiple tank systems	53
Troubleshooting	54-75
Replacement Parts	76
Notes	77-79

VAPOR-LOGIC[®]₃ features overview.

Accurate, responsive microprocessor control

Our newest controller, VAPOR-LOGIC₃, provides unprecedented, comprehensive control for DRI-STEEM humidifiers. With expanded capabilities, easy-to-use keypad, and modular, open protocol design, the VAPOR-LOGIC₃ efficiently controls all humidifier functions.

Navigating the keypad to adjust or review humidifier functions is an intuitive process of walking through easily-read screen menus. The controller's open-protocol design allows seamless integration with building management systems.

You will find no other controller in the humidifier market able to provide such functionality, ease of use, and accurate RH control.

Control mode options

- **On-off operating mode** controls single or multiple electric staged outputs.
Expected accuracies: $\pm 5-7\%$ RH
- **Time proportioning function** controls humidifier outputs via cyclic actions on electrical contactors or a modulated signal to our solid state zero cross-fired SSR power controllers.
Expected accuracies:
 - Contactor action: $\pm 2-4\%$ RH
 - SSR action: $\pm 1-3\%$ RH
- **Proportional action** controls modulating steam or hot water valves or GTS burners by providing a linear analog signal to the motors (for STS, LTS or GTS humidifiers).
Expected accuracies: $\pm 2-5\%$ RH

More on next page ...

VAPOR-LOGIC[®]₃ features overview.

Summary of features

- **PID control** provides the most accurate, responsive and adjustable relative humidity (RH) control.
- **Self-diagnostic test at start-up**
- **End of season auto-drain**
- **Real-time clock** allows time-stamped alarm tracking, and three ways to program drain and flush cycles:
 1. Usage (after a set number of kg have cycled through)
 2. Usage and time (set number of kg plus defined period of time)
 3. Scheduled intervals
- **Redesigned keypad** has an intuitive interface with backlit display and provides:
 - menu-driven access to all system functions
 - default screen for quick view of system status and set points
 - data reports to track performance and efficiency
 - system diagnostics and alarm tracking for troubleshooting
 - single-point multiple-humidifier control without an additional system controller
 - password protection of setup parameters
 - wall-mounting with a standard telephone plate, flush mounting, or hand-held options
- **Tank temperature sensor:**
 - preheats tanks for uninterrupted operation
 - senses for freeze protection
 - senses for low water/over temperature protection
- **Sensitivity to low-conductivity water** (important when using a standard humidification system with low-mineral-content water)
- **Uses Echelon's LonTalk[®]**, an open communications protocol used by most major control companies, allowing full interaction with building management systems
- **Single-controller platform; modular design**

The new VAPOR-LOGIC₃ controller will soon be standard on all DRI-STEEM humidifiers. The base configuration includes a main controller board and keypad. Expansion modules will increase capability, thereby allowing all systems to use the same controller platform and keypad interface.
- **Year-2000 compliant**

Product overview

VAPOR-LOGIC[®]₃ circuit board.

Figure 3-1: VAPOR-LOGIC₃ printed circuit board

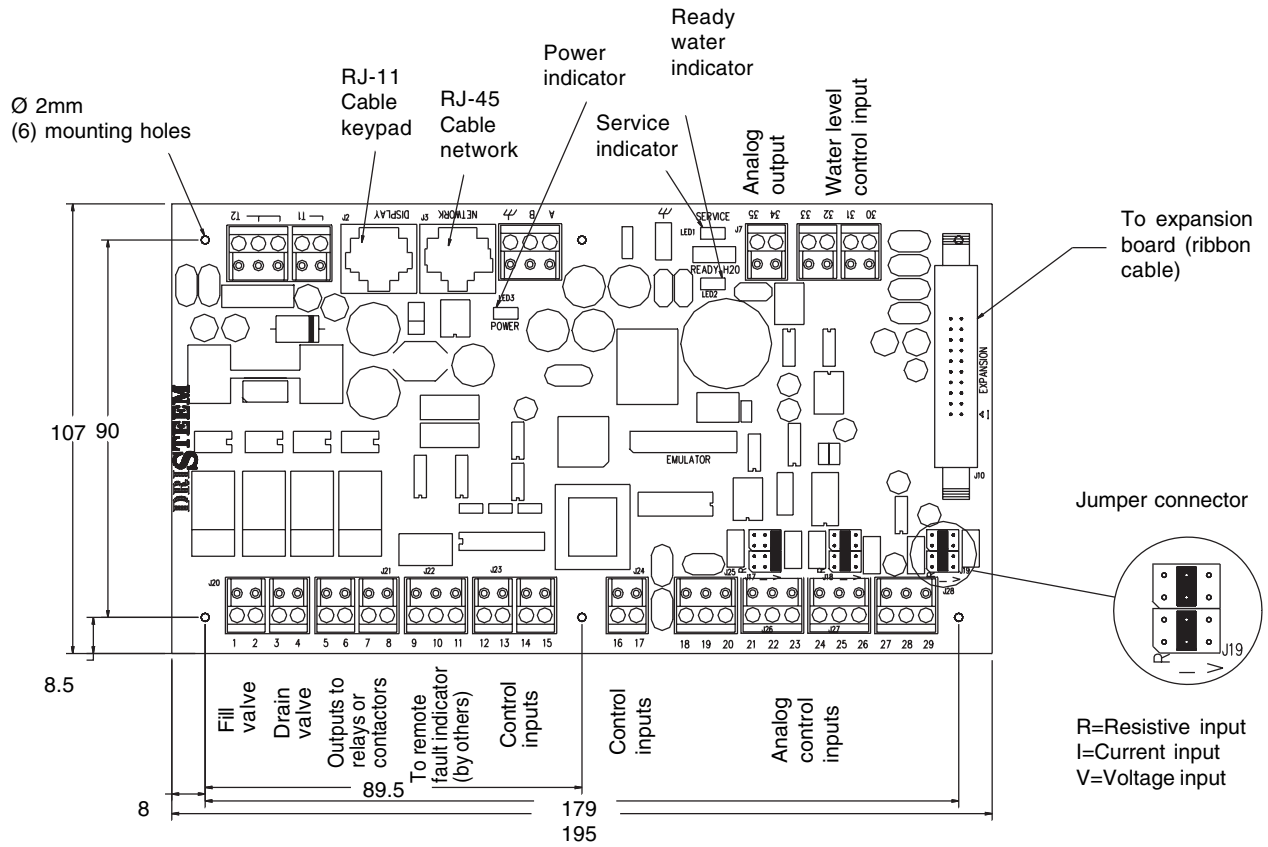

OM-VL3-3

Main control board connections.

VAPOR-LOGIC₃ main control board connections

- J1** Wire terminal supplies 24 VAC to power the VAPOR-LOGIC₃ control board.
 - Double terminal T1 – 24 VAC, 10 VA maximum load
 - Triple terminal T2 – 24 VAC common
- J2** RJ11 female modular jack connection for supply voltage and FTT-10A communication to keypad/display
- J3** RJ45 female modular jack connection for FTT-10A communication to LonTalk[®] network
- J4** Wire terminal connection for FTT-10A communication to LonTalk network. Terminals A and B provide the communication lines. The last terminal is earth ground.
- J5** End of line communication terminator pins
- J6** Push-on connector for earth ground
- J7** 0-15 VDC analog output, typically connected to the input of a steam or hot water valve. Terminal 34 is the positive output signal and terminal 35 is common.

- J8** Connector receives necessary continuity input signals from water detection devices:
 - Probe system water level detection
 - Terminal 30 detects maximum water level from top probe rod and brown plug wire.
 - Terminal 31 detects water level at refill point from middle probe rod and orange plug wire.
 - Terminal 32 detects water level at its lowest point from lower probe rod and purple plug wire.
 - Terminal 33 is the common return path for all water detection rods from the humidifier tank machine ground back to VAPOR-LOGIC₃ control.
 - DI/RO system detection
 - Terminals 30 and 31 are not used.
 - Terminal 32 is connected to the humidifier tank low water float switch (normally open).
 - Terminal 33 is the return signal from the float switch to VAPOR-LOGIC₃ control via machine ground.
- J10** Ribbon cable connector for VAPOR-LOGIC₃ expansion modules

More on next page ...

Main control board connections (cont.).

Main control board connections (cont.)

 Important note about J17, J18 and J19:

All connection diagrams show connector shunts on J17, J18 and J19. The connector shunts and appropriate software have been selected by DRI-STEEM based on original customer orders. **Field changing the input connector shunts will require control input modification: See Page 23 “Changing Control Input.”**

J17 Jumper pins determine the configuration of the type of input control into the RH sensor input (terminals 21 through 23) for wire terminal connector J26.

- R = Resistance, 0-150 Ohms range
 - Used with on-off humidistats, staging switches, PE switches
 - Used with analog 0-150 Ohm input device (pneumatic transducer or humidistat)
- I = MilliAmp, 0-20 mA range
 - Used with any humidity sensor with 4-20 mA output
 - Used with any computer or energy management system with 4-20 mA output
 - Internal resistance 249 Ohms, terminal 22 proportional signal, terminal 23 signal ground
- V = Volts DC, 0-15 volt range
 - Used with any control humidistat 0-15V DC
 - Terminal 21 provides positive 21 VDC supply, terminal 22 proportional signal, terminal 23 signal ground

J18 Identical to J17 input selector pins except used to configure duct high limit RH input (terminals 24 through 26) for wire connector terminal J27

J19 Identical to J17 input selector pins except used to configure window temperature sensor input (terminals 27 through 29) for wire connector terminal J28

J20 Wire terminal connector supplies 24 VAC voltage via terminals 1 and 2 to the fill valve and via terminals 3 and 4 to the drain valve.

J21 Wire terminal connector supplies 24 VAC voltage via terminals 5 and 6 to the power contactor and via terminals 7 and 8 to the SDU relay.

J22 Wire terminal connection allows for remote fault indication. Relay closure is provided (1 A max.).

More on next page ...

Main control board connections (cont.).

Main control board connections (cont.)

J23 Wire terminal connection provides optically isolated connection to air flow proving switch and safety circuit. Terminal 12 supplies 24 VAC to proving switch circuit, SPST, which closes when air flow is present. Terminal 13 is the return connection from the proving switch into the VAPOR-LOGIC₃ control. Terminal 14 supplies 24 VAC to safety circuit, SPST, which is closed under normal operating conditions. Terminal 15 is the return connection from the safety circuit into the VAPOR-LOGIC₃ control.

J25 Wire terminal connector provides input for RTD tank temperature sensor. Terminal 19 supplies 21 VDC to temperature sensor. Terminal 20 is the return connection from the temperature sensor into the VAPOR-LOGIC₃ control. Terminal 18 has no connection.

J26 Wire terminal connector receives the necessary signal from the controlling RH sensor.

- Terminal 21: Positive polarity 21 VDC supply (25 mA max)
- Terminal 22: Control signal
- Terminal 23: Signal ground
- Input selector pin J17 configures J26 input

J27 Wire terminal connector receives the necessary signal from the duct high limit RH sensor.

- Terminal 24: Positive polarity 21 VDC supply (25 mA max)
- Terminal 25: Control signal
- Terminal 26: Signal ground
- Input selector pin J18 configures J27 input

J28 Wire terminal connector receives the necessary signal from the window temperature sensor.

- Terminal 27: Positive polarity 21 VDC supply (25 mA max)
- Terminal 28: Control signal
- Terminal 29: Signal ground
- Input selector pin J19 configures J28 input

Expansion board connections.

GTS® and VAPORSTREAM® expansion board connections

- J1** Push-on connector for earth ground
- J2** Blower No. 2 control:
- Terminal 21: Positive polarity 21 VDC supply (25 mAmax)
 - Terminal 22: Blower tachometer feedback
 - Terminal 23: PWM output to blower
 - Terminal 24: Common
- J3** Blower No. 1 control:
- Terminal 17: Positive polarity 21 VDC supply (25 mAmax)
 - Terminal 18: Blower tachometer feedback
 - Terminal 19: PWM output to blower
 - Terminal 20: Common
- J5** Ribbon cable connector for VAPOR-LOGIC³ main controller connection
- J6** Ribbon cable connector for additional VAPOR-LOGIC₃ expansion modules
- J7** Wire terminal supplies 24 VAC to power the VAPOR-LOGIC₃ expansion module.
- Terminal T1 – 24 VAC, 10 VA maximum load
 - Terminal T2 – 24 VAC common
- J8** Wire terminal connector supplies 24 VAC voltage with terminal pairs 1 and 2, 3 and 4, and 5 and 6 to either contactors or GTS ignition controllers. (Terminals 1, 3 and 5 supply the 24 VAC. Terminals 2, 4 and 6 provide the 24 VAC common.)
- J9** Wire terminal connection provides optically isolated connections for the gas valve feedback. Terminals 7 and 9 provide 24 VAC and are not used. Terminal 8 receives a 24 VAC signal back from gas valve No. 1. Terminal 10 receives a 24 VAC signal back from gas valve No. 2.
- J10** Wire terminal connection provides optically isolated connections for the combustion air damper limit switch, power vent pressure switch and flue differential pressure switch. Terminal 11 supplies 24 VAC to the combustion air damper limit switch, which closes when the damper has opened. Terminal 12 is the return connection from the limit switch into the VAPOR-LOGIC₃ expansion module. Terminal 13 supplies 24 VAC to the power vent pressure switch which closes when the fan has started. Terminal 14 is the return connection from the pressure switch into the VAPOR-LOGIC₃ expansion module. Terminal 15 supplies 24 VAC to the flue differential pressure switch which closes when the blowers have started. Terminal 16 is the return connection from the differential pressure switch into the VAPOR-LOGIC₃ expansion module.

Program code nomenclature.

Program code explained

A 14-digit VAPOR-LOGIC₃ program code appears on the front of the control cabinet and on the wiring diagram inside the control cabinet. The program code specifies the parameters of the VAPOR-LOGIC₃ microprocessor, which controls your humidification system. An explanation of the program code is detailed below.

VAPOR-LOGIC₃ program code

A. Type of units:

E = English
M = Metric

B. VAPOR-LOGIC₃ system type:

G = GTS®
S = STS®
L = LTS®
V = VAPORSTREAM®
M = VAPORMIST®
C = CRUV®
U = ULTRA-FOG®
N = Steam Injection

C. VAPOR-LOGIC₃ board classification:

1 = One-tank system
2 = Two-tank system
3 = Three-tank system
4 = Four-tank system
5 = Five-tank system
6 = Six-tank system

D. Digital display/keypad features:

1 = Single keypad

E. Type of outputs (0-4):

0 = Steam valve/100% SSR
1 = One heat stage
2 = Two heat stages
3 = Three heat stages
4 = Four heat stages

F. System kilos output:

= Output capacity
(e.g., 00128 = output capacity in kg/hr)

G. Type of water level control:

D = DI w/ manual drain
E = DI w/ end of season drain
M = Standard w/ manual drain
A = Standard w/ autodrain

H. Operating mode:

1 = Single staged
2 = Externally staged
6 = GTS
7 = TP
8 = SSR
9 = Steam valve

I. VAV options:

V = Option present
O = Option not selected
S = SDU option

J. Temperature compensation options:

T = Option present
O = Option not selected

K. Type of humidity sensing device:

N = None, for on/off
C = 0-135 Ohm humidistat
D = 6-9 VDC humidistat
H = 0-10 VDC humidistat
E = 4-20 mA humidistat
X = 4-20 mA transmitter
Q = Dew point transmitter
S = Special

Program code nomenclature.

Program code example

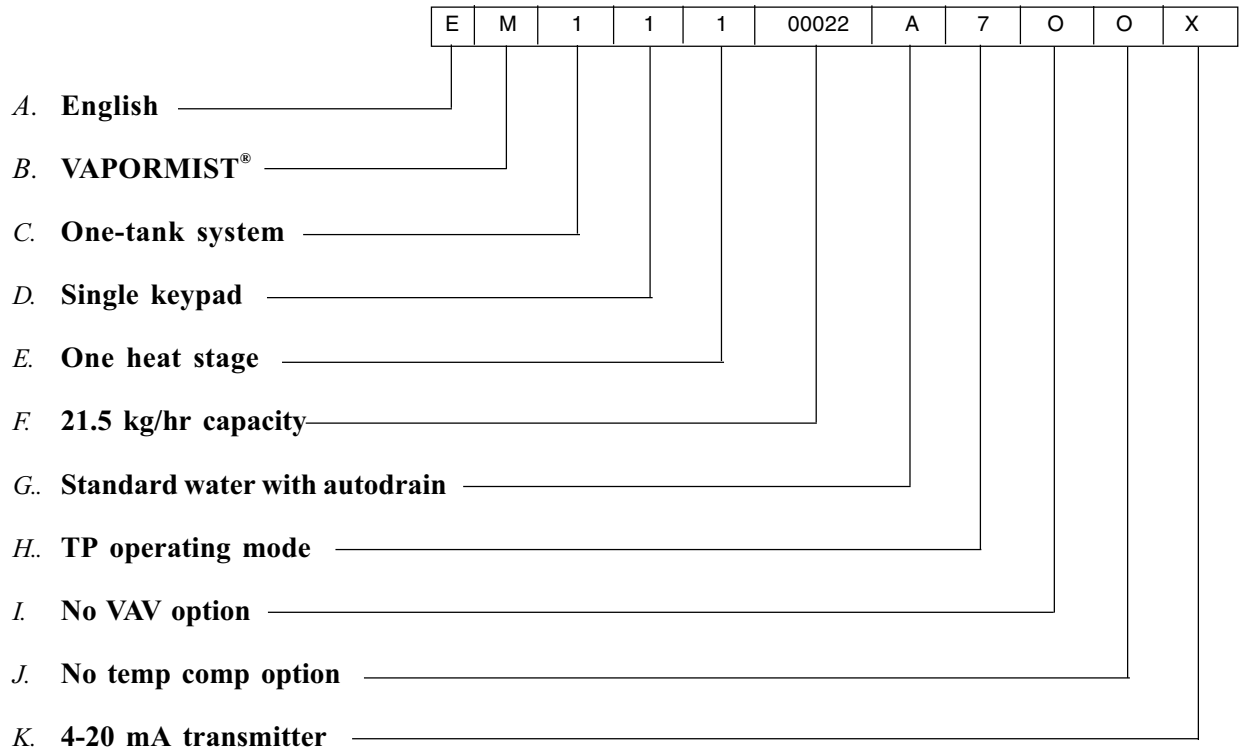

Two-year limited warranty.

DRI-STEEM Humidifier Company (“DRI-STEEM”) warrants to the original user that its products will be free from defects in materials and workmanship for a period of two (2) years after installation or twenty-seven (27) months from the date DRI-STEEM ships such product, whichever date is the earlier.

If any DRI-STEEM product is found to be defective in material or workmanship during the applicable warranty period, DRI-STEEM’s entire liability, and the purchaser’s sole and exclusive remedy, shall be the repair or replacement of the defective product, or the refund of the purchase price, at DRI-STEEM’s election. DRI-STEEM shall not be liable for any costs or expenses, whether direct or indirect, associated with the installation, removal or re-installation of any defective product.

DRI-STEEM’s limited warranty shall not be effective or actionable unless there is compliance with all installation and operating instructions furnished by DRI-STEEM, or if the products have been modified or altered without the written consent of

DRI-STEEM, or if such products have been subject to accident, misuse, mishandling, tampering, negligence or improper maintenance. Any warranty claim must be submitted to DRI-STEEM in writing within the stated warranty period.

DRI-STEEM’s limited warranty is made in lieu of, and DRI-STEEM disclaims all other warranties, whether express or implied, including but not limited to any IMPLIED WARRANTY OF MERCHANTABILITY, ANY IMPLIED WARRANTY OF FITNESS FOR A PARTICULAR PURPOSE, any implied warranty arising out of a course of dealing or of performance, custom or usage of trade.

DRI-STEEM SHALL NOT, UNDER ANY CIRCUMSTANCES, BE LIABLE FOR ANY DIRECT, INDIRECT, INCIDENTAL, SPECIAL OR CONSEQUENTIAL DAMAGES (INCLUDING, BUT NOT LIMITED TO, LOSS OF PROFITS, REVENUE OR BUSINESS) OR DAMAGE OR INJURY TO PERSONS OR PROPERTY IN ANY WAY RELATED TO THE MANUFACTURE OR THE USE OF ITS PRODUCTS. The exclusion applies regardless of whether such damages are sought based on breach of warranty, breach of contract, negligence, strict liability in tort, or any other legal theory, even if DRI-STEEM has notice of the possibility of such damages.

By purchasing DRI-STEEM’s products, the purchaser agrees to the terms and conditions of this limited warranty.

Installation checklist.

Before installing your VAPOR-LOGIC[®]₃ control system, review this checklist to ensure proper installation of the product. Failure to follow the recommendations listed below could result in failure or damage to the humidifier or microprocessor.

- Read this manual and information before starting.
- See wiring diagram and information located inside the control cabinet door. Return all information to the control cabinet after installation.
- Position the control cabinet so that it is in sight of the humidifier tank.
- Position the control cabinet so that the **wire length from the control cabinet to the humidifier is 15 m or less.**
- Connect an approved electric earth ground to the earth ground lug in the control cabinet.
- Never route the low voltage field control wires near the line voltage section of the control cabinet or in the same conduit as line voltage wires.
- Never use shielded cable for water level probe wiring.
- Attach the heater/machine ground lug in the junction box, on the humidifier, to the subpanel machine ground lug with the appropriate wire, sized according to local regulations.
- Use 2-wire, 1 mm² shield plenum nonconduit-rated cable with drain wire for all humidity and temperature sensor wiring. (Use Belden Company cable No. 88760 or equivalent; see wiring diagram for appropriate connections.)
- Never ground shield at sensor end.** A shield grounding lug is provided on the control cabinet subpanel to ground the cable shielding.
- Keypad installation precautions:
 - Do not locate keypad inside control cabinet.
 - Route modular cable within control cabinet separated from line voltage circuits.
- Verify that VAPOR-LOGIC₃ program code**, which is detailed on Pages 8 and 9 of this manual, matches field requirements.

Proper wiring procedures.

Proper wiring prevents electrical noise

Electrical noise can produce undesirable effects on electronic control circuits, thereby affecting controllability. Electrical noise is generated by electrical equipment, such as inductive loads, electric motors, solenoid coils, welding machinery, or fluorescent light circuits. The electrical noise or interference generated from these sources (and the effect on controllers) is very difficult to define, but the most common symptoms are erratic operation or intermittent operational problems.

Most noise problems can be prevented by using proper wiring practices and techniques to prevent coupling or inducing of electrical interference into control circuits. The following simple wiring practices should minimize interaction of noise and controls:

- Connect humidifier and control cabinets to a code-approved earth ground.
- Separate the line voltage wiring from low voltage control circuit wiring when routing electrical wiring inside the control cabinet.
- Use separate electrical conduits for line and low voltage control wiring from the humidifier to humidity sensors, airflow switches, etc.

More on next page . . .

Proper wiring procedures (cont.).

Proper wiring prevents electrical noise (cont.)

- Do not use chassis or safety grounds as current-carrying commons. No safety grounds should ever be used as a conductor or neutral to return circuit current.
- When wiring external electrical connections to humidistats, room/duct humidity and temperature transmitters, or control signal input connections from a building control system, use 1 mm² (minimum) plenum-rated twisted-pair wire, Belden No. 88760, with cable shielding and drain wire for grounding.
- Return all shielded cable connections to the control cabinet for grounding. Do not ground shield at the device end.
- **⚠IMPORTANT:** Locate the control cabinet so that wire lengths are 15 m or less to the humidifier.
- Use 1 mm² stranded wire run in conduit (see Figure 13-1) for probe and low-water cut off wiring.
- **⚠IMPORTANT:** Do not use shielded cable for probe wiring.

Figure 13-1: Probe wiring

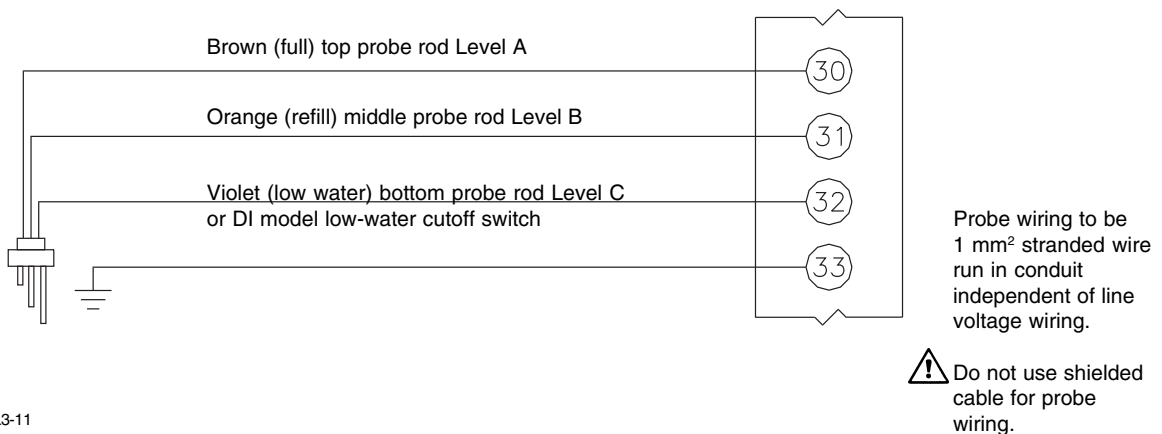

OM-VL3-11

Control cabinet installation and wiring.

The VAPOR-LOGIC₃ control board is shipped mounted with all internal wiring completed within a control cabinet. All software has been custom programmed into your VAPOR-LOGIC₃ system according to the original order requirements.

Important control cabinet installation points:

- All humidifier power wiring is represented on the humidifier wiring diagram located with an installation guide on the inside of the control cabinet door. Return all instructions to the control cabinet after installation.
 - Refer also to the VAPOR-LOGIC₃ control board drawing on Page 3 of this manual for detail of the board and connection points.
 - Pick a location within sight of the humidifier tank that will allow for easy access to the control cabinet and internal electrical components.
-  **IMPORTANT:** Locate the control cabinet so that wire lengths are 15 m or less to the humidifier.
- Mount control cabinet using the mounting tabs.
 - Always wire the VAPOR-LOGIC₃ control board per local and national electric codes.
 - VAPOR-LOGIC₃ is powered by a low voltage Class

2 control transformer. The transformer provides a 24 VAC supply, and is protected by an integral manual reset circuit breaker.

- Follow field wire torque requirements shown on the humidifier wiring diagram when connecting the power and control wiring inside the humidifier control cabinet.
- Use only a 3 mm straight blade screwdriver on VAPOR-LOGIC₃ control board terminal blocks.
- Use a single 1 mm² pre-tinned wire in each terminal at the VAPOR-LOGIC₃ terminal block. Torque to 0.5 Nm.
- When terminating multiple wires to the VAPOR-LOGIC₃ control board terminal block, secure the multiple wires and one additional wire with an appropriately sized wire nut. Use the single additional wire's opposite end to connect to the VAPOR-LOGIC₃ terminal block.
- Never run the control system wires bundled with, or in the same conduit as, power wires.

Keypad/display installation.

Installing modular cable

⚠️IMPORTANT: When routing modular cable inside the control cabinet, route cable away from all power wiring and connect the male modular plug into the VAPOR-LOGIC₃ printed circuit board-mounted female modular receptacle, J2. Push male plug in until you hear a “click.” (The cable should be plugged into the keypad/display as well.) The six-wire cable provides the AC power to the keypad/display and completes the FTT-10A-type digital communication between the keypad/display and the VAPOR-LOGIC₃ control board.

⚠️CAUTION: If a longer cable is needed, do not attempt to fabricate one. Improper wiring can permanently damage the VAPOR-LOGIC₃ board, keypad or display. Please contact your local DRI-STEEM representative for longer cable options.

Installing the keypad/display

⚠️IMPORTANT: Do not locate the keypad/display inside the control cabinet. The hardware is premounted in the keypad/display case with front access to the digital display and keypad. Position the case in a convenient location for easy access.

Note that the keypad/display requires an ambient temperature range of 0°C to 50°C to operate properly. Exceeding these limits will result in a poor reading or no reading at all.

Sensing devices and humidity control.

Important to properly place sensing devices

Humidity sensing devices must be properly placed to achieve accurate humidity control. A typical small air handling system is shown in the drawings on Pages 17 and 18 (Figures 17-1 and 18-1). For the best control, place the humidity sensing device in the center of a room, or just inside the return air duct (location “A”). These locations will provide the least amount of variation caused by air flow patterns and room temperature. Placement of the duct humidity sensing device within the outlet of the air handler (location “D”) is ideal for duct high limit control, but the actual placement must be downstream from dispersion tubes a sufficient distance to ensure steam absorption has taken place. Accurate control of temperatures in rooms and ducts is also very important to improve control of relative humidity.

Other factors that affect humidity control

Unsatisfactory humidity control may involve more than just the controller’s capability to control the system. Other factors that play an important role in overall system control are:

- Size of the humidification system relative to load
- Overall system dynamics associated with moisture migration time lags
- Accuracy of humidistats and humidity transmitters and their location
- Dry bulb temperature accuracy in space or duct
- Velocities and air flow patterns in ducts and space environments
- Electrical noise or interference

Installation

System Diagram.

Figure 17-1: System diagram

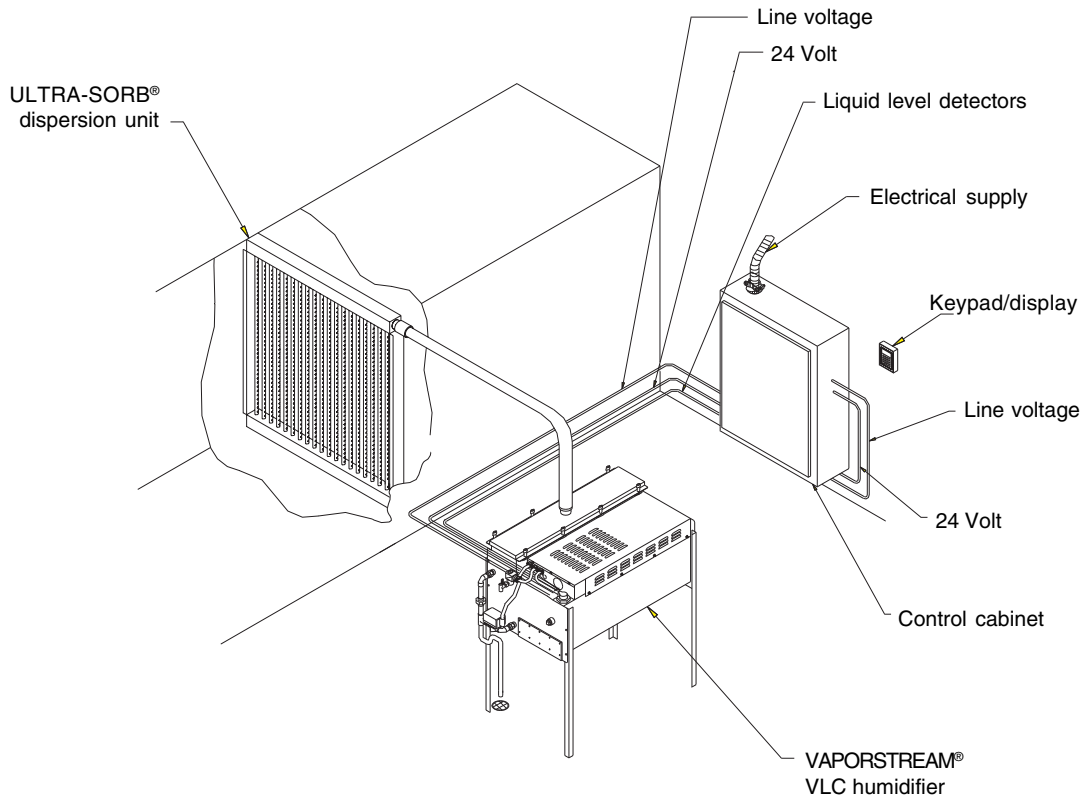

OM-3007

Installation

Placement of sensing devices.

Figure 18-1: Recommended sensor locations

- A Best
- B Alternative location
- C Not recommended
- D Best duct high limit humidistat

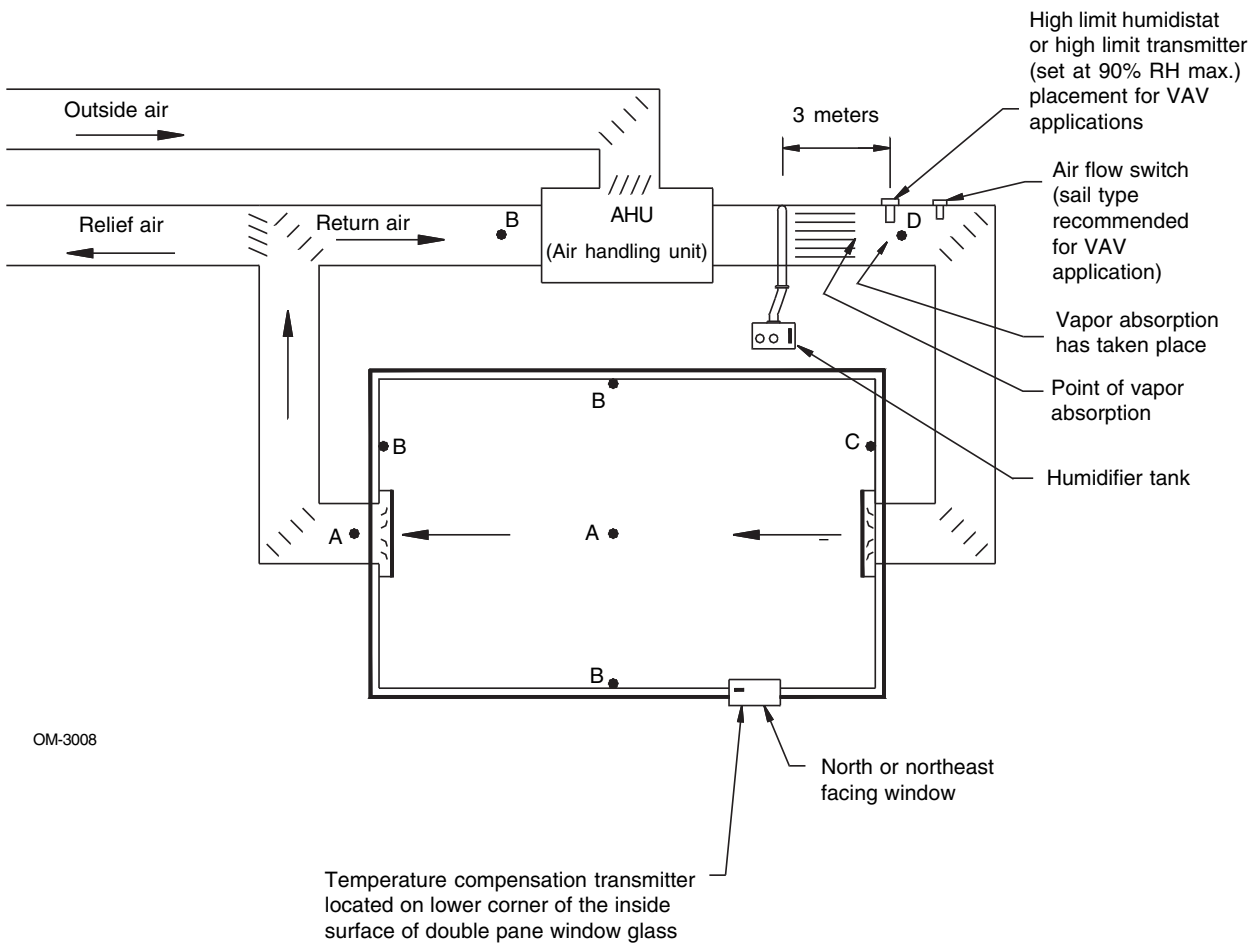

OM-3008

Wiring of sensing devices.

Wiring on-off humidistats

DRI-STEEM provides three types of on-off controls: wall-mounted humidistat, duct-mounted humidistat, or pneumatic/electric relay. The wiring diagram (found on the inside of the humidifier control cabinet) will show proper wiring for these controls.

Wiring modulating humidistats

The signal from a humidistat directly controls the amount of output from the humidifier. The standard modulating humidistat controllers DRI-STEEM provides are either duct or wall-mounted.

The humidistats are powered by a 21 VDC supply provided by the VAPOR-LOGIC₃ control board. A variable control signal is returned to provide the modulating function on the humidifier.

For a pneumatic modulating signal, DRI-STEEM may provide a transducer, which accepts a 21-138 kPa pneumatic input range.

Wiring modulating humidity or temperature transmitters

Transmitters provide an analog signal proportional to the process variable being measured. All transmitters provided by DRI-STEEM are two-wire devices. (See your wiring diagram for proper connections.) The humidity transmitters have a range of 0-100% RH with an output of 4-20 mA. The temperature transmitter has a range of -29° to 71°C with a 4-20 mA output.

Calculation of transmitter % RH

$$\% \text{ RH} = \frac{(\text{milliAmp reading minus } 4)}{.16}$$

Example: $\frac{12 \text{ mA} - 4}{.16} = 50\%$

Wiring of sensing devices.

Figure 20-1: Example of proper shielding techniques when connecting humidity or temperature devices to VAPOR-LOGIC³ control inputs

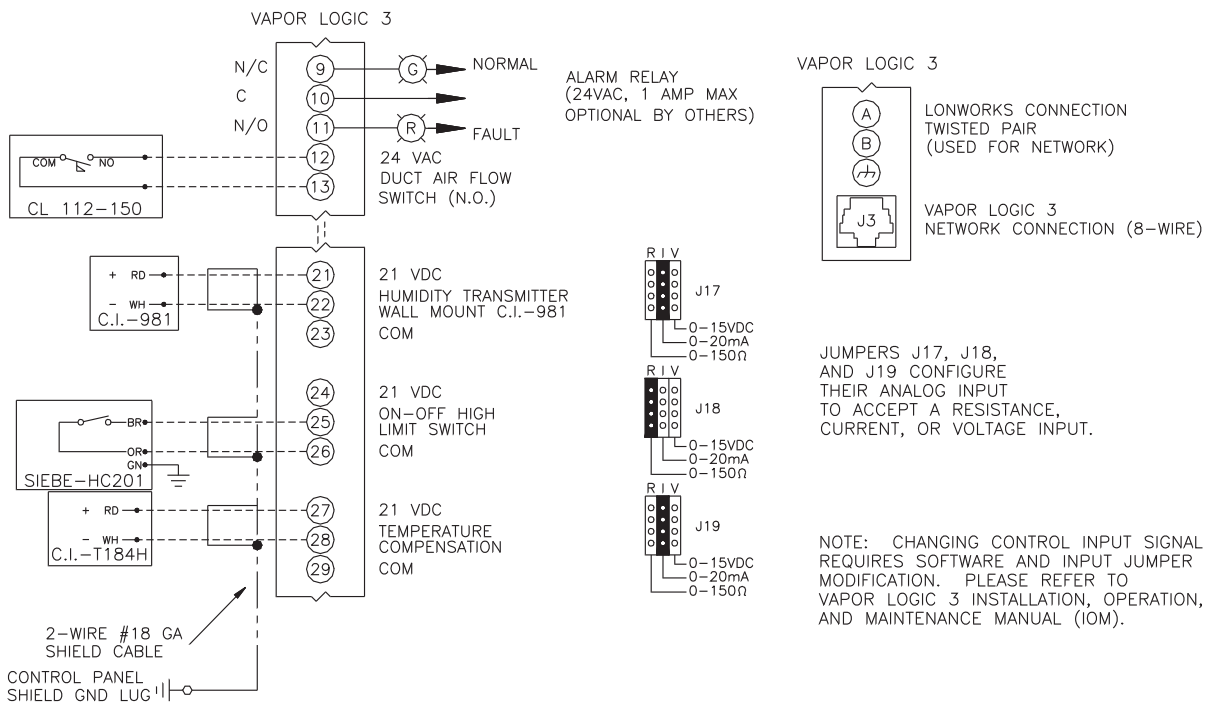

Note: The wiring diagram (found on the inside of the humidifier control cabinet) will show the proper controls wiring.

OM-VL3-17

! IMPORTANT: Consult control cabinet wiring diagram. Control changes require wiring and programming changes.

Installation

Wiring VAV sensing device.

Variable air volume (VAV) option

This option is identified as a “V” in the third-from-last place of your program code nomenclature (for example: EV11400285A7VOX).

When the VAV control option is requested we provide a duct mounted humidity transmitter (4-20 mA output over 0-100% RH range). Install using shielded cable (see Figure 21-1 below).

The modulating high limit transmitter signal operates in conjunction with the room or duct controlling transmitter signal through the VAPOR-LOGIC₃ control system to prevent over humidification in the duct work. VAPOR-LOGIC₃ will start lowering the humidifier output when the duct relative humidity is within six percent of the duct high limit set point.

When this occurs, the keypad/display will show the message “VAV output limit.” If necessary, the reduction of the humidifier output will continue until maximum high limit set point has been reached, shutting off the humidifier completely.

When the high relative humidity starts to decrease in the duct, VAPOR-LOGIC₃ will slowly start to increase the production of steam vapor. When the duct relative humidity decreases to a point greater than six percent below the duct high limit set point, the control transmitter will be restored as the primary controller and the keypad/display will no longer show the “VAV output limit” text, returning the control system to normal operation.

Figure 21-1: Shielded cable

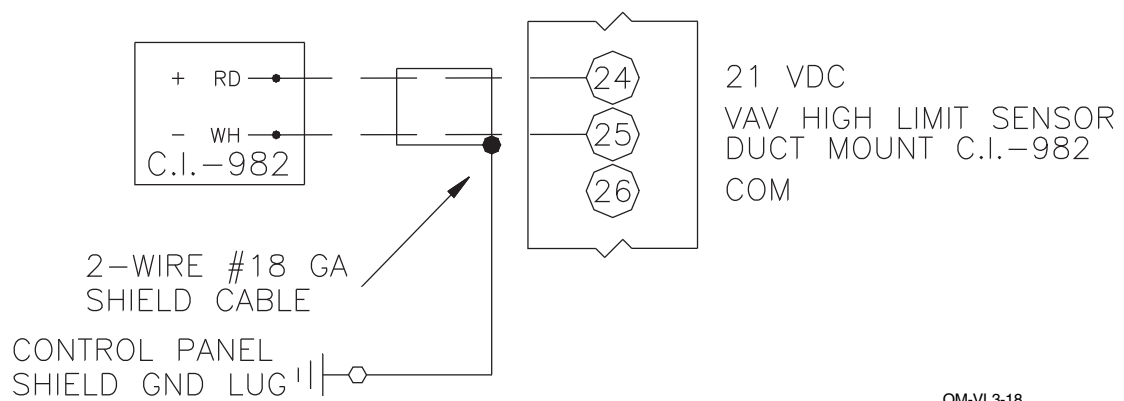

NOTE: Ground shield at control panel end only.
Do not ground shield at device end.

Temperature compensation transmitter.

Temperature compensation offset option

This option is identified as a “T” in the second-from-last place of your program code nomenclature (for example: EV11400285A7OTX).

When selected as an option, DRI-STEEM provides a temperature compensation (temp comp) transmitter. The temperature compensation transmitter continually monitors the interior window glass temperature and transmits this temperature to VAPOR-LOGIC[®]₃. VAPOR-LOGIC₃ then compares the glass temperature to the desired RH set point in the humidified area and calculates the dew point (°C) for the space.

VAPOR-LOGIC₃ will lower (offset) the desired RH set point so that moisture does not form on windows. The keypad/display will show the amount of offset that has taken place as a modified set point. As the interior window glass temperature increases, VAPOR-LOGIC₃ will reduce the offset and restore system control to the normal RH set point for the space.

The transmitter provided with VAPOR-LOGIC₃ is calibrated for -29°C to 71°C with output from 4-20 mA. For example, a temperature reading of 21°C should produce a measurement of 12 mA.

Install using an 1 mm² plenum-rated shielded cable for transmitter wiring with grounding shield at the shield ground lug in the control cabinet (see Figure 21-1 on the previous page).

Temperature compensation transmitter placement

See Figure 22-1 below.

1. Position the temperature compensation transmitter control box on a wall adjacent to a window frame facing north or northeast.
2. Place flat surface of temperature sensor tip on lower corner of glass surface.
3. Temporarily hold the sensor tip in place with strips of masking tape.
4. Apply a small amount of clear RTV silicone adhesive over and around the sensor tip (making sure the sensor tip is in contact with the window glass).
5. After adhesive has cured, remove masking tape.

Figure 22-1: Temperature compensation transmitter placement

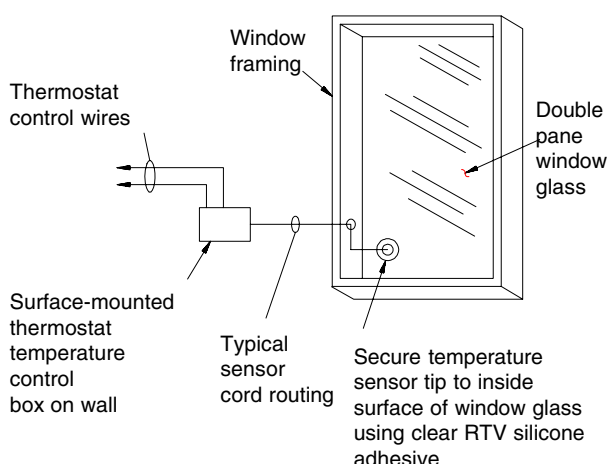

OM-337

Changing control input.

Changing control input

VAPOR-LOGIC₃ has the ability to accept different types of demand signals from either an energy management system or a humidistat. Follow these steps when a signal change is needed:

1. Remove the old signal wires from the board (terminals 21, 22 and 23).
2. Refer to program code nomenclature on Pages 8 and 9. Refer to: “K. Type of humidity sensing device” to identify the new signal that is needed.
3. Enter the “Set Up” screen on the VAPOR-LOGIC₃ keypad and scroll to the “Configuration String” screen.
4. Change the last character in the configuration string to the desired input signal type identified from the program coded nomenclature information on Pages 8 and 9.
5. Adjust the shunt connector J17 to the proper signal type, if necessary:
 - If the signal is current, the jumper should be on I.
 - If the signal is voltage, the jumper should be on V.
 - If the signal is resistance, the jumper should be on R.)
6. Connect the new signal to the board.

Start-up checklist.

Note:

Your humidification system may not have all of the options listed below. If an item does not appear, skip to the next item and continue the process.

- Verify that wiring is done per instructions in this manual and the unit wiring diagram.
- Make sure that the keypad/display is not inside the control cabinet.
- Check water level control voltages. The reading should be 2.5 VAC without water; and 0 VAC with water from ground (Pin 33-J8) to probe inputs (Pins 30, 31 and 32-J8).
- Check the proportional band setting in the “System Set Up” menu of the keypad/display (default is 10%).
- Check the cycle setting in the “System Set Up” menu of the keypad/display (default is 60 seconds; 2 seconds for SSR).
- Check the proportional gain setting in the “System Set Up” menu of the keypad/display (default is 80).
- Check the integral gain setting in the “System Set Up” menu of the keypad/display (default is 40).
- Check the derivative gain setting in the “System Set Up” menu of the keypad/display (default is 0).
- Check drain duration (default is 8 minutes).
- Check flush duration (default is 8 minutes).
- Check RH setting.
- Check control signal.
- Check amp draw of heaters for electric units; refer to wiring diagram for proper rating. If unit is powered by steam, check for steam flow. For gas fired units, verify gas flow and combustion.
- Confirm that the control signal being connected to the VAPOR-LOGIC[®]₃ system is compatible with the VAPOR-LOGIC₃ program. Identify the VAPOR-LOGIC₃ program code on the wiring diagram or on the outside of the control cabinet door. Refer to the VAPOR-LOGIC₃ manual to decipher the code using the nomenclature description on Pages 8 and 9.

More on next page ...

Start-up checklist (cont.).

- ❑ Confirm that all wiring is correct per the wiring diagram.
 - ❑ Confirm that proper grounding and an approved earth ground are provided.
 - ❑ Confirm that the J17, J18 and J19 shunt connectors on the VAPOR-LOGIC₃ board are in their correct position per the wiring diagram. See Page 3 for the physical locations.
 - ❑ Confirm that the keypad/display is mounted on the outside of the control cabinet with modular cable routed away from high voltage circuits and connected to the J2 female connector on the control board.
 - ❑ Turn water supply on and confirm that the drain valve (if available) is closed.
 - ❑ Turn power on and confirm that the display shows the “Main Menu” screen with an operational clock.
 - ❑ Enter the “Control Modes” screen and make sure the system is in auto mode.
 - ❑ When the keypad/display shows “Filling” as part of the idle screen information, confirm that the tank is filling with water.
 - ❑ Confirm that the airflow switch is closed.
 - ❑ Confirm that the high limit humidistat input is closed or that the variable air volume (VAV) control system high limit transmitter is connected.
 - ❑ With sufficient water in the tank, the air flow switch closed, the high limit humidistat closed, the safety interlock circuit closed, and a call for humidity, verify that the heat outputs are activated.
-  **IMPORTANT: Confirm that the tank has sufficient water.** If the tank does not contain water and the heat outputs are activated, or the burners are fired by the VAPOR-LOGIC₃ control system, a serious failure will result. If this happens, immediately remove power from the system and verify that all wiring is done per the wiring instructions in this manual and the unit wiring diagram.
- ❑ During normal operation, the keypad/display will show humidifier operating status. See Pages 27 through 36 for descriptions of keypad/display menu items. To change any of the operating parameters, please refer to the above pages.
 - ❑ If you experience difficulties, have the above information available with the model and serial numbers of the humidifier and the VAPOR-LOGIC₃ program code and call DRI-STEEM for help.

Keypad/display overview.

Components of the keypad/display

The VAPOR-LOGIC₃ keypad/display consists of (see Figure 26-1 below):

- A 128 x 64-pixel backlit LCD display
- A power light
- An alarm light
- Eight keys:
 - Four arrow keys
 - An Enter key
 - Three soft keys

A soft key's function is determined by the screen currently displayed.

The arrow keys are used to adjust the values of the different parameters of the humidifier.

The Enter key is used to make selections on various screens.

The power light is illuminated whenever power is applied to the keypad/display.

The alarm light is activated any time a fault condition is detected.

The menu system

The VAPOR-LOGIC₃ keypad/display software organizes the control of the humidification system under six top-level screens:

- Status
- Control Modes
- Alarms
- Set Up
- Diagnostics
- Reports

Each one of these screens is used to view or modify a different characteristic of the humidifier. To access any of these screens, activate the Main Menu of the keypad by depressing the "Main" soft key whenever it is visible. This will immediately take you to the Main Menu selection screen, allowing you to choose where you would like to go next using the up and down arrow keys followed by the Enter key. The menu structure is diagrammed on the opposite page, with a brief description of the submenus on the pages following.

Figure 26-1: VAPOR-LOGIC₃ keypad/display



VAPOR-LOGIC^{®3} menu structure.

Main Menu

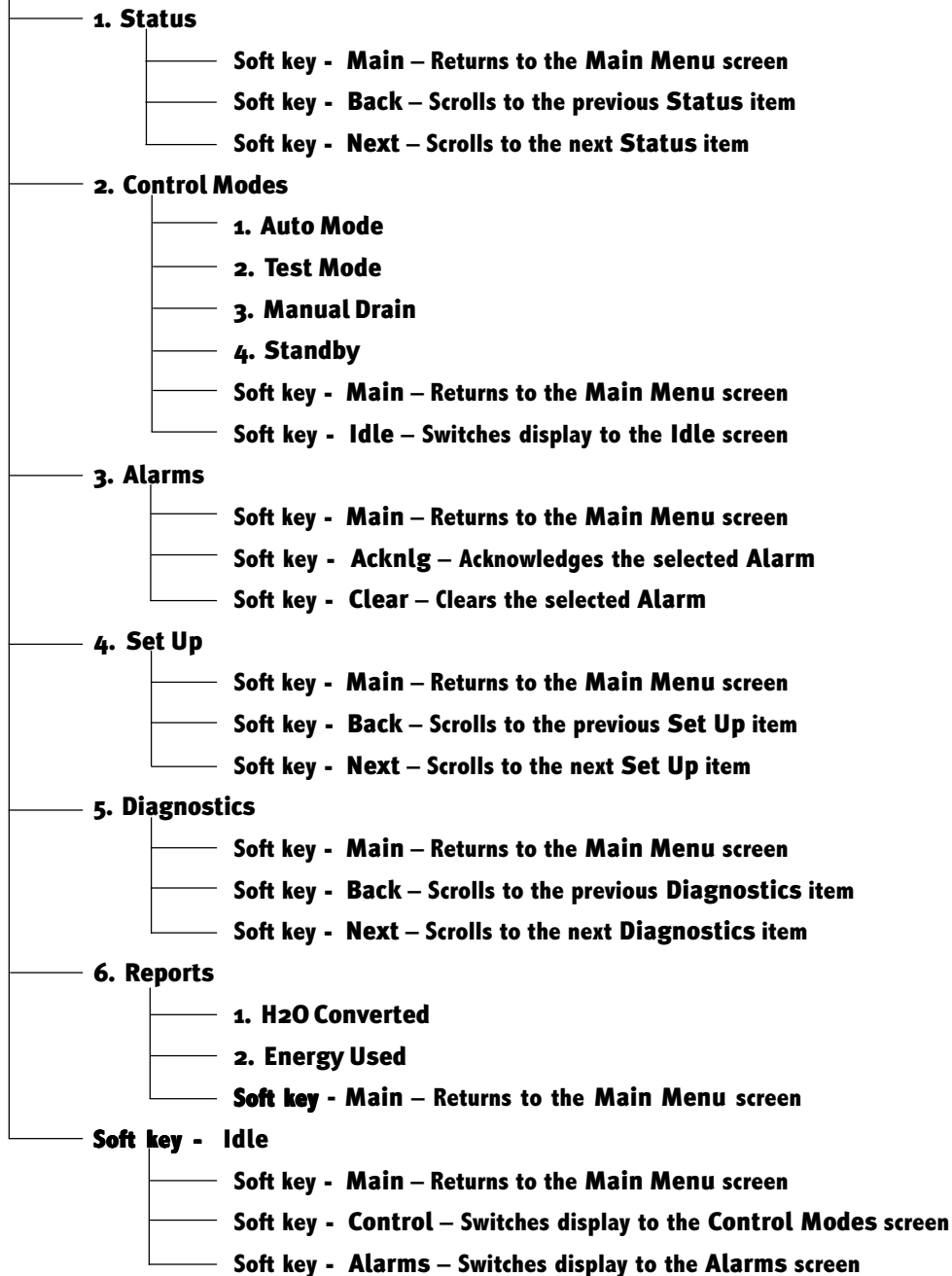

Operation

“Set Up” menu information.

“Set Up” menu readout description	“Set Up” menu description	Range	Default
RH Set point	Relative humidity set point	20-80% RH	35% RH Offset
RH offset calibration	±20% RH	0%	
Dewpoint Set point	Dew point set point	-7-27°C	10°C Dewpoint
Offset	Dew point offset calibration	±20°C	0°C
PID Band	PID loop modulation band	1-20% RH	10%
Kp	Proportional gain factor	1-1000	80
Ki	Integral gain factor	0-1000	40
Kd	Derivative gain factor	0-1000	0
Duct High Lim RH	Duct high limit RH set point	50-95% RH	80% Duct RH Offset
Duct RH offset calibration	±20% RH	0%	
Temp Comp Offset	Temp comp sensor calibration	±20°C	0°C
ADS Mode	ADS operating mode	Use Use + Interval Interval	Use
Kg of H2O until ADS	Kg of water that must be boiled for ADS to start	3-14,863 kg	System dependent
ADS Day	Day to start ADS sequence	Sunday - Saturday	1
Today	Current day of the week	Sunday - Saturday	1
ADS Hour	Hour to start ADS sequence	0-23 (midnight–11:00 p.m.)	0
ADS Interval	Number of days between ADS cycles	0-180 days	7 days
ADS Duration	Autodrain sequence duration	0-120 minutes	8 minutes
AFS Duration	Auto flush sequence duration	0-15 minutes	8 minutes
Service Setpoint	Service interval set point	100-1,486,300 kg	System dependent
Skim Duration	Skim time duration	0-120 seconds	3 seconds
Heater Cycle Time (TP-type control)	Cycle time	30-99 seconds	60 seconds
Heater Cycle Time (SSR-type control)	Cycle time	1-30 seconds	2 seconds
SDU Duration	SDU delay duration	1-30 minutes	2 minutes
Aquastat	Aquastat set point	4-82°C	4°C Inactivity Until
EOS	Inactivity time until EOS drain cycle starts	1-168 hours	72 hours
Set Up Password	Password required to enter the “Set Up” screen	0-32767 (0 = password disabled)	0
Configuration String	See program code nomenclature	System dependent	System dependent
Real Time Clock	Clock and date settings	N/A	Current date/time

Keypad/display readouts.

Readout displayed	Description
Filling	The unit is filling with water.
Skimming	The unit has completed a fill cycle and is now skimming.
Draining	The unit is draining.
Flushing	The unit is flushing.
No Duct Air Flow	The air flow proving switch is open.
Interlock Disable	The interlock circuit is open.
VAV Output Limit	The unit is approaching or has reached the duct RH high limit set point.
Preheating Tank	The unit has received a call for humidity and is preheating the tank.
Freeze Protection	The tank temperature has fallen below the aquastat set point and the unit is being heated.
End of Season Drain	The unit is in end of season drain mode.
End of Season	The unit is in end of season.
Low Tank Level	The water level is below the probes on a standard water unit or below the float on a DI/RO water unit.
Temp Comp	The RH set point has been temporarily modified to prevent moisture from forming on the windows. The modified set point is identified with an asterisk.
Duct RH High Limit	The duct high limit RH has been reached.
Service Humidifier	It is time to perform routine service on the humidifier.

Operation

Main menu: 1) Status.

Status

The Status screen is used to view some of the operating parameters of the humidification system. Some of the parameters that may be displayed include:

- RH setpoint
- Room RH
- Dewpoint setpoint
- Measured dewpoint
- Duct setpoint
- Duct RH
- Window temp
- System demand (%)
- System output (pounds/hour or kilograms/hour)
- Tank temp (°C)
- Water until ADS
- Water until service

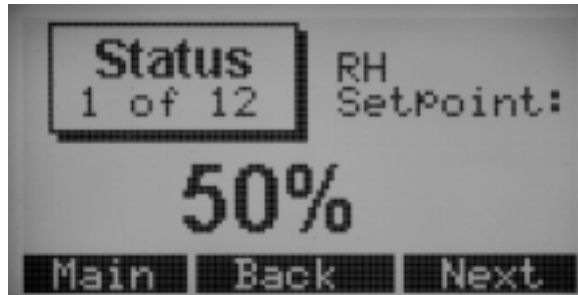

Operation

Main menu: 2) Control Modes.

Control Modes

In the Control Modes screen, the operational mode of the humidifier can be set. You may choose from auto, test, manual drain or standby.

In Auto Mode, the humidifier operates normally. All inputs and outputs are monitored and controlled. If there is a call for humidification, the system will react.

In Test Mode, the controller sequentially cycles through all outputs so that their operation may be confirmed. Once all outputs have been cycled on and off, the controller reverts to the Standby Mode.

In Manual Drain Mode, the automatic drain valve (if so equipped) is opened and the tank is drained. All humidifier operation is suspended and the drain valve is held open until the unit is taken out of Manual Drain Mode.

In Standby Mode, the humidification system is taken off line. All humidity control inputs are displayed but not acted upon.

To select a new mode, use the vertical arrow keys to move the selection pointer on the left hand side of the screen up or down. When the pointer is positioned next to your new selection, press the Enter key. Your new selection will now appear as inverted text.

Note that the current mode of the humidifier is always shown as inverted text on this screen.

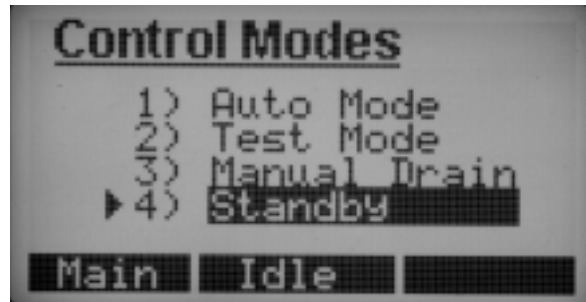

Operation

Main menu: 3) Alarms.

Alarms

The Alarms screen is used to view the alarm log. **Use the vertical arrow keys to scroll through the alarm log.**

The alarm log contains a record of the previous 10 faults that have occurred on the humidifier. The alarms may either be acknowledged or cleared using the soft keys below the display. If an alarm is acknowledged, it will be cleared and left in the log for future reference. If an alarm is cleared, it will be cleared and removed from the log.

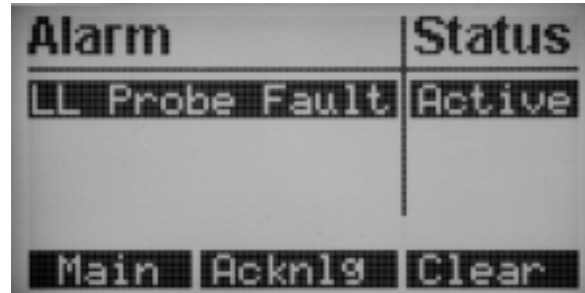

Alarm	Status
LL Probe Fault	Active

Main Acknl9 Clear

Operation

Main menu: 4) Set Up.

Set Up

In the Set Up screen, the operational parameters of the humidifier can be set. Depending on system options, parameters available may include:

- RH setpoint
- RH offset
- Dewpoint setpoint
- Dewpoint offset
- Duct high lim RH
- Duct RH offset
- Temp comp offset
- PID band
- PID gains (Kp, Ki, Kd)
- ADS mode
- Kg of H₂O until ADS
- ADS day
- Today
- ADS hour
- ADS interval
- ADS duration
- AFS duration
- Inactivity until EOS
- Service setpoint
- Water until service
- Heater cycle time

- Skim duration
- SDU duration
- Aquastat
- Configuration string
- Date/Time set
- Set up password

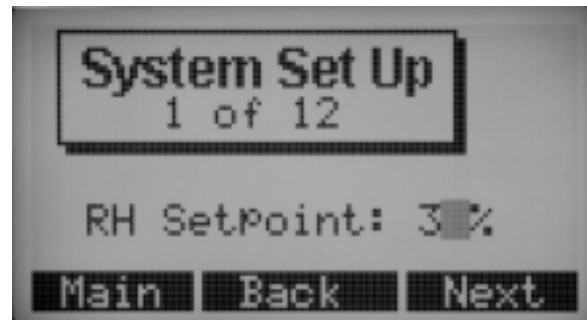

To modify a value, use the Next and Back soft keys to locate the parameter in need of modification. Once the parameter has been located, use the vertical arrow keys (or + and - keys) to change values, and use the left and right arrow keys to move to different place holders. **When you are finished, you must press either the Next or Back soft keys, or the Enter key to save your change.** If you press the Main soft key without first pressing one of these other keys, your modification to that particular parameter will be lost.

Main menu: 5) Diagnostics.

Diagnostics

The Diagnostics screen enables you to troubleshoot some of the hardware input and output points of the VAPOR-LOGIC[®]3 control system. The soft keys Next and Back are used to move through the diagnostic options. Once you have found the item you would like to troubleshoot, view the reading and compare it with what the value should be.

For example, if you were going to troubleshoot the RH signal input, you would select RH Signal on the Diagnostics screen. The display would then tell you what the current input signal is in mA. It would also tell you what this voltage translates to in terms of relative humidity. You can then verify that the input is working correctly.

Depending on system options and type, diagnostics available may include:

- RH input
- Demand input
- Dewpoint input
- Duct HL input
- Temp comp input
- High probe voltage
- Mid probe voltage
- Low probe voltage
- DI float
- Tank temp input
- Air flow switch
- Safety interlock
- Blower No. 1 RPM
- Blower No. 2 RPM
- Burner No. 1 gas valve
- Burner No. 2 gas valve
- Combustion air switch
- Power vent switch
- Flue differential pressure switch

Operation

Main menu: 6) Reports.

Reports

The Reports screen is useful for viewing historical information about your humidifier. In this section, you are able to view the amount of water that has been used by your humidifier and the amount of energy it has consumed.

Operation

Main menu: Idle screen.

Idle Screen

The Idle screen allows you to monitor the humidifier's basic operation. Depending on system options, you may view system set point, the actual space condition and the system demand.

The top line of the display informs you of the current mode of the humidifier.

The second line is a system status line. This line will continuously scroll through any system status items that are currently present. This may include (depending on your system's options) Filling, Skimming, No Duct Air Flow, High Limit Disable, etc. The soft keys in this mode provide quick, direct access to the Control Modes screen, the Alarms screen or back to the Main Menu screen.



Control modes.

On-off control

On-off control is the simplest control scheme, and does exactly what its name implies: the output device turns fully on, then fully off.

The on-off humidistat differential is designed into the control action between the on and off switching points. The differential is established at a range sufficient to prevent output short-cycling. In other words, the humidity level will have to fall a little below set point before the humidistat will close and energize the humidifier. Once the humidifier is energized, the humidistat will stay closed until the humidity is a little above set point. This creates an operating range that prevents the humidifier from running for very short periods of time.

This type of operation is applicable to all DRI-STEEM humidification systems controlled by VAPOR-LOGIC₃. In applications where there are multiple contactor outputs, such as a VAPORSTREAM®, the contactors for the different heat stages are pulled in one at a time with a two second interval between them. In applications with a variable output stage, such as an STS® or GTS®, the outputs are ramped up until they reach 100%.

Demand signal control

With demand signal control, the VAPOR-LOGIC₃ controller provides the output level that a master control signal calls for. This signal can either be generated by a humidistat or by a building energy management system. The signal that is sent to the VAPOR-LOGIC₃ board is a modulating signal (typically 4-20 mA or 0-10 VDC). The board responds to this signal by producing a directly proportional output. In other words, with a 4-20 mA signal, a command of 4 mA would produce no output. A command of 12 mA would have the humidifier running at 50% capacity, and a command of 20 mA would have the humidifier running at 100% capacity. With a humidistat provided by DRI-STEEM providing this signal, the humidity set point is set at the humidistat. The keypad/display is then used for maintaining and troubleshooting the humidification system, with humidifier control stemming from the humidistat itself. With an energy management system (EMS) providing the signal, the humidity set point is established somewhere on the EMS and the humidifier responds to the EMS commands.

Transmitter control

With transmitter control, the VAPOR-LOGIC₃ board receives a linear signal that corresponds to the actual humidity level being measured. (With a DRI-STEEM-provided transmitter, the signal is 4-20 mA, which corresponds with 0-100% RH.) The VAPOR-LOGIC₃ controller then uses this humidity measurement, along with a user defined desired humidity set point, and calculates a demand level. This demand level is the level at which the humidifier will run.

Modulation types: TP modulation.

TP modulation

The standard form of modulation with an electric humidifier is TP (time-proportioning) modulation. With this type of modulation, the outputs are cycled on and off at a certain rate to approximate humidifier demand.

For example, if a VAPORSTREAM® humidifier has four heat output stages (four contactors) and a demand of 55%, two of the contactors will be energized all of the time, one contactor will be cycling on and off at a certain rate, and one contactor will be off all of the time. The rate at which the third contactor cycles is determined by the demand and the TP cycle time. Continuing with our example, if we have a TP cycle time of 60 seconds and a demand of 55%, the third contactor will be cycling at a rate of 12 seconds on and 48 seconds off.

To calculate the above example, imagine that each contactor represents 25% of the output of the humidifier. With a 55% system demand, we need two full contactors plus 5/25 of a third contactor. Therefore, two contactors will be full on and a third contactor will be on for 5/25 of 60 seconds, or 12 seconds.

To minimize wear on the contactors that are cycling, VAPOR-LOGIC₃ keeps track of the number of cycles on all contactors and it will rotate the TP cycling contactor through the stages to ensure that they all get equal wear. In addition, no contactor will ever have a cycle time of less than two seconds or greater than two seconds less than the TP cycle time. In other words, if a contactor needs to be on for less than two seconds because of the way the math turns out, the contactor will be energized for the minimum two second period. Also, if a contactor needs to be de-energized for less than 2 seconds, it will stay on. This prevents quick cycling of the contactors and extends their life. On a TP system with contactors, the TP cycle time is user-adjustable and can be set from 30 seconds to 99 seconds via the VAPOR-LOGIC₃ keypad/display.

Modulation types: SSR modulation.

There are two basic types of SSR modulation: SSR modulation with contactors, and 100% SSR modulation.

SSR modulation with contactors

With SSR modulation with contactors, the operation of the unit is the same as it is with TP Modulation. In this scenario, one of the cycling contactors is replaced with an SSR. The SSR is now the device that carries out all of the cycling duties. The contactors will always be either on or off. Any TP cycling that is needed will be handled by the SSR stage.

This provides two distinct advantages over standard TP modulation. First, an SSR can turn on and off much faster than a contactor can. Therefore, as the unit modulates around a demand signal, tighter control is achieved because the cycle time on an SSR system is factory-set at one second. This means that every second, the controller can adjust the on and off times on the SSR to very closely track the desired demand.

The second major advantage over standard TP modulation is reliability. With a solid state device like an SSR, component wear and tear is almost nonexistent when compared with an electromechanical device such as a contactor. Therefore, with the SSR doing all of the heavy cycling work, the life expectancy of the contactors is extended.

100% SSR modulation

The ultimate in electric humidifier modulation is 100% SSR Modulation. With this type of control, all heat stages are controlled by SSRs. This allows the output of the humidifier to track the actual demand very closely because all heat stages can now cycle on and off at the rapid SSR cycle rate.

With 100% SSR modulation, a contactor is still provided in series, with the SSR device as an additional safety feature. This contactor is energized any time there is demand on the humidifier, and remains energized until the demand is satisfied. In this way, if there is a failure in the SSR device, the contactor is there as a backup to shut the humidifier down.

Modulation types: valves and burners.

STS® and LTS® valve modulation

With a valve system, the modulation is very simple. The demand signal simply determines how far the valve is going to open. In other words, if the system demand is 25%, the valve will be open 25%.

GTS® burner modulation

The burner assembly used on a GTS consists of a variable speed blower, a constant air/gas ratio modulating gas valve, and a burner. Depending upon the burner size, the type of gas, and the venting option, burner output can modulate from a minimum of 25-90% of its rated capacity up to 100% of its rated capacity. To accomplish this turndown, the VAPOR-LOGIC[®]₃ controller monitors the blower tachometer feedback and uses it, in conjunction with the system demand, to control the blower speed. As the blower speed varies, the gas valve automatically adjusts the amount of gas introduced into the burner to maintain a constant air/gas ratio. This variable combination of gas and air results in clean combustion over the entire range of the burner capacity.

When individual burner demand falls below its minimum rating (25-90% depending on options), burner operation changes from modulated to Time Proportioned (TP). TP simply means that the burner output is kept constant, but is cycled on and off. The burner cycle time is two minutes, and the on time of the burner is proportional to the system demand. The breakpoint between burner modulation and burner time proportioning depends upon system options.

To ignite the burner, the blower is run at a speed optimized for ignition to provide the smoothest, quietest, most reliable ignitions. If the tank is cold, the unit will run at 100% capacity to preheat the tank. Once the tank temperature rises above 88°C, the burner will resume normal operation. In a two burner system, one burner will always be running, while the other burner may or may not be running depending on system demand. Once both burners are off, they will switch roles upon re-ignition to maintain even wear on combustion system components.

Control functions: adjusting set point.

Adjust set point through Set Up menu

Set point adjustments are accomplished through the Set Up menu, which is under the Main Menu (refer to the menu structure diagram on Page 27).

Once you have accessed the Set Up menu, you will be able to adjust a number of parameters including the set point of the unit. To adjust the humidity set point, your unit must be configured for a humidity transmitter. You may enter a desired humidity set point anywhere in the range of 20% to 80%. Your set point modifications will take effect as soon as you press the Enter key or move to another parameter using the Next or Back soft keys, or exit the set up menu using the Main soft key.

Depending on your options, you may also be able to adjust the high limit humidity set point and the dew point set point. The high limit set point has a valid range of 50% to 95%. The dew point set point has a valid range of -7°C to 27°C. If your unit is equipped with the dew point control option, you will not have a desired humidity set point option.

Control functions: PID tuning.

Tune your system with PID loop

When your unit is equipped with a humidity or dew point transmitter (when you are able to adjust the set point through the keypad/display) control is accomplished through a PID control loop. PID stands for Proportional, Integral and Derivative.

With a PID loop, you are able to “tune” your system for maximum performance using the proportional (Kp), integral (Ki) and derivative (Kd) gain terms. These gain factors work in the following way: The overall demand in a PID system is made up of three distinct parts that are added together. There is the proportional piece, the integral piece and the derivative piece. Each one of these parts is calculated and then multiplied by a gain factor. These gain factors are the setup variables that you have access to. By making a gain factor larger, you increase its component’s overall influence on the system demand equation. Once the multiplication has taken place, all three terms are added together to determine the overall demand percentage. One other term that is user-controlled in the PID equation is the proportional band.

The proportional term

The proportional band is the band (in % RH, or °C for dew point control) in which the humidifier will modulate.

For example, if starting with a set point of 35% and a proportional band of 10%, the humidifier operation will be as follows: On initial start-up, assume an actual humidity level of 15%. The proportional band is 10% so the humidifier will modulate when the actual humidity is in the range 25-45%. If the actual humidity is lower than 25%, the humidifier will be full on. If the actual humidity is above 45%, the humidifier will be full off. In the example, starting at an actual humidity level of 15%, the humidifier will be full on. As the actual humidity level climbs into the range of the proportional band (25-45%), the humidifier will begin to modulate down. Once the set point of 35% is reached, the humidifier will be full off.

Looking at this scheme a little closer, a problem can be found. In almost all applications there will be some constant load on the humidifier just as there is a constant load on the heating equipment. With this control scheme, the actual humidity must be less than the set point for the humidifier to be on. What ends up happening is the humidifier finds a “happy medium” where the actual humidity is something less than the set point, which allows the humidifier to continue to run. This difference between the set point and the actual running humidity level is called the “droop.” This droop can be corrected using the next term, the integral gain.

Control functions: PID tuning (cont.).

The integral term

The integral gain affects how fast the humidifier will react to a droop condition. The higher the number, the faster the reaction. (An integral term of zero disables this variable and allows the unit to run on the proportional band only.) The way this term works is as follows: When the actual humidity is in the proportional band, the humidifier demand is somewhere between 0 and 100%. Every half second the demand is updated. With an integral gain term greater than zero and an actual humidity below set point, each time the demand is updated it is increased slightly. If the actual humidity is above set point, the demand will be decreased slightly. The amount it is increased or decreased is dependent on the difference between the actual humidity and set point. (The closer you are to the set point, the smaller the addition or subtraction.)

When looking at this control scheme, something interesting is found. The total demand signal for the humidifier is the sum of the proportional part, the integral part and the derivative part. As the actual humidity approaches the set point, the integral portion makes up the majority of the demand and the proportional part makes up very little. Once the set point is achieved and the unit stabilizes, the entire demand is made up of the integral part because the proportional part is zero. If the actual humidity goes over the set point, the integral term will start to decrease. In addition, the proportional term will go negative and actually start to subtract from the total system demand. These two items work in conjunction with each other to bring the humidifier back to set point.

The derivative term

A derivative term's basic function in a PID loop is to anticipate where the demand is going and to help it get there. Its basic operation is as follows: As the humidifier is running, the PID loop is generating an error term. (The error term is the mathematical difference between the RH set point and the actual measured RH.) If the actual measured RH is below set

point and is rising, the derivative term will subtract from the demand in anticipation of the approaching set point. If the actual measured RH is below set point and is falling, the derivative term will add to the demand in anticipation of the need to get the demand up faster and start climbing toward set point. The same is true for situations above the set point. If the actual measured RH is above set point and is rising, the derivative term will subtract from the total demand in anticipation of needing to reduce demand and get closer to set point. If the actual measured RH is above set point and falling, the derivative term will add to the overall demand in anticipation of the approaching set point. In the majority of control situations, the derivative term is not needed and is simply set to zero. The proportional term and integral term will provide very tight, accurate control without the addition of the derivative term.

PID setup tips

A large proportional band (10 to 20%) will yield tighter and more stable control with longer response times. A small proportional band will produce quicker response times but control may become unstable. As a rule of thumb, start with a band of 10%. If the unit does not "hunt" and a quicker response is needed, the band can be lowered. If the unit hunts or the fast response is not needed, increase the band. This will result in more system stability. (To increase or decrease the effect of the proportional band on system performance, the proportional gain factor may be adjusted. However, for the majority of systems, the factory default setting of 80 is sufficient.) A moderate integral gain term (30 to 50) will also yield tighter and more stable control with a longer response time. A large integral gain will quicken the response but may cause the system to become unstable. As a rule of thumb, start with an integral term of 40. If the unit does not hunt and quicker response is needed, raise the integral gain. If the unit hunts or does not need the fast response, decrease the integral gain.

Operation

VAV, temp comp, dew point control.

VAV control

With VAV control, the system is equipped with a duct high limit transmitter. This transmitter sends a signal back to the VAPOR-LOGIC₃ controller. The controller then compares the measured duct RH with the high limit set point (Duct High Lim RH) that is entered through the keypad/display in the Set Up screen. As the measured duct RH approaches the high limit set point, the system output is proportionally throttled back. (This scaling of the output starts once the measured RH is within 6% of the high limit set point.) Once the measured duct RH drops, full system output is automatically restored.

Temperature compensation control

With temperature compensation (temp comp) control, the system is equipped with a window temperature transmitter. This transmitter sends a signal back to the VAPOR-LOGIC₃ controller. As the window glass temperature decreases and approaches the dew point of the room, the RH set point is automatically decreased to prevent moisture or ice from forming on the window. Once the window temperature rises, the original RH set point is restored. This option is only available when the system is equipped with an RH transmitter. It is not available when a remote humidistat or energy management system is used to control the humidifier.

Dew point control

Dew point control functions in exactly the same way as RH control except the dew point is being measured instead of the RH. The dew point transmitter sends a signal back to the VAPOR-LOGIC₃ controller. The user is able to modify the dew point set point and PID parameters through the keypad/display just as they could with an RH transmitter.

Aquastat, heat-up, SDU, offsets, metric.

Aquastat operation

The aquastat set point is the minimum tank temperature the VAPOR-LOGIC₃ controller should maintain. It is adjusted through the Set Up screen. This feature is typically used to keep the tank from freezing in a cold environment. However, it can also be used to hold a higher minimum temperature if a quick response to a demand signal is needed. For example, if the aquastat is set at 82°C, when a call for humidity occurs, the tank will only need to warm up 18°C to reach the boiling point and start producing steam. However, if the aquastat is at its minimum setting of 4°C and the tank is in an average-temperature occupied room, the tank will be sitting at about 21°C. Now, when a call for humidity occurs, the tank will need to warm up 79°C to reach the boiling point and begin producing steam. This feature is standard on all

DRI-STEEM humidifiers with VAPOR-LOGIC₃ control except ULTRA-FOG[®] and Steam Injection humidifiers.

Tank heat-up feature

The tank heat-up feature uses the tank temperature sensor to quickly heat a tank in response to a demand signal. Its operation is as follows: If the tank is cold (34°C) and a small demand signal is delivered, the VAPOR-LOGIC₃ controller will override the demand signal and run the humidifier at 100% demand until the tank temperature is 88°C. At this point, control will be returned to the original demand signal and the humidifier will begin normal operation. This allows the system to respond quickly to even the smallest demand. This feature is standard on all DRI-STEEM humidifiers with VAPOR-LOGIC₃ control except ULTRA-FOG and Steam Injection humidifiers.

SDU timer

If your humidifier is equipped with a Space Distribution Unit (SDU) or an Area-Type fan, you have the option of controlling how long the fan will run after a call for humidity has ended. This delay (SDU Duration) is adjustable in one-minute intervals through the Set Up screen.

Sensor offsets

All external transmitters shipped with VAPOR-LOGIC₃ can be field calibrated using the keypad/display through the Set Up screen. For example, if the system is equipped with an RH transmitter, there will be an RH offset setting. The factory default for all transmitter settings is zero. However, if an adjustment is necessary, the keypad can be used to adjust the transmitter reading up or down through this setting. The sensors that have this adjustment capability are the humidity, VAV high limit, temp comp and dew point transmitters.

Metric conversion

VAPOR-LOGIC₃ is capable of displaying all information in metric as well as English units. To change the current setting, modify the “type of units” in the configuration string under the set up menu.

Operation

Water level control: conductivity probe.

Probe system

Standard water systems use a conductivity probe to control water levels for optimum operating efficiency. The three-probe system is monitored by the VAPOR-LOGIC₃ board, which performs all the necessary logic and timing functions to provide total water level control and safety shutdown.

VAPOR-LOGIC₃ automatically maintains the water level between the upper two probes A and B (see Figures 46-1 and 46-2 below). When the water level falls below probe B, the fill valve is opened until the water level reaches the upper probe A. Water must remain in contact with the probe surface for a minimum of two seconds for VAPOR-LOGIC₃ to determine that the water is at the probe's level, ensuring that turbulence does not cause an incorrect level reading.

Each time the fill valve is energized, the probe system is tested by the VAPOR-LOGIC₃ system. If the signal from the probe assembly is beginning to deteriorate, the message "Replace probes" will appear. Once the probe system has reached its maximum usable life, the humidifier will shut down and the message "Probe fault" will appear.

An adjustable skim time allows for an extended skim period (0-120 seconds) to reduce surface mineral accumulation. When skimming, the fill valve remains energized for the designated delay time after the water level reaches the upper probe A.

Probe C provides low water protection for the heating elements. If the water level falls below probe C, the heaters are de-energized.

Figure 46-1: Conductivity probe system for GTS®, VLC®, VAPORMIST® and CRUV®

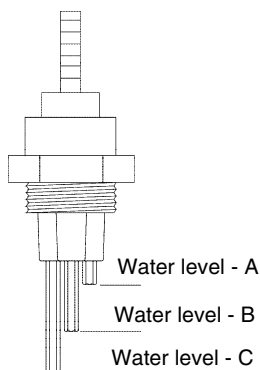

OM-632

Figure 46-2: Conductivity probe system for STS® and LTS®

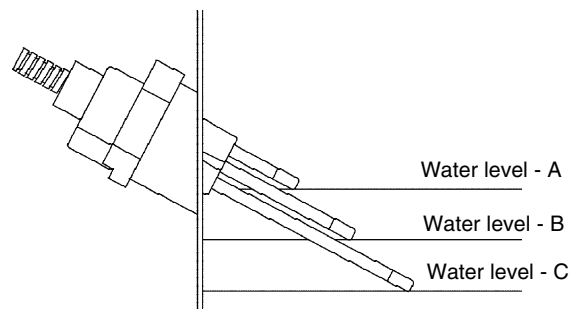

OM-270

Water level control: float valve.

Float valve system

DI/RO water systems (except for ULTRA-FOG[®]) use a float valve system to control water levels for optimum operating efficiency. DI/RO systems are used where water/steam purity is important, where demineralized water is needed to improve performance or lessen maintenance requirements, or where a potable water source has minimal or no conductivity, thus requiring a float rather than a probe to sense water levels.

The float valve system consists of a fill float and a low-water cutoff float.

The fill float regulates how much water is added to the tank via a float, float arm and mechanical valve. The valve is adjusted to within 6 mm of the overflow (skimmer) port allowing heated and therefore expanded water at start-up to fill the external P-trap.

The low-water cutoff float has an electrical switch that closes when a ready-water condition is reached. A low voltage AC current runs from the VAPOR-LOGIC₃[®] controller to the switch allowing the controller to sense when the voltage drops as the switch closes to ground at a ready-water condition.

Figure 47-1: Float valve system used with DI/RO systems

Stripe mark indicates proper float ball placement on stem. Switch is normally open when float ball is at its lowest point on stem.

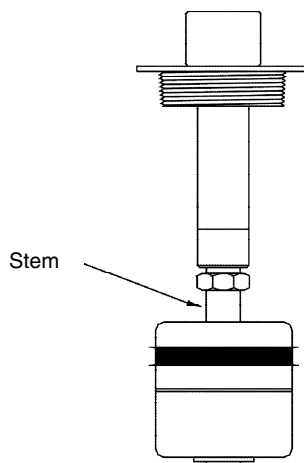

OM-3009

Drain and flush, skim.

Drain and flush options

VAPOR-LOGIC[®]₃ is preprogrammed to enter an automatic drain, flush and refill cycle to help keep mineral concentrations in the tank to a minimum. The method by which this is accomplished is selected by the user through the keypad/display in the Set Up screen. The three options available are:

1. Flush after usage
2. Flush at a certain time after usage, and
3. Flush at a certain time

Please note that these options are only available with a standard water system having an automatic drain valve. If the humidifier is configured for DI/RO water, or if the unit has a manual drain valve, these drain and flush options are not available.

In the flush after usage mode, the humidifier will enter the drain and flush sequence after a user-selected amount of water has been converted to steam. In other words, if the user set the drain and flush interval to 4,500 kg, the unit will enter the drain and flush sequence the moment 4,500 kg of water have been boiled.

In the flush at a certain time after usage mode, the humidifier will enter the drain and flush sequence at a specific time after a user-selected amount of water has been converted to steam. In other words, if the user sets the drain and flush interval to 4,500 kg and the ADS Hour to 2, the unit will enter the drain and flush sequence at 2:00 am after 4,500 kg of water have been boiled. This allows the user to keep the humidifier on line until a convenient time for the drain and flush sequence.

In the flush at a certain time mode, the humidifier will enter the drain and flush sequence at a specific time, ignoring the amount of water that has been converted to steam. In other words, if the user sets the ADS Hour to 2, and the ADS Interval to 7 days, the unit will enter the drain and flush sequence every 7 days at 2:00 am.

When VAPOR-LOGIC₃ initiates the drain and flush sequence, all activated heat sources are deactivated. The drain valve is then opened to allow the tank to drain. The drain valve remains open during the flush sequence for drainage while the fill valve is open. At the completion of the flush cycle, the drain valve closes allowing the fill valve to refill the tank. For multiple tank systems, only one tank at a time enters the drain and flush sequence in order to keep as much capacity available as possible.

Skim timer

With a standard water configuration, the VAPOR-LOGIC₃ controller comes equipped with a skim timer. This timer is activated at the end of each fill cycle. The timer keeps the fill valve open for a user-determined amount of time after the tank has filled to skim minerals off the water surface. The skim time is adjusted through the Set Up screen on the keypad/display.

Operation

Service interval, EOS, date set.

Service interval

The VAPOR-LOGIC³ controller keeps track of how much water has been converted to steam. After a user-defined number of kilograms have been boiled, a service humidifier message will appear on the keypad/display. However, the humidifier will continue to operate after the message appears. The message is simply to notify the user that the service interval has been reached. This service interval is adjustable through the Set Up screen on the keypad/display.

End of season drain

If there is no call for humidity for a preset time period, the humidifier will be placed in End of Season (EOS). When the unit enters End Of Season, the humidifier is placed in Standby Mode. The drain valve is held open for one hour to allow the tank to drain and then it is closed. If the humidifier receives a call for humidity after the end-of-season drain, it automatically leaves the Standby Mode and returns to the Auto Mode. The tank is refilled and the humidifier resumes normal operation. The amount of inactivity time that is needed before the humidifier enters End Of Season is adjustable through the Set Up screen on the keypad/display (Inactivity Until EOS). This option is only available on units that are equipped with automatic drain and fill valves.

Setting date and time

The VAPOR-LOGIC³ controller contains a real-time clock that is used for several features including the drain and flush sequence and the logging of alarms. If it becomes necessary to reset the date or time, they are accessible through the Set Up screen on the keypad/display.

Operation

Safety features.

Fill timer

The VAPOR-LOGIC[®]₃ controller keeps track of approximately how much water, in the form of steam, has left the tank. If this total amount exceeds a preset limit without the fill valve being energized, a low water condition is assumed and the humidifier is shut down. Each time the fill valve is energized, the total is reset to zero. Note that this system is not used on a DI/RO humidifier because the fill valve is not an electric-solenoid type. On a DI/RO tank, a mechanical fill valve maintains the proper water level. This fill valve operates independently of the VAPOR-LOGIC₃ controller. Therefore, on a DI/RO system, there is no way to reset the steam total to zero as the tank fills.

Over-temp fault

The tank temperature is constantly monitored by the VAPOR-LOGIC₃ controller. If the temperature ever rises above a preset limit, the humidifier is shut down and a thermal trip fault is given on the Alarms screen of the keypad/display. This fault must be cleared or acknowledged on the Alarms screen by the user before humidifier operation will resume.

Fault messages, diagnostics.

Alarms screen

The Alarms screen on the keypad/display logs the last ten alarms that have occurred on the humidifier. To scroll through the alarms, use the up and down arrow keys. You can acknowledge or clear any one of the alarms using the appropriate soft keys. If an alarm has occurred that you would like to get more information about, highlight that alarm using the arrow keys and then press the Enter key. A screen will appear that gives you the time and date the alarm occurred as well as a more detailed explanation of what the alarm means.

Sensor faults

The following is a list of sensor faults that can occur. Please note that this is a complete list of faults. Your system may not have all of these options. The text in parentheses is what will actually appear in the alarm log.

- **Humidity transmitter fault (RH Trans Fault)**
The humidity sensor is incorrectly wired or bad.
- **Dew point transmitter fault (DP Trans Fault)**
The dew point sensor is incorrectly wired or bad.
- **VAV humidity transmitter fault (VAV Tran Fault)**
The duct humidity sensor is incorrectly wired or bad.
- **Temp comp transmitter fault (Temp Trans Flt)**
The temperature compensation sensor is incorrectly wired or bad.

Fill and drain faults

The following is a list of fill and drain faults that can occur. Please note that this is a complete list of faults. Your system may not have all of these options. The text in parentheses is what will actually appear in the alarm log.

- **Fill fault (Fill Fault)**
The fill valve has been energized for more than 40 minutes without the water reaching the top probe.
- **Drain fault (Drain Fault)**
The drain valve has been energized for more than 20 minutes without the water falling off the bottom probe.
- **Low water timer fault (Fill Time Flt)**
The unit has run too long without the fill valve opening.
- **Low-level probe fault (LL Probe Fault)**
The water in the tank has reached the middle or upper probe without reaching the lower probe.
- **Mid-level probe fault (ML Probe Fault)**
The water in the tank has reached the upper probe without reaching the middle probe.
- **Probe assembly fault (Probe Assy Flt)**
The system has detected the deterioration of the probe assembly to a point that replacement is necessary.

Fault messages, diagnostics (cont.).

Humidifier faults

The following is a list of humidifier faults that can occur. Please note that this is a complete list of faults. Your system may not have all of these options. The text in parentheses is what will actually appear in the alarm log.

- **Temperature sensor fault (Tank Temp Flt)**
The temperature sensor on the humidifier tank is incorrectly wired or bad.
- **Thermal trip fault (Thermal Trip)**
The tank temperature has exceeded 118°C.
- **SDU fault (SDU Fault)**
The SDU blower pressure switch failed to close when the SDU was started.
- **EEPROM fault (EEPROM Fault)**
The controller has detected a check sum fault in the EEPROM memory.
- **Flue fault (Flue Fault)**
The air damper limit and/or the power vent pressure switch failed to close.
- **Burner No. fault (Burner No. Fault)**
The burner failed to light after three ignition attempts.

The ignition module failed to energize the gas valve.

- **Blower No. fault (Blower No. Fault)**
The blower was unable to reach the desired speed.
- **GTS[®] only: Slave No. fault (Slave No. Fault)**
One of the humidifiers in a multiple tank system is not responding to communication requests.
- **Boil time fault (Boil Time Flt)**
The water in the tank failed to boil within the maximum boil time.

Sensor meter feature

The Diagnostics screen on the keypad/display contains the sensor meter feature. This feature allows the user to read the state of all of the current inputs to the VAPOR-LOGIC₃[®] controller.

- **Ignitor No. fault (Ignitor No. Fault)**

Reports, multiple tank systems.

To scroll through the screens, use the Next and Back soft keys to select the input you wish to check. When you are done, press the Main soft key to return to the Main Menu screen.

Energy usage report

The energy usage report gives an approximate total of how much energy has been consumed by the humidifier since the last service interval. Depending on the system type, this number may be in kWh, MBTU, therms, etc.

Water usage report

The water usage report gives an approximate total of how many kilograms of water have been converted to steam since the last service interval.

Multiple tank systems

The VAPOR-LOGIC₃ controller has the ability to be connected via a LonTalk® network to control up to six tank humidification systems. These multiple tank systems operate in exactly the same way as single tank systems. The multiple tanks work together to generate the desired level of humidity. The humidifiers are brought on line sequentially, which means that one humidifier must be running at full capacity before the next one is brought on line. However, the VAPOR-LOGIC₃ controller monitors the demand signal and will begin to preheat additional tanks as the demand signal rises so that there is a seamless transition in output when additional tanks are brought on line.

Troubleshooting 1, 2, 3.

1.

Review troubleshooting index

If you find that you are having a control-related problem, first check the problem list on the next page. If you are having a tank- or dispersion-related problem, you may also need to refer to those specific product manuals.

2.

Review possible causes and recommended actions

The troubleshooting section presents possible causes and recommended actions for typical problems.

3.

Call us if you're still having problems

If the troubleshooting guide does not help you solve your problem, call us with the following information available:

- 1. Product name, program code, and order number**
You'll find this information on the wiring diagram and on the outside of the control cabinet door.
- 2. Problem definition**
(Water leaking, low humidity, high humidity, etc.)
- 3. Time problem began**
(Always, after remodel, after a change in weather)
- 4. System changes**
(Pressure, new boiler, new service, new controller, relocation, change in maintenance)

Humidifier model number _____

Humidifier serial number _____

VAPOR-LOGIC₃ program code _____

Index to troubleshooting guide.

The following is an index to possible control-related problems described on the following pages. To find solutions, refer to either the problem number or the page number shown.

No. Description

- 1. Green power indicator light is off Page 56
- 2. No remote fault indication Page 56
- 3. No readable information on keypad/display ... Page 56

Faults

- 4. Humidity transmitter fault Page 56
- 5. Dew point transmitter fault Page 57
- 6. Humidistat fault Page 57
- 7. VAV humidity transmitter fault Page 58
- 8. Temp comp transmitter fault Page 58
- 9. Fill fault Page 58-59
- 10. Drain fault Page 59-60
- 11. Low water timer fault Page 60
- 12. LL probe fault Page 60-61
- 13. ML probe fault Page 61-62
- 14. Replace probes fault Page 62-63
- 15. Probe assembly fault Page 63
- 16. Temperature sensor fault Page 63
- 17. Thermal trip fault Page 63
- 18. SDU fault Page 63
- 19. EEPROM fault Page 64
- 20. Flue fault Page 64
- 21. Burner No. fault Page 64
- 22. Ignitor No. fault Page 65
- 23. Blower No. fault Page 65
- 24. Slave No. fault Page 65

Operation problems

- 25. Control does not energize Page 65
- 26. Unit does not fill with water Page 66
- 27. Fill valve does not close Page 67-68
- 28. Reduced or no output Page 68
- 29. Fill valve cycles on and off frequently Page 69
- 30. Heater burnout Page 69
- 31. Noisy operation Page 70
- 32. Humidity below desired level Page 70-71
- 33. Humidity above set point Page 72
- 34. Hunting Page 72-73
- 35. Unit does not perform autodrain sequence Page 73
- 36. Tank does not heat up Page 73-74
- 37. Unit does not perform auto-drain sequence Page 74
- 38. Unit does not perform end of season drain Page 75
- 39. Humidifier tank has proper water level
and is always warm Page 75

Troubleshooting guide.

Problem number	Problem	Possible cause	Action
1	Green power indicator light is off.	• No control voltage present	• Check for proper supply voltage.
		• Heater fuses open	• Check heater fuses for voltage present at transformer.
		• Transformer secondary circuit breaker tripped	• Check for wiring shorts; reset breaker.
2	No remote fault indication	• Field wiring not installed	• Provide field wiring to a remote fault indicator from VAPOR-LOGIC ₃ terminal block J22.
		• Field-supplied remote fault indicator lamp is burned out.	• Check if lamp by others is burned out; replace if needed.
		• Remote fault VAPOR-LOGIC ₃ relay is not switching.	• Check relay continuity (VAPOR-LOGIC ₃ terminal J22) for contact closure.
3	No readable information on keypad/display	• No power, or incorrect voltage to VAPOR-LOGIC ₃ board	• Check main power supply.
		• Modular communication cable is disconnected.	• Connect modular cable.
4	Humidity transmitter fault	• Open, shorted, or incorrect wiring of transmitter or humidistat	• Check D.C. supply voltage terminals: 21+, 23-(21 VDC)
		• Signal by others. Incorrect, out of range or miswired.	• If there is no output, 4-20 mA, replace transmitter. Transmitter by others is not compatible. Consult DRI-STEEM.
		• Gound loop	• Isolation board by others.
		• Control signal by others has exceeded the range limits. Correct control signal to 4-20 mA, 0-135 Ohms, or 0-15 VDC.	• Recalibrate if there is a calibration error: Normal Range 4-20 mA = 0-100% RH 12 mA = 50% RH. • Measure for normal 1-5 VDC range on Control RH transmitter or 4-20 mA by others: 22 +, 23-.

More on next page ...

Troubleshooting guide.

Problem number	Problem	Possible cause	Action
5	Dew point transmitter fault	<ul style="list-style-type: none"> • Open, shorted, or incorrect wiring of transmitter or humidistat 	<ul style="list-style-type: none"> • Check D.C. supply voltage terminals: 21+, 23-(21 VDC)
		<ul style="list-style-type: none"> • Signal by others. Incorrect, out of range or miswired. 	<ul style="list-style-type: none"> • If there is no output, 4-20 mA, replace transmitter. Transmitter by others is not compatible. Consult DRI-STEEM.
		<ul style="list-style-type: none"> • Ground loop 	<ul style="list-style-type: none"> • Isolation board by others.
		<ul style="list-style-type: none"> • Control signal by others has exceeded the range limits. Correct control signal to 4-20 mA, 0-135 Ohms, or 0-15 VDC. 	<ul style="list-style-type: none"> • Recalibrate if there is a calibration error: Normal Range 4-20 mA = 0-100% RH 12 mA = 50% RH. • Measure for normal 1-5 VDC range on Control RH transmitter or 4-20 mA by others: 22 +, 23-
6	Humidistat fault	<ul style="list-style-type: none"> • Open, shorted, or incorrect wiring of transmitter or humidistat 	<ul style="list-style-type: none"> • Check D.C. supply voltage terminals: 21+, 23-(21 VDC)
		<ul style="list-style-type: none"> • Signal by others. Incorrect, out of range or miswired. 	<ul style="list-style-type: none"> • If there is no output, 4-20 mA, replace transmitter. Transmitter by others is not compatible. Consult DRI-STEEM.
		<ul style="list-style-type: none"> • Ground loop 	<ul style="list-style-type: none"> • Isolation board by others.
		<ul style="list-style-type: none"> • Control signal by others has exceeded the range limits. Correct control signal to 4-20 mA, 0-135 Ohms, or 0-15 VDC. 	<ul style="list-style-type: none"> • Recalibrate if there is a calibration error: Normal Range 4-20 mA = 0-100% RH 12 mA = 50% RH. • Measure for normal 1-5 VDC range on Control RH transmitter or 4-20 mA by others: 22 +, 23-

More on next page ...

Troubleshooting guide.

Problem number	Problem	Possible cause	Action
7	VAV humidity transmitter fault	<ul style="list-style-type: none"> Incorrect high limit transmitter wiring 	<ul style="list-style-type: none"> HL input 2, shunt connector J27 across "I" pins. Measure normal 1-5 VDC range on control HL 25+, 26-.
8	Temp comp transmitter fault	<ul style="list-style-type: none"> Incorrect high limit transmitter wiring 	<ul style="list-style-type: none"> Temperature input 3, shunt connector J11 across "I" pins. Check D.C. supply voltage terminals 27+, 29- (21VDC) Measure normal 1-5 VDC range on temperature transmitter +28, -29. Temperature transmitter -20 degrees F - 160 degrees F should have 12 mA = 70 degrees F part No. 405889.
9	Fill fault	<ul style="list-style-type: none"> When in the fill sequence, VAPOR-LOGIC allows 40 minutes for the water to reach the maximum upper water level. If the water does not reach the designated level, and the probe system is not satisfied, a fault will be indicated. 	<ul style="list-style-type: none"> Check water shut-off valve. If closed, open the valve. Check the in-line strainer, clean as needed. Check for proper wiring of humidifier cover interlock switch. Check if there is 24 VAC present across fill valve coil. If yes, replace valve. Verify proper fill valve wiring terminal 1, 2, initiate a VAPOR-LOGIC test cycle. Clean or replace probe Check if needle valve is open and/or free of sediment. Low conductivity water minimum 2 grains/gallon. Add salt to increase water conductivity. Check if humidifier overtemperature switch is reset and/or properly wired. Electrical noise. Low voltage fill valve wiring routed with high voltage conduit wiring. Incorrect operating voltage fill valve installed. Valve coil should be 24 VAC. <p style="text-align: right;">More on next page ...</p>

Troubleshooting guide.

Problem number	Problem	Possible cause	Action
(continued) 9	(continued) Fill fault	(continued) <ul style="list-style-type: none"> When in the fill sequence, VAPOR-LOGIC allows 40 minutes for the water to reach the maximum upper water level. If the water does not reach the designated level, and the probe system is not satisfied, a fault will be indicated. 	<ul style="list-style-type: none"> Low water supply pressure minimum 170 kPa. Remove fill valve and check for any foreign material plugging valve. Fill valve may be plumbed backwards. Note flow direction and correct as needed.
		<ul style="list-style-type: none"> Fill and drain valve wiring reversed. 	<ul style="list-style-type: none"> Check wiring diagram.
10	Drain fault	<ul style="list-style-type: none"> When in auto drain sequence or end-of-season drain, VAPOR-LOGIC allows 20 minutes for the water level to drop from the top probe to below the lowest probe. If the tank does not drain to this level in the time allotted, a fault will be indicated. 	<ul style="list-style-type: none"> Check drain valve wiring. Check for voltage present at the valve. If present, clean or replace valve. Check if the tank drain outlet from humidifier is plugged. Clean. Reset VAPOR-LOGIC.
		<ul style="list-style-type: none"> Water detection probes. 	<ul style="list-style-type: none"> Clean probe tips or replace probe rod assembly.
		<ul style="list-style-type: none"> Drain valve wiring. 	<ul style="list-style-type: none"> Check to be sure drain valve is wired to correct terminals 3, 4 on control board.
		<ul style="list-style-type: none"> Fill valve. 	<ul style="list-style-type: none"> Leaking water through.
			More on next page ...

Troubleshooting guide.

Problem number	Problem	Possible cause	Action
(continued) 10	(continued) Drain fault	<ul style="list-style-type: none"> • System programmed for manual drain 	<ul style="list-style-type: none"> • Run a test cycle to see if system activates drain output.
		<ul style="list-style-type: none"> • Drain line backing up with water. 	<ul style="list-style-type: none"> • Insufficient drain line pitch. • Insufficient drain line size, 31 mm minimum for distance over 3 m.
11	Low water timer fault	<ul style="list-style-type: none"> • Fill valve is stuck open. 	<ul style="list-style-type: none"> • Check valve for foreign matter.
		<ul style="list-style-type: none"> • Fill valve is installed backwards. 	<ul style="list-style-type: none"> • Check arrow direction on strainer. “In” should be visible on fill valve body.
		<ul style="list-style-type: none"> • Water probes have not proven. 	<ul style="list-style-type: none"> • Drain valve may be stuck open. Clean or replace valve. • Water is not conductive for probe system. Add salt or convert to DI control.
12	LL probe fault	<ul style="list-style-type: none"> • Low conductivity water supply 	<ul style="list-style-type: none"> • Two grains/gallon minimum. Add salt. • Measure zero Volt A.C. from probes to ground when water is in contact with probes.
		<ul style="list-style-type: none"> • Humidifier overtemperature thermostat 	<ul style="list-style-type: none"> • Reset manual thermostat switch • Thermostat switch not wired
		<ul style="list-style-type: none"> • Humidifier interlock cover switch 	<ul style="list-style-type: none"> • Switch not wired • Install humidifier cover. • Adjust switch for proper closure.
		<ul style="list-style-type: none"> • Probes 	<ul style="list-style-type: none"> • Clean probe tips.
		<ul style="list-style-type: none"> • Improper water level changes inside tank 	<ul style="list-style-type: none"> • Verify proper wiring of probe system. Shielded type wiring is not recommended • Probe wiring routed with high voltage wiring.

More on next page ...

Troubleshooting guide.

Problem number	Problem	Possible cause	Action
(continued) 12	(continued) LL probe fault	(continued) <ul style="list-style-type: none"> Improper water level changes inside tank 	<ul style="list-style-type: none"> Wiring between control cabinet and humidifier exceeds the recommended 50 foot limit. Check fill and drain plumbing installation.
		<ul style="list-style-type: none"> Water in tank oscillates or jumps 	<ul style="list-style-type: none"> Back pressure from dispersion system, distance, elbows, restrictions. No “P” trap installed on tank and/or plugged.
		<ul style="list-style-type: none"> Over boiling or foaming of water in tank. 	<ul style="list-style-type: none"> Poor maintenance, tank needs cleaning. Chemical used to clean tank not recommended, drain and rinse tank thoroughly.
13	ML probe fault	<ul style="list-style-type: none"> Low conductivity water supply 	<ul style="list-style-type: none"> Two grains/gallon minimum. Add salt. Measure zero Volt A.C. from probes to ground when water is in contact with probes.
		<ul style="list-style-type: none"> Humidifier overtemperature thermostat 	<ul style="list-style-type: none"> Reset manual thermostat switch Thermostat switch not wired
		<ul style="list-style-type: none"> Humidifier interlock cover switch 	<ul style="list-style-type: none"> Switch not wired Install humidifier cover. Adjust switch for proper closure.
		<ul style="list-style-type: none"> Probes 	<ul style="list-style-type: none"> Clean probe tips.
		<ul style="list-style-type: none"> Improper water level changes inside tank 	<ul style="list-style-type: none"> Verify proper wiring of probe system. Shielded type wiring is not recommended Probe wiring routed with high voltage wiring. Wiring between control cabinet and humidifier exceeds the recommended 50 foot limit. Check fill and drain plumbing installation.

More on next page ...

Troubleshooting guide.

Problem number	Problem	Possible cause	Action
(continued) 13	(continued) ML probe fault	<ul style="list-style-type: none"> Water in tank oscillates or jumps 	<ul style="list-style-type: none"> Back pressure from dispersion system, distance, elbows, restrictions. No “P” trap installed on tank and/or plugged.
		<ul style="list-style-type: none"> Over boiling or foaming of water in tank. 	<ul style="list-style-type: none"> Poor maintenance, tank needs cleaning. Chemical used to clean tank not recommended, drain and rinse tank thoroughly.
14	Replace probes fault	<ul style="list-style-type: none"> Low water conductivity minimum 2 grains/gallon 	<ul style="list-style-type: none"> Check conductivity. Add salt
		<ul style="list-style-type: none"> System has detected a need to clean or replace probe. 	<ul style="list-style-type: none"> Remove and clean probe rod tips. Drain tank of water below probe, then re-set system and re-start. Low water conductivity minimum 2 grains/gallon hardness, add salt.
		<ul style="list-style-type: none"> Mineral buildup on probe rod 	<ul style="list-style-type: none"> Clean probe rod tips.
		<ul style="list-style-type: none"> Incorrect wiring of probe 	<ul style="list-style-type: none"> Check for proper wiring Do not use shielded cable. Probe wires routed with high voltage wires must be separated.
		<ul style="list-style-type: none"> Humidifier interlock switches and/or overtemperature thermostat 	<ul style="list-style-type: none"> Switch or thermostat not wired. Interlock switch not set correctly or humidifier cover off. Overtemp thermostat not reset.
		<ul style="list-style-type: none"> Deterioration of probe rod assembly 	<ul style="list-style-type: none"> Replace probe rod assembly.
		<ul style="list-style-type: none"> Probe signal too low 	<ul style="list-style-type: none"> With water off the probe, measure 2.5 VAC from each probe to ground.
			More on next page ...

Troubleshooting guide.

Problem number	Problem	Possible cause	Action
(continued) 14	(continued) Replace probes fault	<ul style="list-style-type: none"> Probe wiring. 	<ul style="list-style-type: none"> Check for proper wiring. Machine ground must be present between control cabinet and humidifier tank. Do not use shield cable. Individual 1 mm². standard wire is recommended. Maximum wiring distance is 15 m from humidifier to control cabinet.
		<ul style="list-style-type: none"> Reset to clear message 	<ul style="list-style-type: none"> Drain humidifier tank completely, reset VAPOR-LOGIC to restart system.
		<ul style="list-style-type: none"> Poor continuity 	<ul style="list-style-type: none"> No machine ground between control cabinet and humidifier tank
15	Probe assembly fault	<ul style="list-style-type: none"> Deterioration of probe rod assembly 	<ul style="list-style-type: none"> Replace probe rod assembly.
16	Temperature sensor fault	<ul style="list-style-type: none"> Open, shorted, or incorrect wiring of sensor 	<ul style="list-style-type: none"> Check wiring terminals (VAPOR-LOGIC[®]₃ terminal J25) for correct wiring and voltages.
17	Thermal trip fault	<ul style="list-style-type: none"> Unit has overheated. 	<ul style="list-style-type: none"> Check for proper water level in tank.
18	SDU fault	<ul style="list-style-type: none"> SDU blower or AFPS is incorrectly wired. 	<ul style="list-style-type: none"> Check SDU for proper wiring.
		<ul style="list-style-type: none"> SDU blower motor is defective (SDU fan does not start). 	<ul style="list-style-type: none"> Replace SDU blower.

More on next page ...

Troubleshooting guide.

Problem number	Problem	Possible cause	Action
19	EEPROM fault	<ul style="list-style-type: none"> Internal program changed (VAPOR-LOGIC₃ detected a change from its previous program check) 	<ul style="list-style-type: none"> Consult DRI-STEEM for reprogramming instructions.
20	Flue fault	<ul style="list-style-type: none"> The combustion air damper is incorrectly wired or has failed to open. 	<ul style="list-style-type: none"> Check for proper combustion air damper wiring.
		<ul style="list-style-type: none"> The power vent pressure switch is incorrectly wired or the power vent has failed to start. 	<ul style="list-style-type: none"> Check for proper power vent wiring.
21	Burner No. fault	<ul style="list-style-type: none"> No gas supply to unit 	<ul style="list-style-type: none"> Verify that gas service valve is on and receiving minimum pressure to manifold per rating plate.
		<ul style="list-style-type: none"> Gas valve is off or there is no power to the valve. 	<ul style="list-style-type: none"> Verify that valve is in “on” position and that there is power to the valve.
		<ul style="list-style-type: none"> Broken ignitor 	<ul style="list-style-type: none"> Verify that ignitor glows.
		<ul style="list-style-type: none"> Gas valve/ignitor/sensing electrode is out of sequence 	<ul style="list-style-type: none"> Verify wire connections to these components.
		<ul style="list-style-type: none"> Gas valve outlet pressure is too low. 	<ul style="list-style-type: none"> Verify out pressure is set per rating plate.
		<ul style="list-style-type: none"> Blower inlet is dirty or obstructed. 	<ul style="list-style-type: none"> Clean inlet and check for obstructions.

More on next page ...

Troubleshooting guide.

Problem number	Problem	Possible cause	Action
22	Ignitor No. fault	<ul style="list-style-type: none"> • Broken ignitor 	<ul style="list-style-type: none"> • Verify that ignitor glows.
		<ul style="list-style-type: none"> • Gas valve/ignitor/sensing electrode is out of sequence. 	<ul style="list-style-type: none"> • Verify wire connections to these components.
23	Blower No. fault	<ul style="list-style-type: none"> • The blower is incorrectly wired or the blower failed to start. 	<ul style="list-style-type: none"> • Check for proper blower wiring.
24	Slave No. fault	<ul style="list-style-type: none"> • LonTalk® communications cable is not connected between boards. 	<ul style="list-style-type: none"> • Connect LonTalk communications cable.
		<ul style="list-style-type: none"> • Slave board does not have power or has incorrect power. 	<ul style="list-style-type: none"> • Verify power wiring on slave board.
25	Control does not energize.	<ul style="list-style-type: none"> • Nonexistent supply voltage to unit 	<ul style="list-style-type: none"> • Check main line fuse. • Check main line safety switch. • Check heater fuses.
		<ul style="list-style-type: none"> • Nonexistent control voltage 	<ul style="list-style-type: none"> • Check for proper supply. • Verify proper transformer voltage characteristics. • Verify proper wiring of transformer. • Check for control circuit voltage, 24 VAC. If voltage is not present, check transformer circuit breaker. Reset if needed.
		<ul style="list-style-type: none"> • Heater over-temperature thermostat open 	<ul style="list-style-type: none"> • Reset manual switch located above heater or humidifier cover.

More on next page ...

Troubleshooting guide.

Problem number	Problem	Possible cause	Action
26	Unit does not fill with water.	<ul style="list-style-type: none"> Malfunctioning fill valve 	<ul style="list-style-type: none"> First, disconnect brown wire and then the orange wire from VAPOR-LOGIC[®]₃ board terminals 30 and 31 of terminal block J8. Fill valve should open. If fill valve does not open, verify proper 24 VAC (terminals 1 and 2) to fill valve. If voltage is present and valve does not open, replace valve or valve coil. Verify that coil is 24 VAC. Verify that valve stem moves freely.
		<ul style="list-style-type: none"> No water supply to fill valve 	<ul style="list-style-type: none"> Check if water supply line strainer is plugged. Verify that manual water line shut-off valve is open and that pressure exists.
		<ul style="list-style-type: none"> Unit is not in auto mode. 	<ul style="list-style-type: none"> Go to Control Modes screen and select Auto Mode.
		<ul style="list-style-type: none"> VAPOR-LOGIC[®]₃ control is in “end of season” drain mode. 	<ul style="list-style-type: none"> Check for humidity demand (VAPOR-LOGIC₃ control board terminals 21, 22 and 23 of terminal block J26).
		<ul style="list-style-type: none"> Malfunctioning level control system 	<ul style="list-style-type: none"> Disconnect brown and orange wires connected to VAPOR-LOGIC₃ board terminals 30 and 31 of terminal block J8. If fill valve does not open, check for proper 24 VAC (terminals 1 and 2) to fill valve coil. If proper voltage is not present, the control board is defective. Check terminals 30, 31, 32 and 33 on VAPOR-LOGIC₃ control board terminal block J8 for correct voltage: <ul style="list-style-type: none"> 32 (purple) to 33 (yellow), no water present > 2 VAC 32 (purple) to 33 (yellow), water present < 1/4 VAC 31 (orange) to 33 (yellow), same readings as above 30 (brown) to 33 (yellow), same readings as above
		<ul style="list-style-type: none"> Inlet water needle valve is closed. 	<ul style="list-style-type: none"> Check needle valve.

More on next page ...

Troubleshooting guide.

Problem number	Problem	Possible cause	Action
27	Fill valve does not close	<ul style="list-style-type: none"> • Open drain valve <hr style="border-top: 1px dashed black;"/> • Malfunctioning level control system 	<ul style="list-style-type: none"> • If automatic drain valve is locked in manual open position, reset to automatic. • Replace valve if there is a broken return spring on the drain valve. • Clean or replace drain valve if an obstruction in the valve will not allow complete closure. • Close manual drain valve, if it is open. • If VAPOR-LOGIC[®]₃ shorted output to fill valve coil, replace board. <hr style="border-top: 1px dashed black;"/> • Check if probe head is fully plugged in. • If needed, clean probe rod tips. • Verify if VAPOR-LOGIC₃ control board with nylon mounting standoffs terminal 33 needs to be grounded. • If there is low water conductivity, add salt to tank water. (If this solves the problem, consult DRI-STEEM for further advice.) • Replace board if VAPOR-LOGIC₃ control board is defective. • Verify that system is in auto mode. • Verify that probe is wired correctly. • Check terminals 30, 31, 32 and 33 on VAPOR-LOGIC₃ control board terminal block J8 for correct voltage: <ul style="list-style-type: none"> – 32 (purple) to 33 (yellow), no water present > 2 VAC – 32 (purple) to 33 (yellow), water present < 1/4 VAC – 31 (orange) to 33 (yellow), same readings as above – 30 (brown) to 33 (yellow), same readings as above

More on next page ...

Troubleshooting guide.

Problem number	Problem	Possible cause	Action
(continued) 27	(continued) Fill valve does not close	<ul style="list-style-type: none"> • Fill valve is stuck 	<ul style="list-style-type: none"> • Check if fill valve is installed backwards. If yes, repipe. • If there is a faulty internal spring or diaphragm in the fill valve, replace valve. • Check if there is an obstruction that will not allow valve to seat properly. Clean or replace valve as needed. • Check for control voltage across fill valve coil. (Check wiring and controls.)
28	Reduced or no output (even though water level is correct)	<ul style="list-style-type: none"> • Heater malfunctioning 	<ul style="list-style-type: none"> • Verify that proper voltage is being applied to heaters. • Check heater amperage. • If heater contactor is not functioning, replace.
		<ul style="list-style-type: none"> • Malfunctioning control system 	<ul style="list-style-type: none"> • Check if heater fuses are blown and replace if required. • Check if auxiliary limit controls are not allowing system to operate (i.e., duct humidistats, air flow proving switch, etc.). Reset, replace or calibrate as needed. (Air flow switch, terminals 12 and 13, measures 24 VAC if open. On-off high limit, terminals 25 and 26, measures 21 VDC if open.) • Check if the (optional) heater over-temperature thermostat has been tripped. Reset if necessary. • Replace zone valve if end switch is not closing.

More on next page ...

Troubleshooting guide.

Problem number	Problem	Possible cause	Action
29	Fill valve cycles on and off frequently (several times per minute).	<ul style="list-style-type: none"> Malfunctioning level control system 	<ul style="list-style-type: none"> If needed, clean probe tips. Check water conductivity. (Minimum conductivity for proper operation of level control system is 100 microSiemens per cm.) Verify that probe wiring is correct.
		<ul style="list-style-type: none"> Drain valve not fully closed 	<ul style="list-style-type: none"> If an obstruction will not allow drain valve to fully close, clean valve. If there is a broken or weak return spring on drain valve, replace the valve. Check if 24 VAC is present at valve. If so, check wiring of VAPOR-LOGIC[®]₃ control board terminals 3 and 4.
30	Heater burnout	<ul style="list-style-type: none"> Water level is too low. 	<ul style="list-style-type: none"> Check probes and clean tips if necessary. Clean probe still-well area in tank. Check drain valve and clean, repair, or replace as needed.
		<ul style="list-style-type: none"> Improper wiring 	<ul style="list-style-type: none"> Verify proper voltage applied to heater. Verify proper electrical connections.
		<ul style="list-style-type: none"> Mineral buildup impeding heat transfer to water 	<ul style="list-style-type: none"> Inspect tank for severe mineral buildup on or around heater. Increase skimming quantity, frequency of drain cycle, and/or frequency of cleaning. Use softened makeup water.
		<ul style="list-style-type: none"> Heater corrosion 	<ul style="list-style-type: none"> Inspect heater for surface corrosion or pitting. If evident, consult DRI-STEEM.

More on next page ...

Troubleshooting guide.

Problem number	Problem	Possible cause	Action
31	Noisy operation	<ul style="list-style-type: none"> • “Thunder”-type noise coming from tank during refill 	<ul style="list-style-type: none"> • Normal on larger units, caused by the cold fill water collapsing steam in the tank. Reduce kPa (minimum of 172 kPa) if inlet water pressure is too high.
		<ul style="list-style-type: none"> • Contactor noise 	<ul style="list-style-type: none"> • Contactor normally makes a “clunk” as it pulls in. A continuous chattering noise is not normal and is symptomatic of a failing contactor or malfunctioning controls. Replace contactor or troubleshoot the control system.
		<ul style="list-style-type: none"> • Fill valve noise 	<ul style="list-style-type: none"> • A clicking sound as fill valve opens or closes and a hissing sound during fill are normal. A slamming sound as fill valve closes is “water hammer” and can be minimized by installing a shock arrester. • A loud buzzing sound indicates poor alignment of valve stem. Replace valve.
32	Humidity below desired level	<ul style="list-style-type: none"> • Unit operating but fails to meet required humidity output 	<ul style="list-style-type: none"> • Unit undersized; replace with a larger unit or add additional humidifier. • Skimmer rate is too high. • If drain valve will not close fully, determine the cause and clean, repair or replace as needed. • If drain pipe water seal is allowing steam to go down the drain, repair as needed. • If there is an improper water seal height, increase to recommended height. (See humidifier tank manual.) • If there is excessive internal steam pressure, determine the cause of the high pressure (e.g., high duct static pressure, undersized orifices in dispersion tubes, water, or crushed vapor hose) and repair as required. • Replace leaking gasket or vapor hose. • Recalibrate if controls are out of calibration. • If fill valve is stuck open, repair or replace. • If zone valve will not open, repair or replace. <p style="text-align: right;">More on next page ...</p>

Troubleshooting guide.

Problem number	Problem	Possible cause	Action
<p>(continued) 32</p>	<p>(continued) Humidity below desired level</p>	<ul style="list-style-type: none"> • No call for humidity from humidistat or from control and high limit humidity transmitters <hr style="border-top: 1px dashed black;"/> • Excessive outside air volume <hr style="border-top: 1px dashed black;"/> • Heating elements not operating <hr style="border-top: 1px dashed black;"/> • Humidity control input type not the same as VAPOR-LOGIC₃ software 	<ul style="list-style-type: none"> • Low or no signal strength from humidistat. Check for proper wiring. • Check humidity transmitters (4-20 mA output). • Adjust set point if VAPOR-LOGIC₃ set point is too low. <hr style="border-top: 1px dashed black;"/> • Verify proper operation of fans, dampers, VAV systems, etc. <hr style="border-top: 1px dashed black;"/> • If heaters are burned out, refer to Problem No. 30 “Heater burnout.” • Verify that humidistat is calling for humidity. • Check for control voltage if limit controls (air flow proving switch, zone valves, etc.) are not allowing unit to operate. • Check fuses and replace if they are blown. • Check if the (optional) heater over-temperature has been tripped. Reset if necessary. <hr style="border-top: 1px dashed black;"/> • Check VAPOR-LOGIC₃ control board connections J26, J27 and J28. Consult DRI-STEEM. <p style="text-align: right;">More on next page ...</p>

Troubleshooting guide.

Problem number	Problem	Possible cause	Action
33	Humidity above set point	• High entering relative humidity	• Dehumidify.
		• Unit oversized	• Consult DRI-STEEM.
		• Reduced air flow	• Check fans, dampers, VAV systems, etc.
		• Improperly located humidistat or humidity transmitters	• Relocate using guidelines established in this manual (see Pages 16-23).
		• Malfunctioning controls	<ul style="list-style-type: none"> • Check for incorrect supply voltage. • Check for incorrect control signal. • Check for improper wiring hookup. • If humidity controller or transmitter are out of calibration or malfunctioning, repair or recalibrate. • If zone valve end switch is not opening, repair or replace. • Check if SSR shorted. Repair or replace as needed.
34	Hunting (humidity swings above and below desired set point)	• Malfunctioning control system	<ul style="list-style-type: none"> • If there is a faulty or inaccurate humidity controller or transmitter, repair or replace. • Check for proper VAPOR-LOGIC[®]₃ control settings: RH set point, HL set point, cycle rate, PID tuning, etc. • Relocate poorly located control components. See humidity control placement information on Pages 16-23 for recommendations. • If inappropriate control components are being used, change components. • On SSR units: Control wire and power wires must be physically separated from each other. If they are not, an induced control voltage may occur, causing erratic operation. • Verify that 6-wire modular cable is isolated from power wiring.

More on next page ...

Troubleshooting guide.

Problem number	Problem	Possible cause	Action
(continued) 34	(continued) Hunting (humidity swings above and below desired set point)	• Air volume is varying rapidly.	• Stabilize.
		• Air temperature is varying rapidly.	• Stabilize to $\pm 1^{\circ}\text{C}$.
35	Unit does not perform autodrain sequence	• System may not have automatic drain system	• Inspect unit to verify that automatic drain valve was furnished.
		• Drain fault, plugged drain valve or plugged drain pipe	• Clean drain valve piping.
		• Malfunctioning autodrain sequence	• Check VAPOR-LOGIC ₃ main menu settings and reset if necessary.
		• No power to automatic drain valve	• Check if 24 VAC is present at VAPOR-LOGIC ₃ control board terminals 3 and 4 and drain valve.
		• Defective automatic drain valve	• Valve should be replaced if voltage is present at valve and it still does not open.
36	Tank does not heat up	• Overtemperature thermostat switch located under heater wiring cover	• Reset thermostat switch.
		• Humidifier cover interlock switch	• Humidifier cover (VLC, VLDI) not wired, adjust interlock switch.

More on next page ...

Troubleshooting guide.

Problem number	Problem	Possible cause	Action
(continued) 36	(continued) Tank does not heat up	<ul style="list-style-type: none"> • Incorrect or nonexistent control voltage 	<ul style="list-style-type: none"> • Check for proper supply voltage on electrical diagram. • Verify proper transformer voltage characteristics. • Verify proper wiring of transformer . • Check for control circuit voltage on electrical diagram. If voltage is not present, troubleshoot boards and wiring system for potential short circuit.
		<ul style="list-style-type: none"> • Incorrect or nonexistent supply voltage to the unit 	<ul style="list-style-type: none"> • Check main-line fuse. • Check main-line safety switch. • Check heater fuses, electrical diagram
37	Unit does not perform auto-drain sequence	<ul style="list-style-type: none"> • Test cycle 	<ul style="list-style-type: none"> • Initiate a test cycle to see if drain valve is cycled open then closed. If not, system needs to be re-programmed.
		<ul style="list-style-type: none"> • System may not have automatic drain system 	<ul style="list-style-type: none"> • Inspect unit to verify that automatic electric drain valve was furnished.
		<ul style="list-style-type: none"> • VAPOR-LOGIC program 	<ul style="list-style-type: none"> • Program may be for manual drain
		<ul style="list-style-type: none"> • Drain fault, plugged drain valve or plugged drain pipe. 	<ul style="list-style-type: none"> • Clean drain valve piping.
		<ul style="list-style-type: none"> • Malfunctioning auto drain sequence 	<ul style="list-style-type: none"> • Check VAPOR-LOGIC main menu settings and re-set if necessary.
		<ul style="list-style-type: none"> • No power to automatic drain valve 	<ul style="list-style-type: none"> • Check if 24 VAC is present at drain valve. If not, replace board.
		<ul style="list-style-type: none"> • Defective automatic drain valve 	<ul style="list-style-type: none"> • Valve should be replaced if voltage is present at valve and it still does not open.
			More on next page ...

Troubleshooting guide.

Problem number	Problem	Possible cause	Action
38	Unit does not perform end of season drain	• Input signal always has a demand	• Reduce demand signal.
		• VAPOR-LOGIC program	• Program may be arranged for manual drain. Run a test cycle to see if system operates drain valve.
		• Drain valve	• Valve not wired to or incorrectly wired to control board.
		• Drain valve	• Faults check 24 VAC across valve coil during test cycle.
39	Humidifier tank has proper water level and is always warm	• Aquastat	• Normal, aquastat is maintaining a certain water temperature in tank range 4 - 82°C. • Re-adjust aquastat temperature to low set point.
		• Heating element	• Shorted to ground passing current. Check replace
		• SCR Power Controller	• SCR control devices shorted close, check replace • Phase to phase wiring crossed
		• Contactor	• Contactor shorted closed, check replace

More on next page ...

Replacement parts.

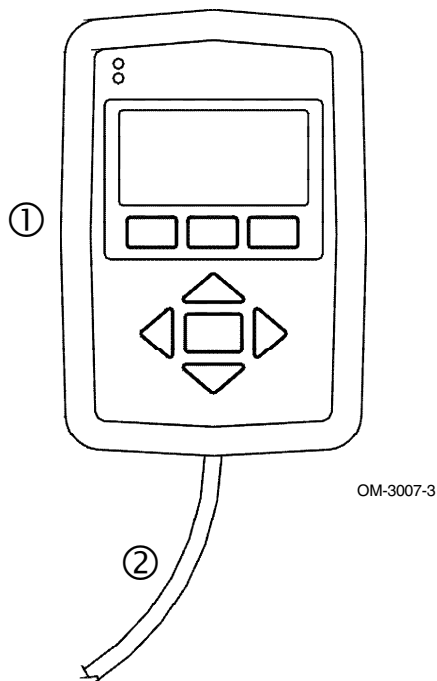

No.	Description	Qty.	Part No.
1	Display board	1	408490-002
2	Cable	1	408490-*
3	Main board	1	408490-001

*Part number varies with cable length. Specify humidifier model and serial number when ordering.

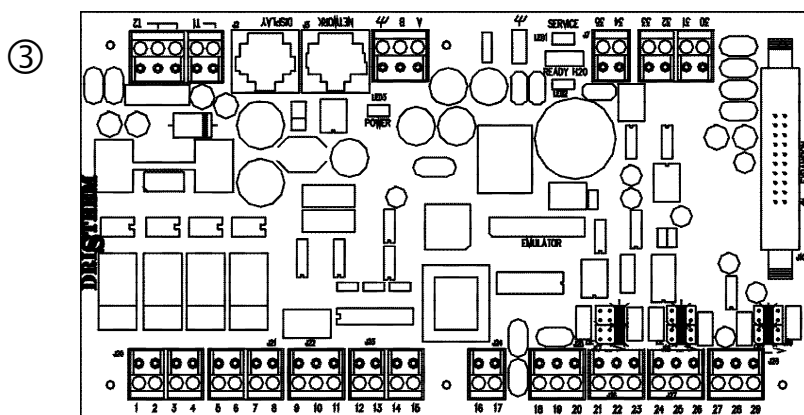

OM-VL3-3

Operation

Notes.

Operation

Notes.

Operation

Notes.

DRI-STEEM HUMIDIFIER COMPANY

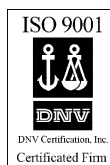

14949 Technology Drive • Eden Prairie, MN 55344
Phone: (952) 949-2415 • Fax: (952) 229-3200
E-Mail: sales@dristeem.com • Web: www.dristeem.com

European Office:

Bell Place, Bell Lane • Syresham, Brackley • NN13 5HP, U.K.
Phone: +44 1280 850122 • Fax: +44 1280 850124
E-Mail: 106277.1443@compuserve.com

Continuous product improvement is a policy of The DRI-STEEM Humidifier Company therefore,
product features and specifications are subject to change without notice.

VAPOR-LOGIC, GTS, STS, LTS, CRUV, VAPORSTREAM, VAPORMIST, ULTRA-FOG and ULTRA-SORB
are registered trademarks of The DRI-STEEM Humidifier Company.