

READ AND SAVE THESE INSTRUCTIONS.

VAPORSTREAM[®] MODEL "D.I."

ELECTRIC STEAM HUMIDIFIERS

UL LISTED

IT'S DIFFERENT!!

**It's specially designed and built for use
with deionized (DI), demineralized,
or reverse osmosis (RO) water.**

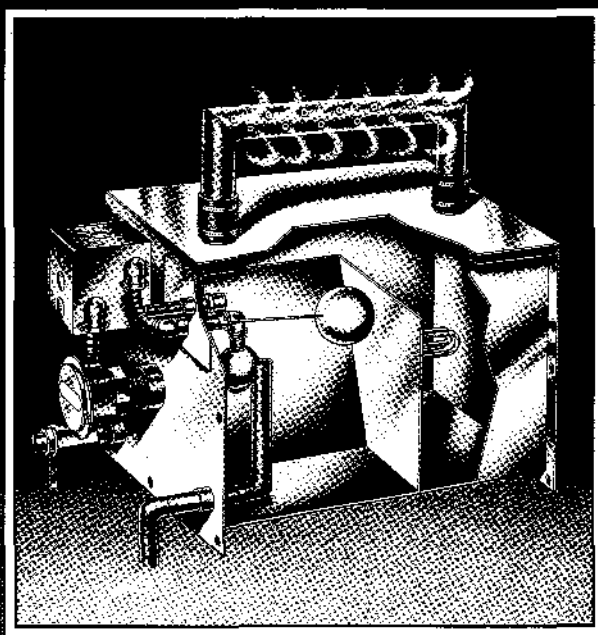

**INCLUDES INSTALLATION,
Maintenance/Operations
Manual**

DRI-STEEM
HUMIDIFIER COMPANY

Box 128 • Hopkins, Minnesota 55343

FORWARD

To the Purchaser and the Installer

Thank you for deciding to purchase Vaporstream equipment.

We have applied our best efforts to design and build this equipment to give you total satisfaction and many years of trouble free service.

Avoiding certain pitfalls during installation and observing proper operating practices thereafter will assure you of achieving that objective.

We therefore respectfully urge you to familiarize yourself with the contents of this bulletin.

Dri-Steem Humidifier Company

Table of Contents

Forward and Table of Contents	Page 2
Vaporstream Cutaway and Description	Pages 3 & 4
Mechanical and Electrical Specifications	Page 5
Humidifier Location Selection	Pages 6 & 7
Designed to Work Anywhere	Page 8
Humidifier Mounting	Page 9
Piping Direction	Pages 10 & 11
Installing the Vaporstream	Page 12
Start Up, Check Out Procedures and Recommended Maintenance	Page 12
Control Cabinet Parts List	Page 13
Components Parts List	Page 14
Wiring Diagram	Page 15
Maintenance Service Record	Page 16
Vaporstream Warranty	Page 16

VAPORSTREAM MODEL "D.I." ELECTRIC STEAM HUMIDIFIER

Recommended for use with deionized water having a maximum resistance of 18 megohms/centimeter at 25°C (77°F).

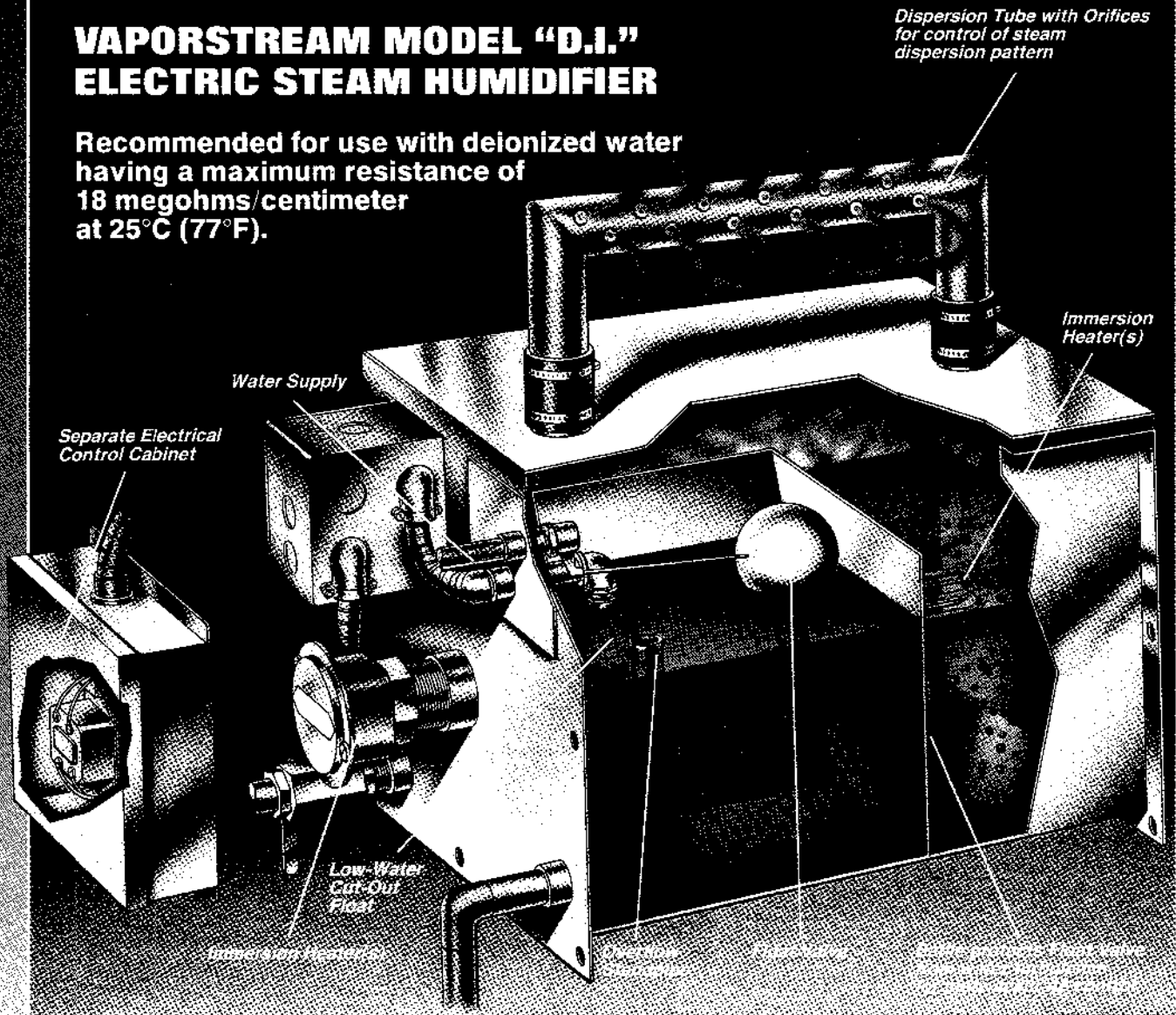

Model "D.I." on separate stand with single hose connection to steam dispersion tube in duct

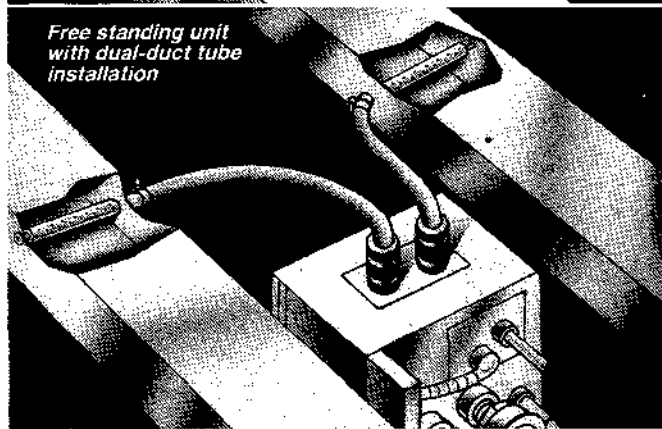

Free standing unit with dual-duct tube installation

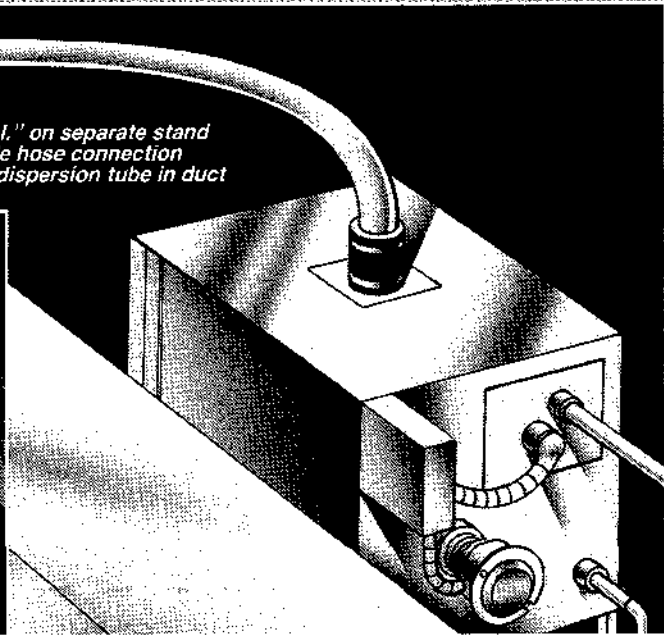

Today's Technological Requirements Demand Reliable, Accurate Humidification.

Microchip manufacturing ... computers ... medical facilities ... food processing ... aerospace technology ... more and more of our technological world requires accurate, reliable humidification as part of a sanitary, climate-controlled environment. And many of these environments also require — or already have available — demineralized, deionized (DI) water or reverse osmosis (RO) water. This is "purified" water ... the dissolved minerals have been removed.

The VAPORSTREAM Model "D.I." electric steam humidifier is specially designed and built to be used with this special type of water.

Corrosion Resistant Construction Lasts A Long, Long, Time.

Water, in its pure state, is an extremely active solvent.

When it is pumped from the earth, its appetite has usually been satisfied with mineral salts absorbed while it was in the ground.

Later, when these minerals have been removed by either the deionizing or reverse osmosis process it reverts to its original hungry state.

If there are no mineral salts for it to attack, it goes to work on metals, sometimes voraciously.

Typical humidifier construction will not endure under these circumstances. Even some stainless steel alloys are not immune to attack.

The VAPORSTREAM Model "D.I." humidifier, however, is constructed of a special corrosion resistant *stainless steel* alloy that has been selected for this purpose. The heating elements are clad in this stainless steel and the control components are of stainless steel ... in fact, all the parts exposed to this corrosive water are made of this corrosion resistant stainless steel alloy. And special heli-arc welding techniques ensure corrosion-resistant joints.

The VAPORSTREAM Model "D.I." is built to last.

It's Virtually Maintenance-Free.

Since the VAPORSTREAM Model "D.I." unit uses mineral-free water, there is no need for a "dump cycle" to flush out the unit. No wasted heat energy and no wasted water.

No Wasted Water. No Wasted Heat. No Wasted Downtime.

Commercial evaporative humidifiers generally incorporate a "dump cycle" to flush out the concentration of dissolved minerals in the humidifier. Otherwise, rapid mineral build-up in the form of scum and scale requires frequent shut-downs for cleaning. This dump cycle represents a waste of water and heat energy (since the water that is dumped is HOT water).

Since the VAPORSTREAM Model "D.I." unit uses mineral-free water, there is no need for a "dump cycle" to flush out the unit. No wasted heat energy and no wasted water.

Continuous Modulating Output Provides Highly Accurate Control.

The elimination of the conventional "dump cycle" greatly improves the accuracy in control of humidity output.

During the time the conventional humidifier is dumping and refilling, no humidity is being produced. This allows the space humidity to drop.

In the Model "D.I.", on the other hand, the water is replaced continually as it evaporates so it is always "on the line". The steam output quantity can be made to vary, but doesn't have to start and stop.

Two excellent control systems are offered. The simplest, which does a good job, is a step control system. Multiple heating elements (two, three or four) are used. They are stepped on and off, one by one, to follow the changes in humidity load by varying the output.

The other method, though more costly, is used when the absolute ultimate in control accuracy is required. It uses an SCR system which provides continuous, infinitely modulating output control.

Designed To Fit Anywhere, Easy To Install.

The Model "D.I." needs just three services in order to function: demineralized water, electricity and drainage. The compact, stainless steel construction with a versatility in steam dispersers makes it adaptable to virtually all ducting conditions.

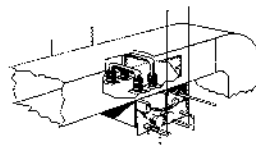

Unit mounted on the underside of a duct

The *simplest* application is to mount the unit at the underside of an air duct. Angle iron hangers and support rods support the weight of the humidifier. Either one or two small holes have to be cut in the duct floor to accommodate the dispersion tube (L-tube or inverted U-tube type), depending on the humidifier size.

Another very popular configuration is the free-standing unit, mounted on legs or on wall brackets, with steam hose(s) leading to the duct. A 1½" (38 mm) O.D. stainless steel dispersion tube(s) delivers steam to the active air stream in the duct.

The latter is a solid, practical solution to providing humidification in situations where space below ducts is not available for direct attachment of the unit. Single, double or triple hose arrangements are offered.

The Model "D.I." can also be mounted within an air handling unit.

OPTIONAL: Some air handling systems are difficult to humidify because the air travel distance available to absorb the vapor is so short. This can cause condensation in the duct or system. To minimize this vapor distance travel, VAPORSTREAM can provide multiple dispersion tube configurations to satisfy these requirements. For more information refer to pages 12-15 in the regular product catalog VSH 1286, or contact Dri-Steam or your Dri-Steam representative.

SELECTING THE LOCATION

A. It is very important that the humidifier be located where the water vapor being discharged will be carried off with the air stream and will not cause condensation or dripping from the duct.

B. In general, the electric evaporative humidifier is best placed where the air can most readily absorb the moisture being added without causing condensation at or after the unit. This will normally be after the heating coil or where the air temperature is highest.

C. Do not place in an outside air intake unless air is tempered with a preheat coil.

D. If the air passing over the humidifier will be cooler than 60°F., check the ability of the air to absorb the moisture. For example: 2000 CFM of air at 55°F. and 40% R.H. passes over a 6 KW humidifier that is adding 120,000 grains per hour.

The new condition after the humidifier is calculated as follows:

$$\frac{2000 \text{ (cfm)} \times 60 \text{ (min)}}{13.33 \text{ (cu. ft./lb.)}} = 9000 \text{ lbs. air}$$

9000 x 26 grains/lb (from Table 2-15)	= 234,000 grains
plus humidifier moisture	<u>120,000 grains</u>
Total moisture after humidifier	354,000 grains

$$354,000 \div 9000 \text{ lbs.} = 39 \text{ grains/lbs.}$$

From Table 2-15 it is seen that the new condition after the humidifier will be about 56°F. and 60% R.H. which means that the air is capable of absorbing the moisture being added.

E. Do not place the unit too near to the intake of a high efficiency filter. The filter will remove the visible moisture and become waterlogged. Allow at least 8 feet from the humidifier to the filter.

F. Do not place unit where discharged vapor will impinge on a metal surface. Allow at least 8 feet from the humidifier to such a surface.

G. Do not place the unit too close to a split in the duct. The unit may put more moisture in one branch than the other. Allow at least 8 feet from the humidifier to the split and center the humidifier upstream from the split.

When adequate distance is not available, you should use a rapid absorption tube bank. Refer to pages 12-15 in the VAPORSTREAM product catalog, or contact Dri-Steem or your Dri-Steem representative.

VAPOR ABSORPTION DISTANCE

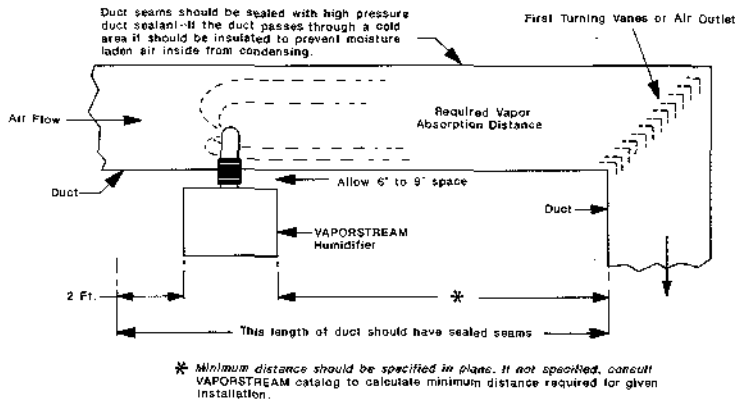

A distance of air travel is required for the steam to "disappear" or go into the gaseous state. While visible, the steam will collect on internal devices such as turning vanes resulting in dripping. A minimum of 8 feet is recommended.

INSTALLATION IN COOL AIR STREAM

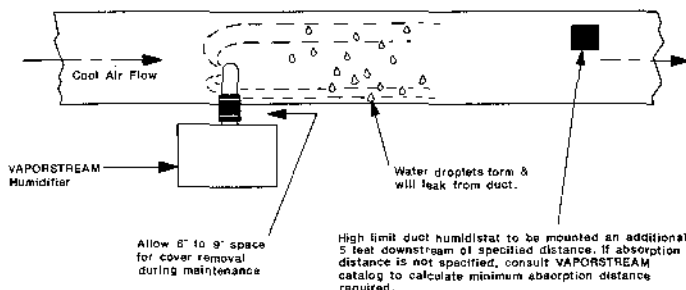

When a humidifier is installed in a duct that will carry cold air periodically, the dew point temperature should be determined. If the psychrometric chart reveals that saturation may occur, protection should be provided. A high limit humidistat or a thermostat, set to cut off the humidifier at a safe temperature, can be used for this purpose.

INSTALLATION ABOVE VALUABLE EQUIPMENT

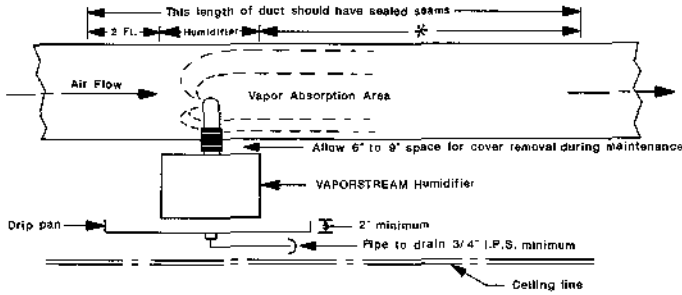

* Minimum distance should be specified in plans. If specified, consult VAPORSTREAM catalog to calculate minimum distance required for given installation.

Water piping and humidifiers should not be installed above expensive apparatus or equipment. A broken water pipe, leaking valve gland, condensation or other water leaks may occur causing serious damage and costly repairs to the equipment below.

Where this type of installation cannot be avoided install a drip tray constructed of galvanized sheet steel under the humidifier, valve, etc. to catch any possible water drip.

It is advisable to end the drain above an open floor drain. The overflow from the Vaporstream should be piped to a floor drain rather than the drip pan.

INSTALLATION AHEAD OF DUCT SPLIT

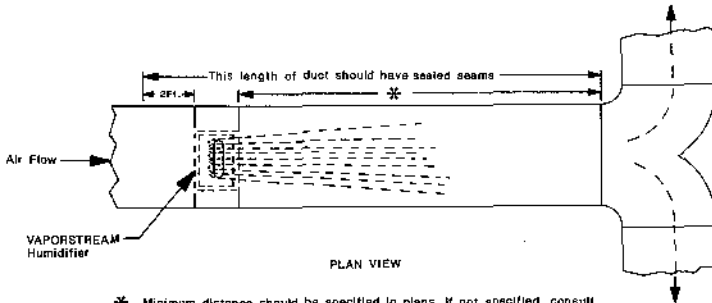

* Minimum distance should be specified in plans. If not specified, consult VAPORSTREAM catalog and calculate minimum distance required for given installation.

When a Vaporstream humidifier is installed upstream of a duct split, a minimum distance of 8 feet should be provided between the humidifier and the split. The humidifier should span most of the duct width or be centered upon it to equalize the humidifying effect between the two branches.

RECIRCULATION UNIT

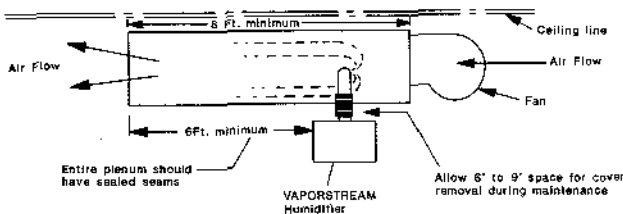

In an application where no duct system exists, or if the duct air is too cool for proper humidity absorption, a recirculation fan can be used. The fan circulates room temperature air across the Vaporstream humidifier and discharges humidified air into the space. The point of discharge should be carefully selected to avoid condensation on surfaces of the building or equipment.

DESIGNED TO WORK ANYWHERE

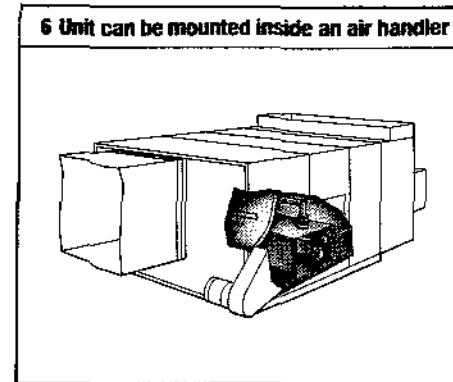
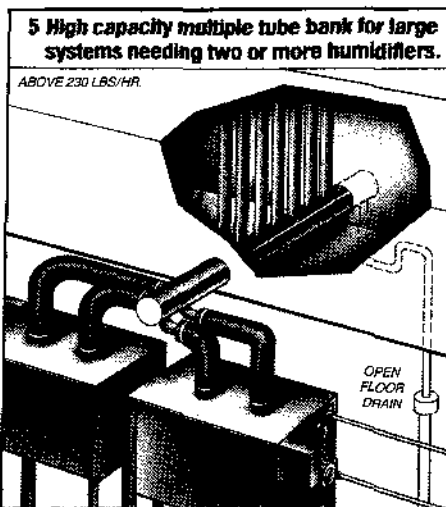
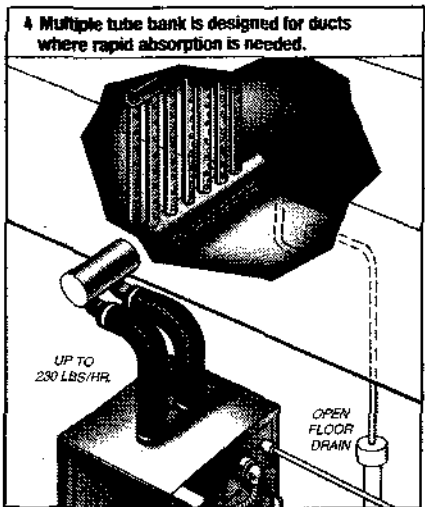
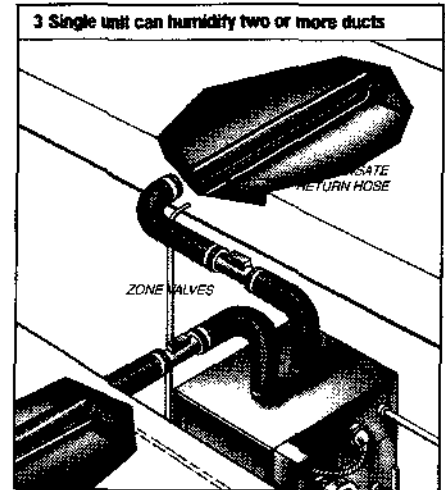
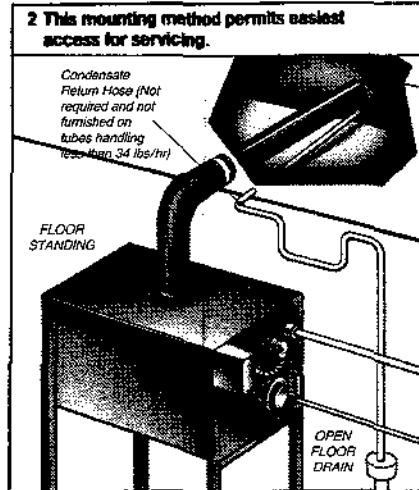
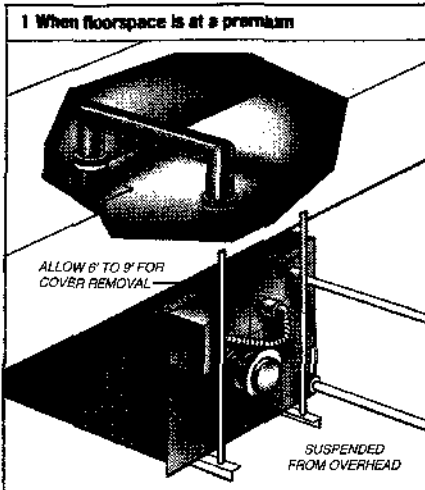

To put Vaporstream humidifiers to work, you need just three services: available tap water, available electricity, and a drain system. Vaporstream humidifiers are not designed to fit rigid, set situations, but are intended to adapt to varying conditions.

1. Mounting on Underside of Duct Conserves Floor Space.

Trapeze hangers and rods support the weight of the humidifier.

Two holes are required in the air duct floor to accommodate the inverted U-tube which extends into the active part of the air stream.

2-3. Remote Floor or Wall Mounted Unit with Vapor Hose.

The unit may be free-standing with legs or bracketed to the wall (options) in an accessible location with a vapor hose leading to the duct. 1½" O.D. stainless dispersion tube(s) delivers steam to the active part of the air stream.

Illustration 3 shows how two or more ducts can be served by a single humidifier. When individual room control is desired zone valves can be used.

4. Multiple-Tube Configurations for Rapid-Absorption Applications.

Total absorption of steam with no wetting of the duct interior is difficult to attain in some cases. Cool duct air and/or short absorption spaces are examples of this problem. A multiple dispersion tube bank such as this, that creates rapid and thorough mixing of steam and air is the answer to this problem.

5. Usually large systems often require two or more humidifiers to satisfy the load.

Specially designed dispersion tube banks for use with multiple steam hoses with a larger diameter lower header are available for these applications.

6. A Vaporstream can be installed directly inside an air handler or roof-top unit.

The holes of the inverted U-tube(s) should be centrally located at the elevation of the most active part of the air stream.

MOUNTING

FLOOR STAND METHOD

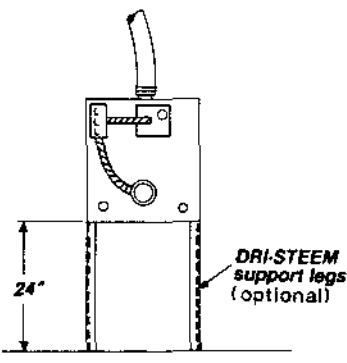

TRAPEZE HANGER METHOD

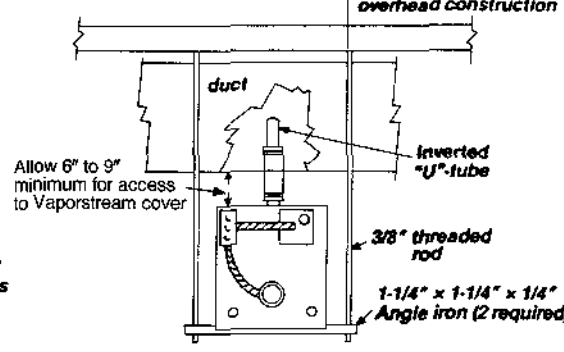

BRACKETED TO WALL METHOD

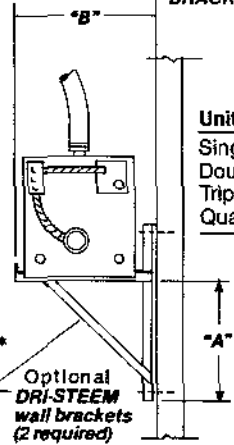

Unit	DIMENSIONS	
	"A"	"B"
Single heater	15"	13"
Double heater	19"	15 1/2"
Triple heater	21"	21"
Quad heater	40"	25"

MOUNTING UNIT ON UNDERSIDE OF DUCT

Maintain 6" to 9" clearance below duct to facilitate cover removal

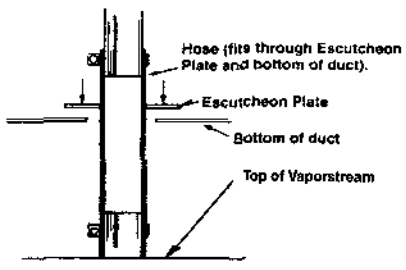
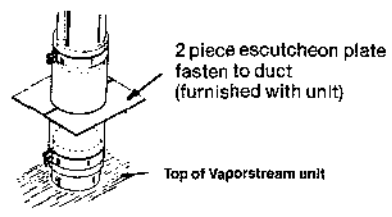

ADDITIONAL INVERTED U-TUBE MODEL

Improves absorption in 'tall' air streams.

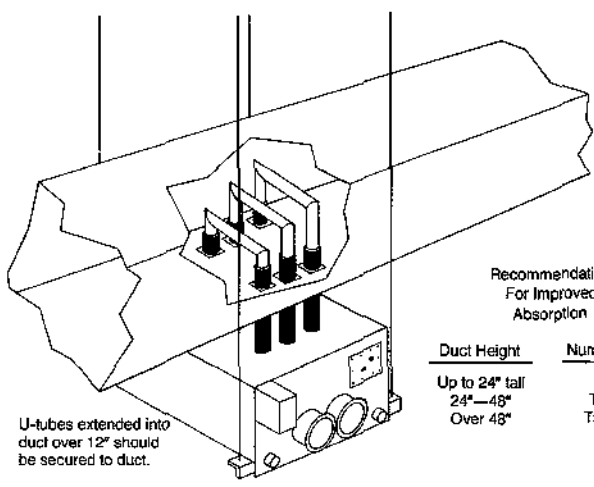

Recommendation For Improved Absorption

Duct Height	Number of Tubes
Up to 24" tall	One tube
24" - 48"	Two Tubes
Over 48"	Three Tubes

SINGLE INVERTED U-TUBE MODEL

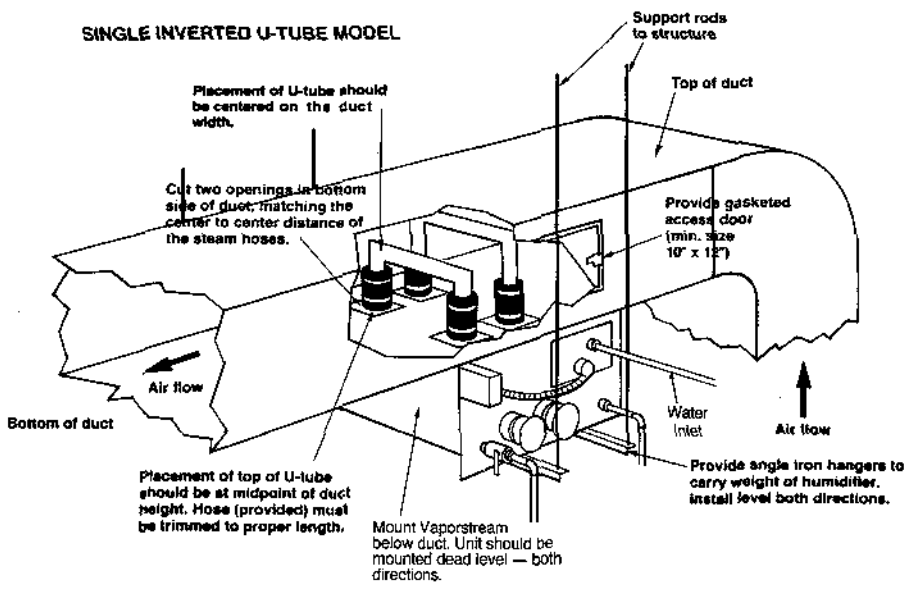

COMPONENTS AND PIPING METHOD

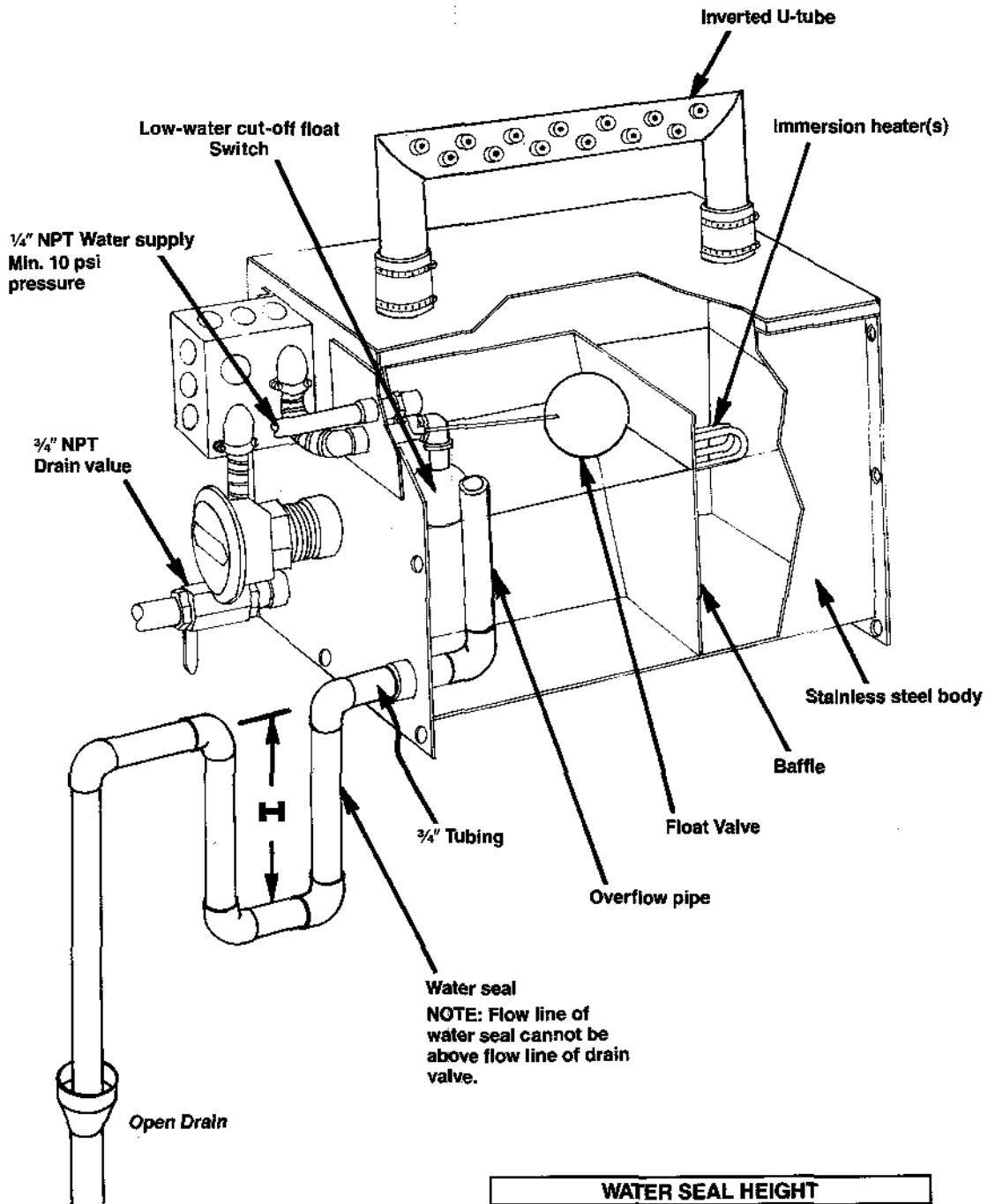

NOTE: Drain piping material must be suitable to handle 212°F (100°C) water.

WATER SEAL HEIGHT	
POUNDS/HOUR	H (INCHES)
5-50	5
51-94	7
95-138	10
139-183	14
184-227	18

Drain Piping

A drain line should be extended from the over-flow pipe connection to a sanitary waste. A water seal must be provided in the drain line of sufficient height to contain the pressure developed within the humidifier. Without this, steam will be forced through the drain line which could be objectionable. The depth of the water seal must be sufficient to overcome the static pressure of the air handling system plus the pressure developed by the humidifier itself. Consult table on page 11 for height of water seal.

Makeup Water Piping

Use cold or hot makeup water. If the water pressure is above 60 PSI and/or water hammer would be objectionable, a pressure reducing valve or shock arrester should be installed. Even though the Vaporstream has an internal 1" "air gap", some local codes may require a vacuum breaker.

Warning: Minimum water supply pressure 10 PSI

Steam Hose Piping

When the remote mounted steam hose method is used, the stainless steel dispersion tube and the connecting hose must be installed at a pitched level. Both the dispersion tube and the connecting hose should be pitched back to the humidifier. A 2" per foot of length drop is recommended. When this is not possible due to duct elevation or obstruction, alternate arrangements may be used. The following drawings illustrate the recommended hose connection methods to remove condensate build-up.

When obstruction prevents dispersion tube from being continuously pitched back to humidifier.

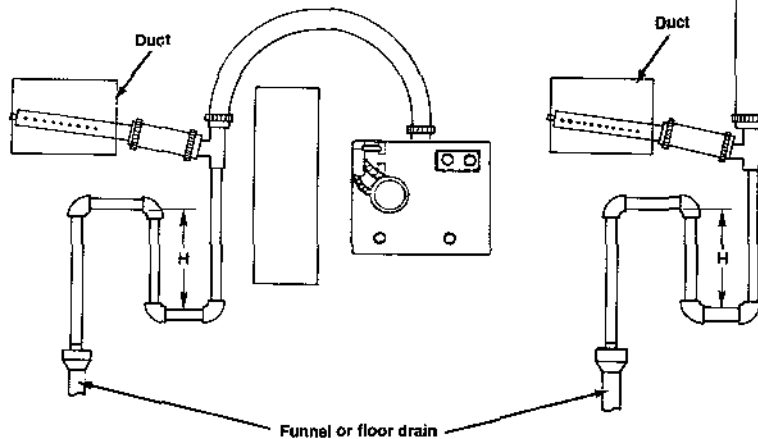

When humidifier must be mounted higher than the duct.

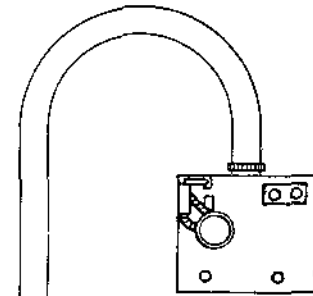

H = water seal height.
See chart on page 10.

DISPERSION TUBE AND HOSE KIT INSTALLATION WITH CONDENSATE LINES

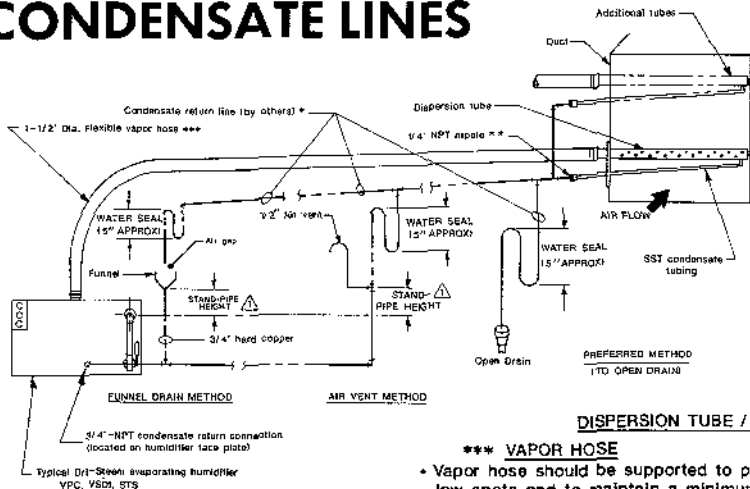

Flow Rate (Pounds/Hour)	Stand-Pipe Height (Inches)
5 - 50	5
51 - 94	7
95 - 138	10
139 - 183	14
184 - 227	18

HEIGHT REQUIRED TO OVERCOME HUMIDIFIER INTERNAL PRESSURE.

*NOTE: Return line piping material must be suitable for 212°F (100°C) water.

Minimum condensate return line size:
— One or two tubes - 1/2" I.D.
— Three or more tubes - 3/4" I.D.

** 3/8" DIA. CONDENSATE TUBING IS NOT NEEDED AND NOT PROVIDED WHEN STEAM FLOW IS 12 KW 13.44/HR OR LESS PER DISPERSION TUBE.

DISPERSION TUBE / HUMIDIFIER INTERCONNECTION VAPOR RIGID PIPING (WHEN USED)

*** VAPOR HOSE

- Vapor hose should be supported to prevent sags or low spots and to maintain a minimum pitch of 2" per foot back to the humidifier

BOTH METHODS

- Insulating the vapor hose or rigid piping will reduce the loss in output caused by condensation
- When mounting the humidifier above the level of dispersion tube, consult the appropriate operation and maintenance manual for details.

Failure to follow the above recommendation may result in excessive back pressures being imposed on the humidifier. This in turn may lead to dispersion tube(s) spitting, lost water seals or leaking gaskets. When distance between humidifier and the dispersion tube(s) exceeds 20 feet, consult factory for special recommendations.

TUBE MOUNTING

- Mount dispersion tube dead level.
- Best vapor absorption occurs when dispersion tube discharges against the air flow; specify right or left hand discharge (right hand shown).

VAPOR RIGID PIPING (WHEN USED)

- Vapor piping should have a minimum I.D. of 1.5 inches.
- A minimum pitch of 2" per foot back to the humidifier should be maintained
- 90° elbows are not recommended, use two 45° elbows one foot apart instead
- Thin wall tubing will heat up faster and cause less start up steam loss than heavy wall pipe.

INSTALLING THE VAPORSTREAM MODEL "D.I." UNIT

Location

When selecting the location, first consideration should be given to rapid, thorough absorption of the steam. The warmest air will most readily absorb the steam. The most active part of the air stream will provide the best mixing of the steam and air. Avoid dead spots such as the inside curve of an elbow or an area immediately downstream of a baffle plate. Since the "fog" will travel some distance before "disappearing" and will saturate objects it touches while visible, avoid discharging the steam closer than 8-10 feet upstream of fans, filter, dampers, etc. unless the air temperature is warmer than 90 degrees F. If so, 4-5 feet is permissible.

When the remote mounting method with the vapor hose kit is used, the dispersion tube holes should be pointed into the air stream and the tube and steam hose pitched properly. The condensate should drain back to the humidifier in the vapor hose or the condensate return hose. When obstructions prevent this, an alternate method is used (see page 11). Waterlogged low points in the vapor hose will cause "gurgling" and in severe conditions periodic "slugs" of condensate may be discharged into the duct.

The location selected must also provide for electrical service, cold water for makeup and sanitary waste.

Mounting

For proper operation of the water level controls the humidifier should be mounted dead level.

If the Vaporstream is to be installed above expensive materials or devices, a drain pan of sufficient size and depth to retain rapid or sudden drainage of the contents of the humidifier should be provided. The drain pan should be drained to a sanitary waste.

Electrical

The current characteristics, and capacity requirements should be checked against the nameplates. The control cabinet should be mounted in a location convenient for service. All wiring must be in accordance with all governing codes and the Vaporstream wiring diagram. The diagram is inside of the control cabinet. The wiring between the control cabinet and the humidifier must be 105 degrees C rated wire.

The basic water level system and low water protection circuit found on page 14 is common to all VSDI model Vaporstream humidifiers.

Caution: Only qualified electrical personnel should perform Installation and Startup Procedures.

STARTUP AND CHECKOUT PROCEDURES

1. Mounting

Check mounting to see that unit is level and securely supported before filling with water.

2. Piping

Verify that all piping connections have been completed as recommended and that water pressure is available.

3. Electrical

Verify that all wiring connections have been made in accordance with the Vaporstream wiring diagram.

4. Control Circuit

- a) Adjust humidistat to "call" setting.
- b) Open shut off valve on water supply line. Unit should begin filling through operated fill valve.
- c) Shortly before fill valve shuts off, the low water cutoff switch will "make". When this switch makes, the heating element contactor(s) will be actuated after a ten second delay. A time delay relay prevents contactor chatter due to bouncing of low water cutoff float.
- d) Check low water cutoff circuit
 1. Close manual stop valve on water supply.
 2. Open ball valve and start draining unit.
 3. When water level drops past switching level on the low water cutoff float, the heating element contactor(s) will drop out.
 4. When step 3 has been satisfactorily completed, close drain valve.
- e) Check out function of field installed safety controls such as fan proving switch etc. Contactor(s) should drop out when any proving switch is "open".
- f) Check heater draw by testing and recording voltage and amperage in each phase. Readings should match nameplate readings — nameplate is located on the humidifier housing.
- g) Inspect installation for leaks by operating the Vaporstream. Any steam or air leaks should be sealed.

5. Maintenance Recommendations

Assuming that the demineralizing equipment has supplied the Vaporstream with mineral free water, cleaning and flushing will not be needed.

At least annually however, the humidifier should be inspected for leaks. Also, the current draw of the heaters should be checked and all safety devices in the control circuit should be cycled on and off to verify that they are functioning.

VAPORSTREAM D.I. SINGLE HEATER CONTROL CABINET PARTS LIST

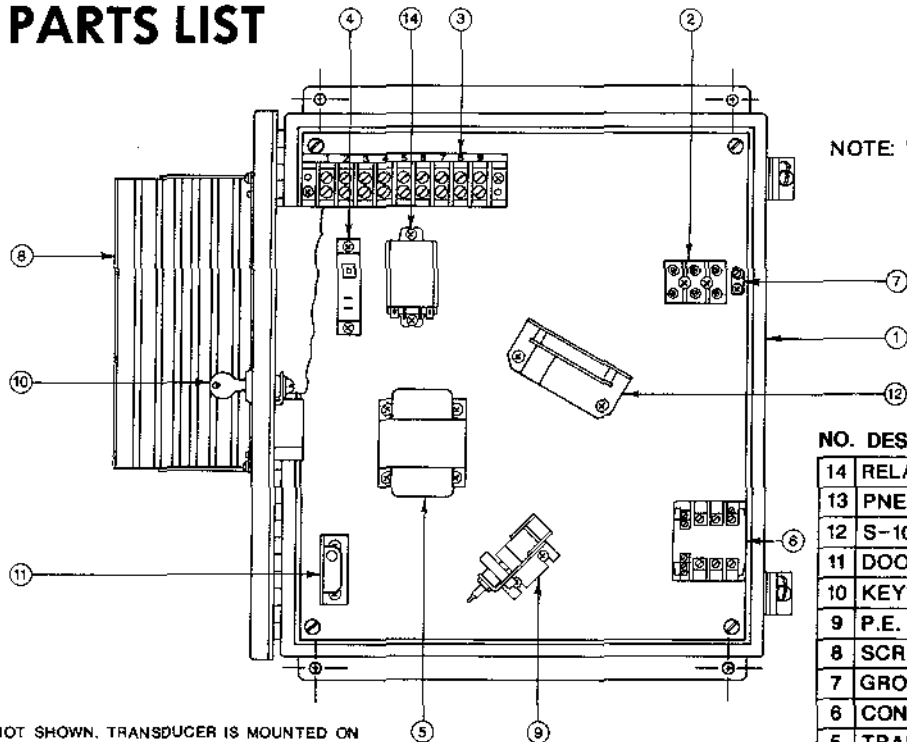

NOTE: WHEN ORDERING SPECIFY HUMIDIFIER MODEL AND SERIAL NUMBERS.

NO.	DESCRIPTION	PART NO.
14	RELAY	407900
13	PNEUMATIC TRANSDUCER	501490
12	S-10 TP MODULATOR BOARD	408680
11	DOOR INTERLOCK SWITCH	408470
10	KEYLOCK	407100-009
9	P.E. SWITCH	408100
8	SCR MASTER	
7	GROUND LUG	409250-017
6	CONTACTOR	407000
5	TRANSFORMER	
4	TIME DELAY RELAY	408440
3	TERMINAL STRIP	408250
2	POWER BLOCK	
1	CONTROL CABINET	

- NOT SHOWN. TRANSDUCER IS MOUNTED ON CONTROL CABINET DOOR EXTERIOR AT SCR LOCATION.
- SPECIFY COMPONENT PART NUMBER WHEN ORDERING.
- OPTIONAL
- VARIES WITH SPECIFIC ORDER.

VAPORSTREAM D.I. MULTIPLE HEATER CONTROL CABINET PARTS LIST

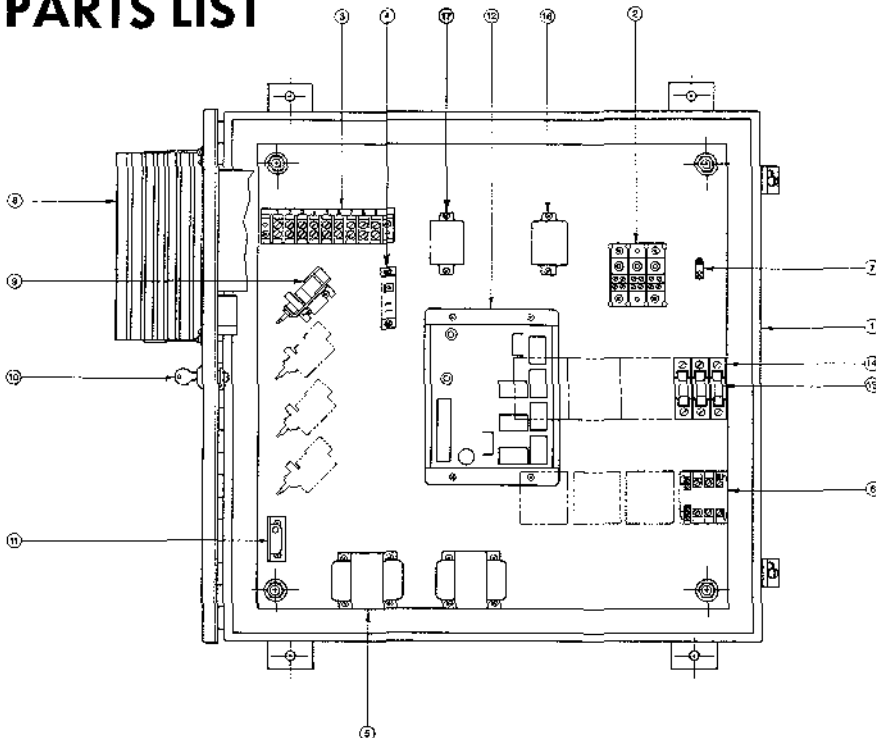

NOTE: WHEN ORDERING SPECIFY HUMIDIFIER MODEL AND SERIAL NUMBERS.

NO.	DESCRIPTION	PART NO.
17	RELAY	407900
16	RELAY	407900
15	FUSES	
14	FUSE BLOCK	408750
13	PNEUMATIC TRANSDUCER	501490
12	SEQUENCER	
11	DOOR INTERLOCK SWITCH	408470
10	KEYLOCK	407100-009
9	P.E. SWITCH	408100
8	SCR SLAVE	
7	GROUND LUG	409250
6	CONTACTOR	407000
5	TRANSFORMER	
4	TIME DELAY RELAY	408440
3	TERMINAL STRIP	408250
2	POWER BLOCK	
1	CONTROL CABINET	

- NOT SHOWN. TRANSDUCER IS MOUNTED ON CONTROL CABINET DOOR EXTERIOR AT SCR LOCATION.
- SPECIFY COMPONENT PART NUMBER WHEN ORDERING.
- OPTIONAL
- VARIES WITH SPECIFIC ORDER.
- SPECIFY S-25, S-11, S-8, OR OC-833A
- SUPPLIED WITH SOME OPTIONS AND HIGH CURRENT OUTPUT CONDITIONS.
- TWO SUPPLIED WHEN CONTROL LOAD EXCEEDS RATING OF ONE TRANSFORMER.

COMPONENTS PARTS LIST

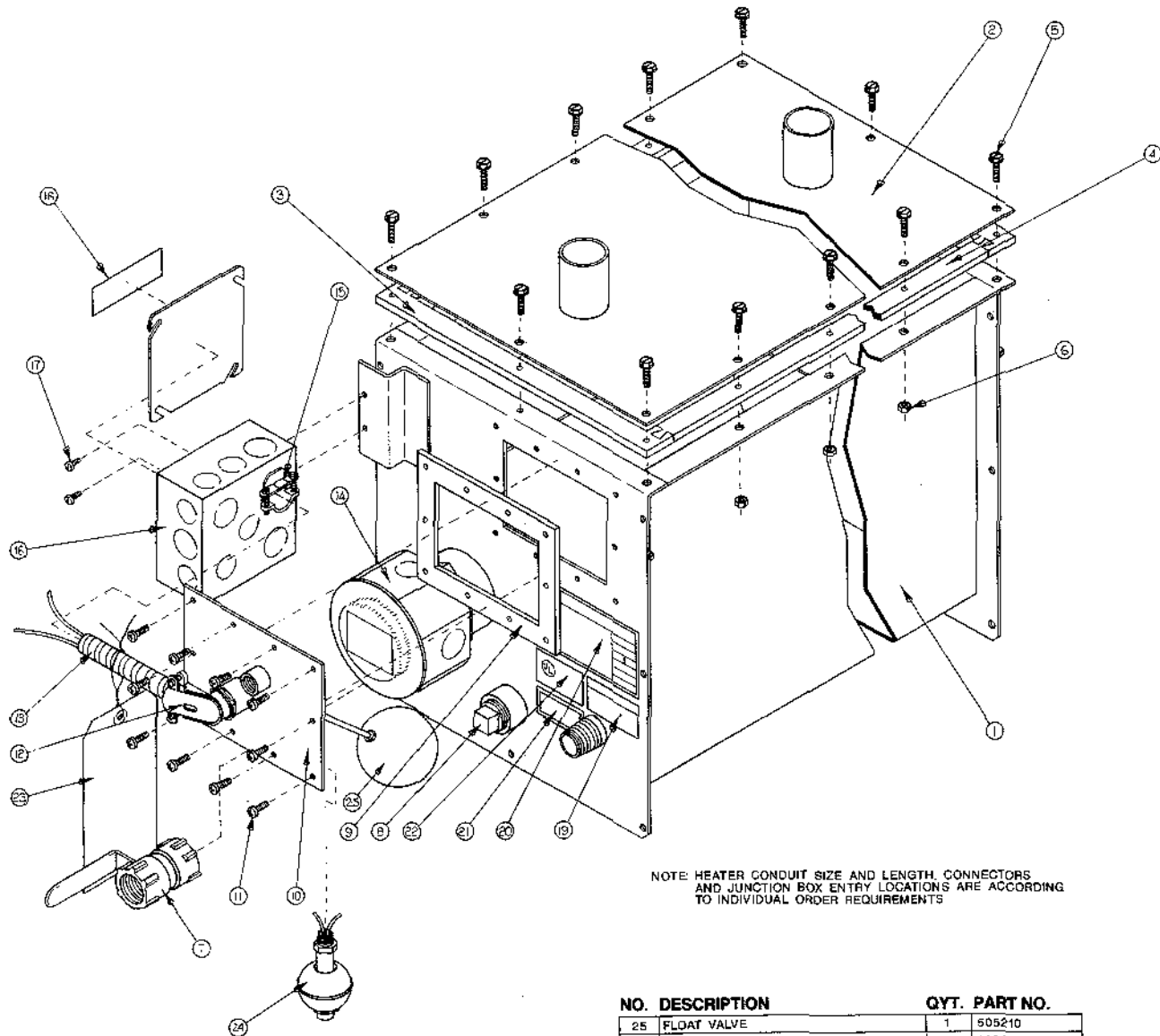

NOTE: HEATER CONDUIT SIZE AND LENGTH, CONNECTORS AND JUNCTION BOX ENTRY LOCATIONS ARE ACCORDING TO INDIVIDUAL ORDER REQUIREMENTS

- ⚠ ON UL APPROVED UNITS ONLY
- ⚠ NOT INCLUDED ON UNITS WITHOUT CONTROL CABINET
- ⚠ FOR SPECIFIC TYPE, SIZE, AND/OR QUANTITY REFER TO PARTICULAR ORDER REQUIREMENTS
- ⚠ USE HONEYWELL LABEL ON HONEYWELL ORDERS. FILE NO. E67513
- ⚠ NOT INCLUDED ON UNITS WITH CONTROL CABINET MOUNTED
- ⚠ LENGTH VARIES PER INDIVIDUAL ORDER

NO.	DESCRIPTION	QTY.	PART NO.
25	FLOAT VALVE	1	505210
24	LOW WATER CUT-OFF SWITCH	1	408420
23	WATER SEAL TAG	1	805210
22	UL LABEL	1	805100
21	HUMIDIFIER-CONTROL CABINET LABEL	1	805000-005
20	HUMIDIFIER LABEL	1	805240
19	CAUTION LABEL	1	805150
18	CONTROL VOLTAGE LABEL	1	⚠
17	8-32 x 3/8" PH SCREW	2	700000-005
16	PULL BOX AND COVER	1	⚠
15	3/8" STRAIGHT BOX CONNECTOR	1	407125-001
14	IMMERSION HEATER	1	⚠
13	3/8" HWS FLEXIBLE CONDUIT	1	407110-002
12	3/8" 90° BOX CONNECTOR	1	407120-001
11	10-32 x 1/2" SST REC SCREW	10	700050-001
10	FLOAT PLATE	1	165700
9	FLOAT PLATE GASKET	1	308280
8	3/4" NPT BLACK PLUG	1	201200-015
7	3/4" SST BALL VALVE	1	505000
6	10-32 HEX NUT	⚠	700000-002
5	10-32 x 3/4" HEX HD SCREW	⚠	700000-007
4	COVER GASKET (SIDE)	2	308400
3	COVER GASKET (END)	2	308300
2	COVER	1	⚠
1	TANK WELDMENT	1	⚠

Shown below is a typical wiring schematic for the Control Cabinet.

Please refer to the diagram furnished with the humidifier for specific questions concerning the unit being installed.

VAPORSTREAM HUMIDIFIER WIRING DIAGRAM

3Φ 1 HEATER
1 STAGE

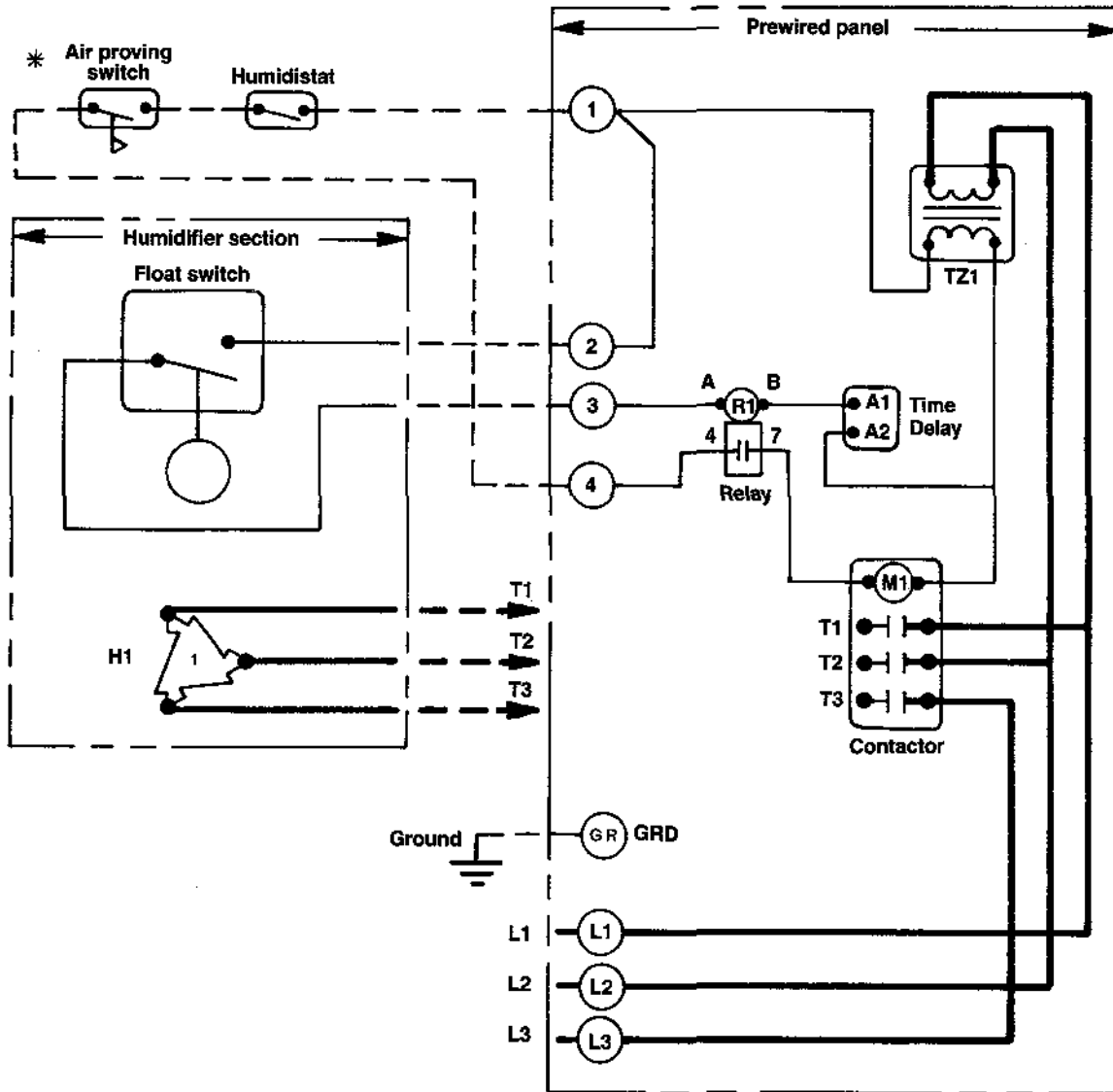

LEGEND

- * OPTIONAL
- POWER WIRING
- CONTROL CIRCUIT WIRING
- - - - FIELD WIRING

NOTE:

ALL WIRING PER NATIONAL AND LOCAL ELECTRICAL CODES

DIAGRAM NO.

CURRENT DRAW
_____ UNIT AMPS _____ PER HEATER AMPS

PRIMARY VOLTAGE _____ CONTROL VOLTAGE _____

MODEL NO. _____ JOB _____ ORDER NO. _____

MAINTENANCE SERVICE RECORD

DATE INSPECTED	PERSONNEL	OBSERVATION	ACTIONS PERFORMED

The Dri-Steem Warranty

- Warranty.** Dri-Steem Humidifier Company (the "Company") guarantees its products to be free of defects in materials and workmanship under the service for which they are intended. The Company will repair or replace—without charge except for labor charges—products or parts which are found to be defective within one year from the date of shipment or, at the option of the Company, will refund the purchase price.
- Exclusion of other warranties.** The warranty described in the previous paragraph shall be IN LIEU OF any other warranty, express or implied, including but not limited to any implied warranty of MERCHANTABILITY or fitness for a particular purpose.
- Limitation of Remedies.** By purchasing the Company's products, the purchaser agrees with the Company that the purchaser's sole and exclusive remedy shall be for the repair or replacement of defective parts or products, without charge except for labor charges, as described in paragraph 1. The purchaser agrees that no other remedy (including, but not limited to, incidental or consequential damages for lost profits, lost sales, injury to person or property, or any other incidental or consequential loss) shall be available to him.

DRI-STEEM HUMIDIFIER COMPANY
BOX 128, 11300 WEST 47TH STREET
HOPKINS, MINNESOTA 55343
TELEPHONE 1-800-328-4447
In MN, call (612) 935-6986
TELEX: 290675
FAX: (612) 935-4831