

READ AND SAVE THESE INSTRUCTIONS

VAPORMIST[®] and VAPORMIST[®] D.I. ELECTRIC STEAM HUMIDIFIERS

For Ducted or Ductless Applications

Installation Instructions
and
Maintenance Operations
Manual

CSA & UL LISTED

DRI STEEM[®]
HUMIDIFIER COMPANY

TABLE OF CONTENTS

TO THE PURCHASER AND INSTALLER

We have done our best to provide a product that will give many years of satisfactory service. Spend a few moments to familiarize yourself with these installation and maintenance instructions. Doing so may prove to pay big dividends in the form of better performance and easier maintenance in the years to come.

DRI-STEEM Humidifier Company

Installation	4-5
Piping	6
Electrical	6-7
Mechanical/Electrical Specification	8
SDU	9-10
Operation	11-12
Maintenance Procedure	13-14
Replacement Parts	15-19
Maintenance Service Record	20
Warranty	20

VAPORMIST DIAGRAMS

VAPORMIST Humidifier

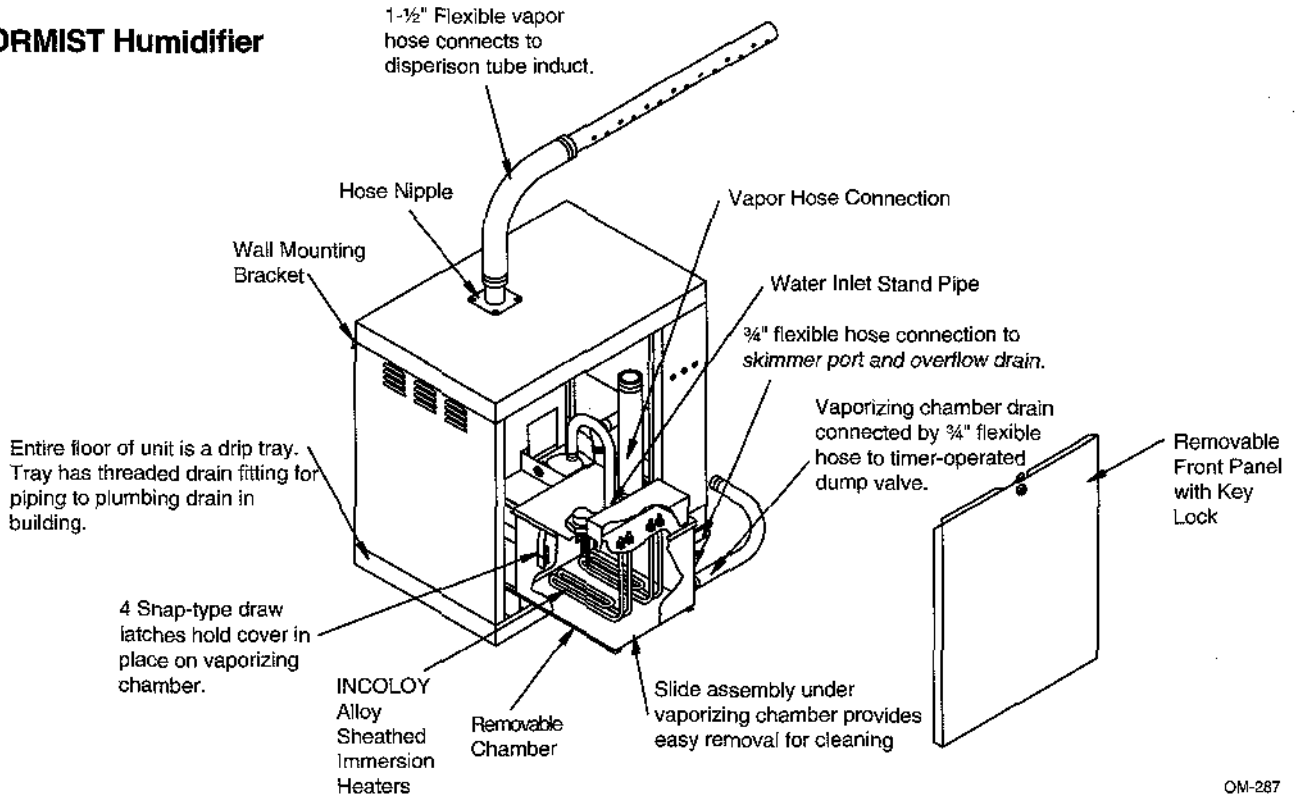

VAPORMIST DI Humidifier (Deionized Water)

Standard VAPORMIST units require water conductivity of 100 micromhos/centimeter (2 grains per gallon) to operate. They will not operate with water treated by reverse osmosis or deionization processes. The VAPORMIST DI humidifier shown here is specifically designed for use with deionized or reverse osmosis water.

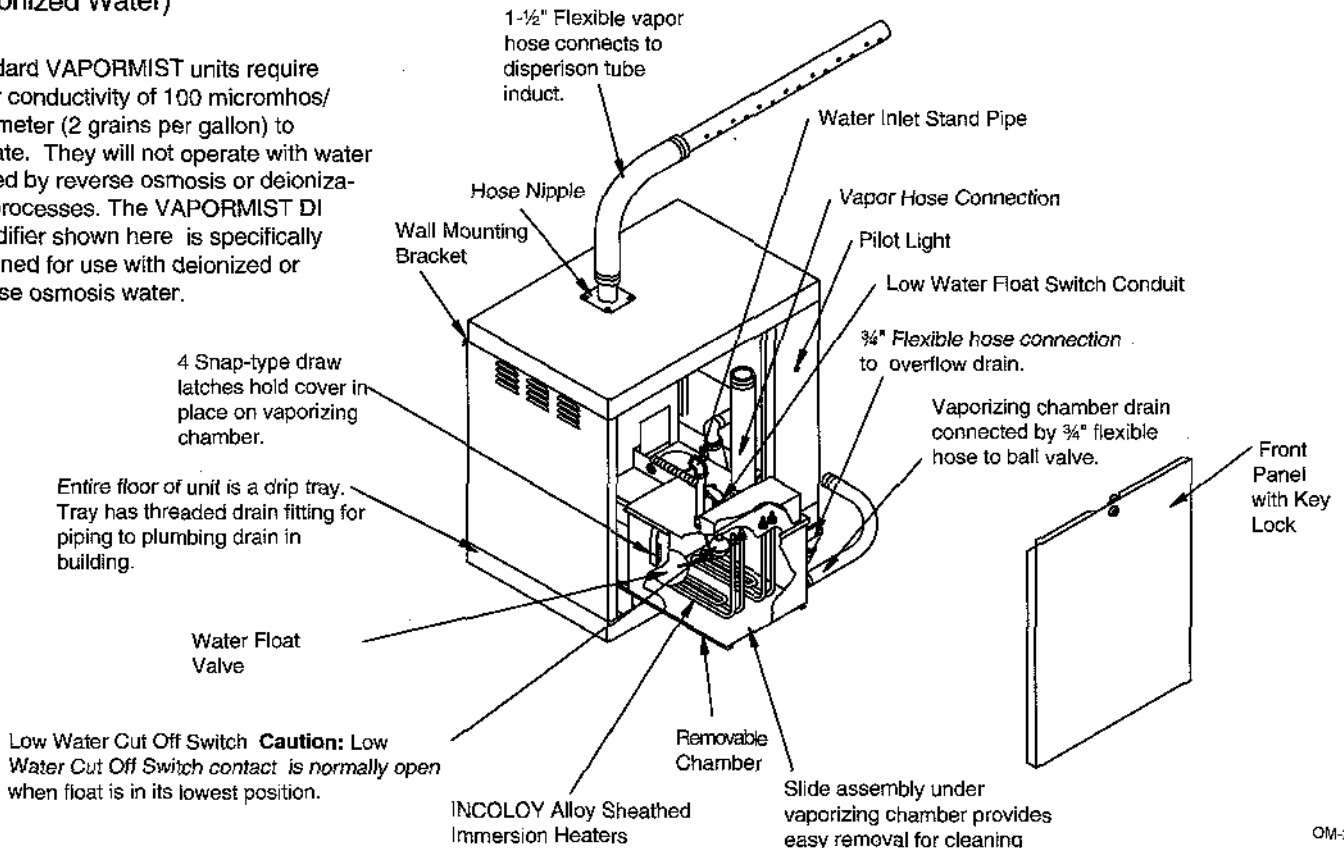

INSTALLATION

Selecting the Location

The VAPORMIST is an attractive cabinet unit intended for installation in mechanical rooms or spaces located near air duct systems. This unit is designed for wall hanging.

When mounting on a stud wall, (studs 16" on center), locate studs and position mounting bracket in place so the two 16" holes will center on a stud. Mark hole location and pre-drill 1/4" diameter pilot holes. Secure bracket to wall with provided lag bolts.

For hollow block or poured concrete wall mounting, position mounting bracket in place and mark the second hole from each end. Drill appropriate pilot hole for two 3/8" toggle bolt or two 3/8" machine bolt lead anchors. Secure bracket in place using selected method.

Use the following as considerations for selecting the location of the humidifier:

- visible location (preferred)
- convenient access to duct
- electrical and plumbing connections
- required clearances

A mounting location should be selected that provides a minimum clearance of 36" to the front and 24" to the right side of the unit. This clearance is required for removal of the vaporizing chamber and access to electrical compartment.

Electrical power supply, water make-up piping and drain piping must also be considered. These service connections are made at the lower right rear corner of the unit. If drainage by gravity is not possible, a small lift pump should be considered.

Piping and Wiring

Water make-up piping may be of any code-approved material (copper, steel, or plastic). The final connection size is 1/4" NPT.

In cases where water hammer may be a possibility, a shock arrestor should be considered.

Drain piping may be of any code approved material (copper, steel, or plastic rated for 212° F minimum). The final

connection sizes are 3/4" O.D. for evaporator drain and 1/2" NPT for cabinet drain. These connection sizes should not be reduced in size. See Figures 6.1 and 6.2 for proper drain piping configurations. The evaporator drain and cabinet drain should be piped separately to and dump into a floor drain. Combining the two into a single drain line often results in the backflow of drain water into the humidifier cabinet leading to malfunctioning of the unit.

VAPORMIST is designed for a single source electrical power supply. Refer to the wiring diagram for wire sizes. The wiring diagram is located inside the removable panel on the right hand side of the unit and a generic diagram on pages 6 and 7 of this manual.

When the VAPORMIST humidifier is in final operation panel access keys should be removed and secured in a different place.

Examples of Installation In A Duct

Figure 1

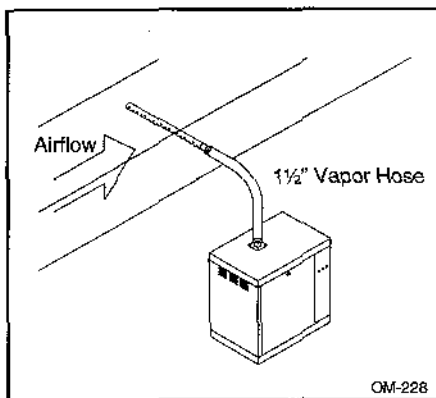

Horizontal mounting of dispersion tube in a duct, connected via vapor hose to a wall mounted VAPORMIST unit.

NOTE: Vapor hose and dispersion tube should be pitched back to the humidifier with a gradual slope of 2" per foot (minimum).

Figure 2

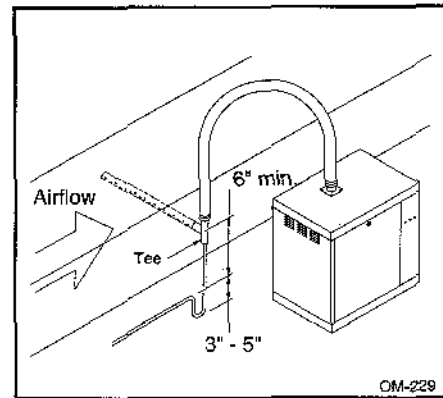

Horizontal mounting of dispersion tube in a duct that is located lower than the VAPORMIST unit. A water seal must be located in drain line as shown to maintain steam pressure.

Figure 3

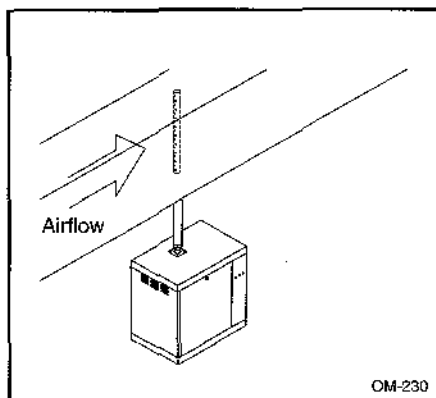

OPTIONAL: The dispersion tube can be mounted vertically in the duct. Not recommended on VM-16

NOTE: When duct is located more than 20 feet away from unit, vapor hose is not recommended. 1 1/2" minimum I.D. hard pipe should be used in these applications.

INSTALLATION

VAPORMIST Dispersion Tube with Condensate Drain Line

Tube Mounting

- Mount dispersion tube dead level.
- Best vapor absorption occurs when dispersion tube discharges against the air flow.

Dispersion Tube/Humidifier Interconnection

* Vapor Hose

- Vapor piping should have a minimum I.D. of 1.5 inches.
- A minimum pitch of 2" per foot back to the humidifier should be maintained.
- 90° elbows are not recommended, use two 45° elbows one foot apart instead.
- Thin wall tubing will heat up faster and cause less start up steam loss than heavy wall pipe.

Both Methods

- Insulating the rigid piping will reduce the loss in output caused by condensation
- When mounting the humidifier above the level of dispersion tube, see Figure 2 on page 4.

Failure to follow the above recommendation may result in excessive back pressures being imposed on the humidifier. This in turn may lead to dispersion tube(s) spitting, lost water seals or leaking gaskets. When distances between humidifier and the dispersion tube(s) exceed 20 feet, consult factory for special recommendations.

Installation to Open Drain

****Note:** Return line piping material must be suitable for 212°F (100°C) water.

Minimum condensate return line sizing:

- One or Two tubes - 1/2" I.D.
- Three or more tubes - 3/4" I.D.

*** 1/2" diameter condensate tubing is not needed and not provided when steam flow is 12KW (34 lbs/hr.) or less per dispersion tube.

Single Tube

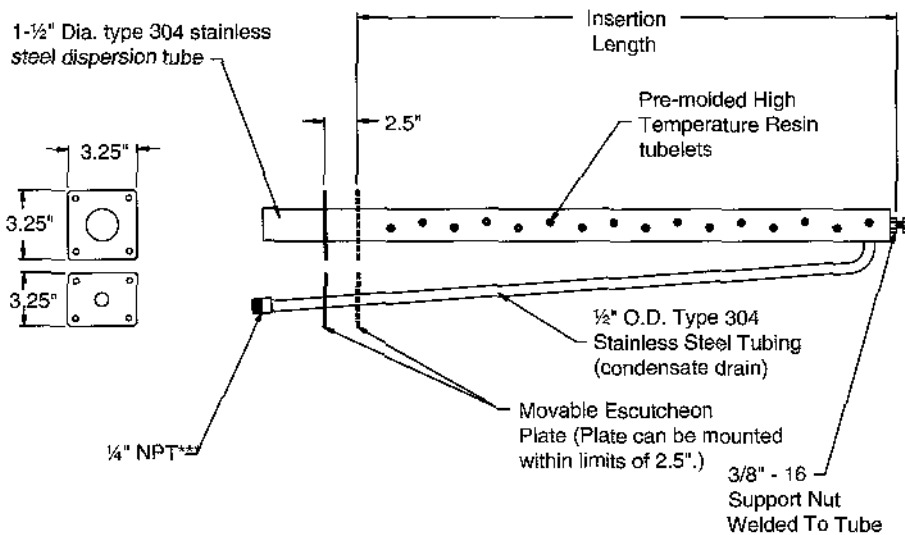

OM-1

Multiple Tube with Condensate Wasted to Floor Drain

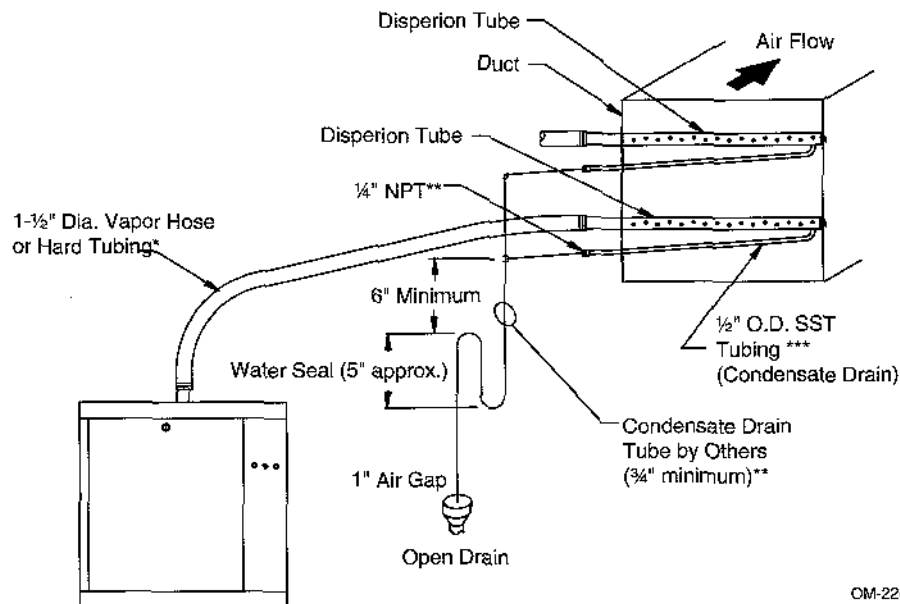

OM-224

PIPING/ELECTRICAL

Drain Piping Configurations

Figure 6.1 - Drain Adjacent to Wall

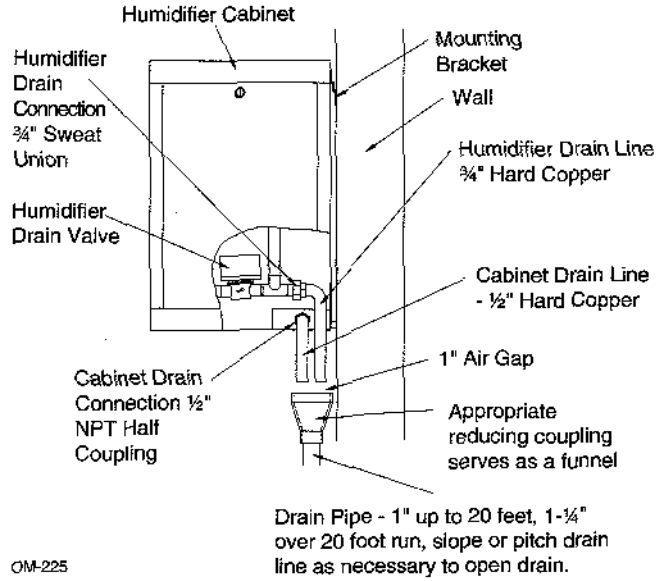

OM-225

Figure 6.2 - Drain Through or In Wall

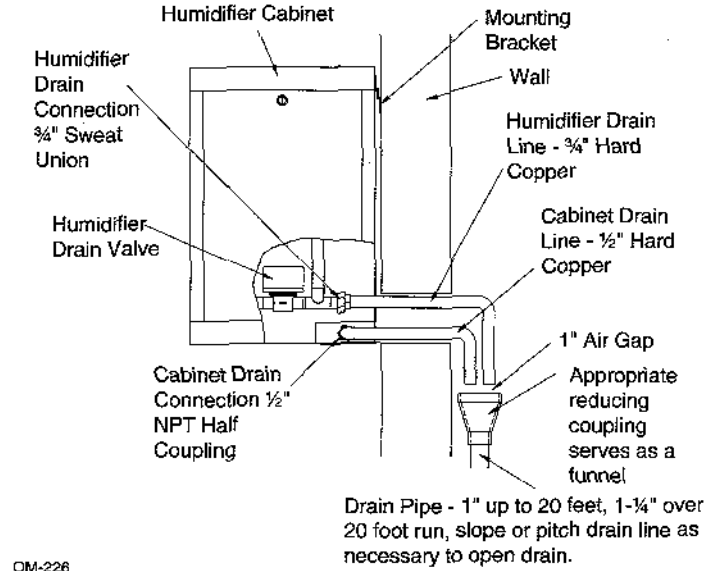

OM-226

VAPORMIST Wiring Diagram - With LW 415 (Auto Drain/Flush)

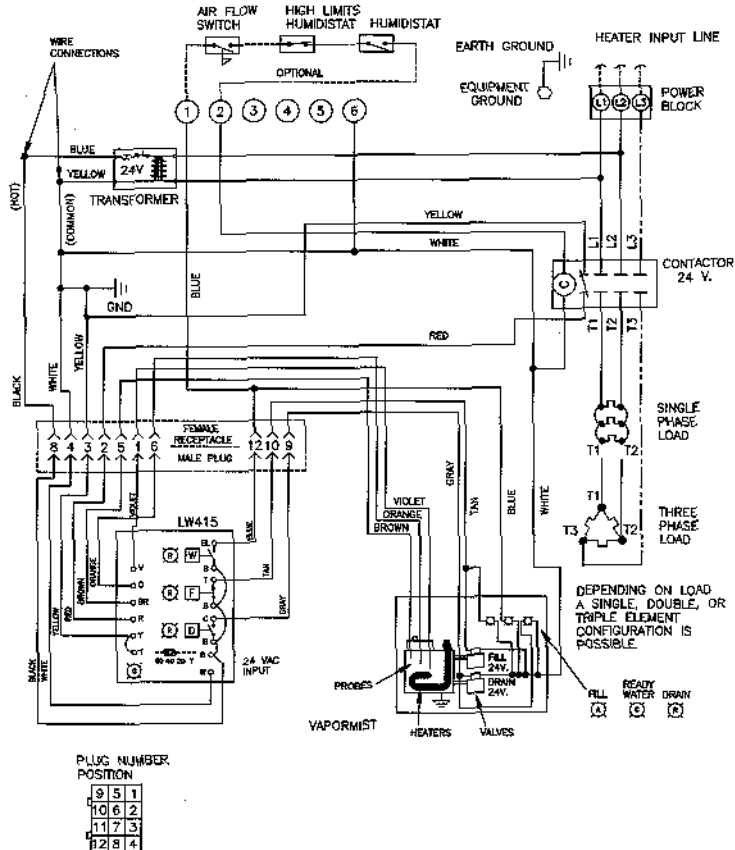

1. Equipment ground and all wiring to be per local and national electrical codes.
2. Input line _____ volts _____ phase for heater(s) circuit: operates on 50/60 hertz.
3. For wiring sizing, heater circuit line amps:
L1: _____ L2: _____
L3: _____
Recommended line fusing: _____ amps
4. Light emitting diode "on" during drain cycle.
5. Jumper pin connector selects timer/drain down cycle 20 hrs., T(test .5 hrs), 40 hrs., 80 hrs.
6. Drain duration of ten minutes.
7. Light emitting diode "on" in ready water condition.
8. Light emitting diode "on" when tank is full.
9. Green light emitting diode "on" when power is present at board.

OM-227

ELECTRICAL

VAPORMIST DI Wiring Diagram

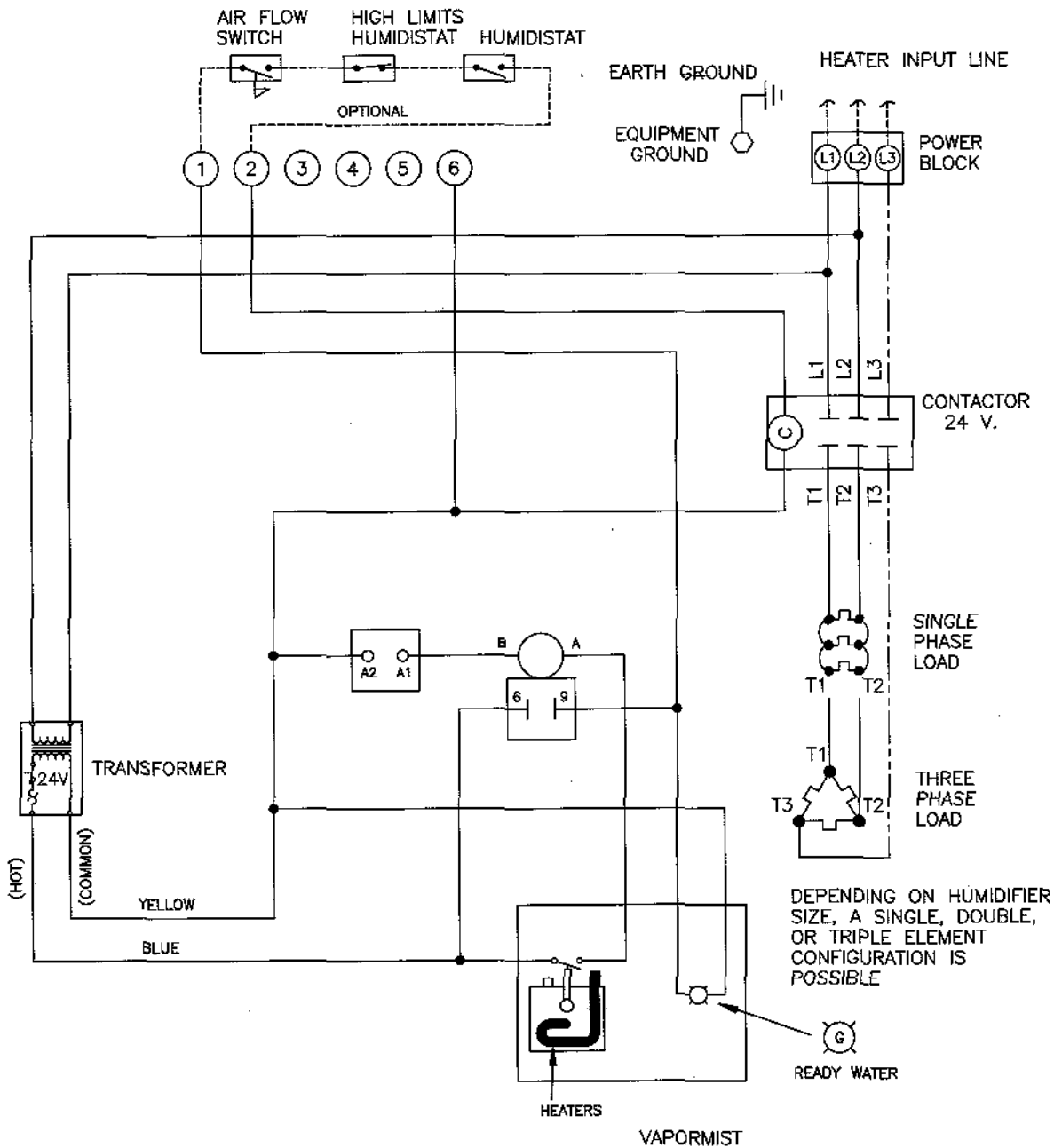

DEPENDENT ON HUMIDIFIER SIZE, A SINGLE, DOUBLE, OR TRIPLE ELEMENT CONFIGURATION IS POSSIBLE

1. Equipment ground and all wiring to be per local and national electrical codes.
2. Delay time on reley set for 15-20 seconds.
3. Input line _____ volts _____ phase for heater(s) circuit: operates on 50/60 hertz.
4. For wiring sizing, heater circuit line amps:
 L1: _____ L2: _____
 L3: _____
 Recommended line fusing: _____ amps

OM-233

MECHANICAL/ELECTRICAL SPECIFICATIONS

VAPORMIST Unit Dimensions

All measurements shown in inches.

Note: For VM 16 only, dispersion tubes will be equipped with a condensate tube when a hose kit is used. See page 5 for installation details.

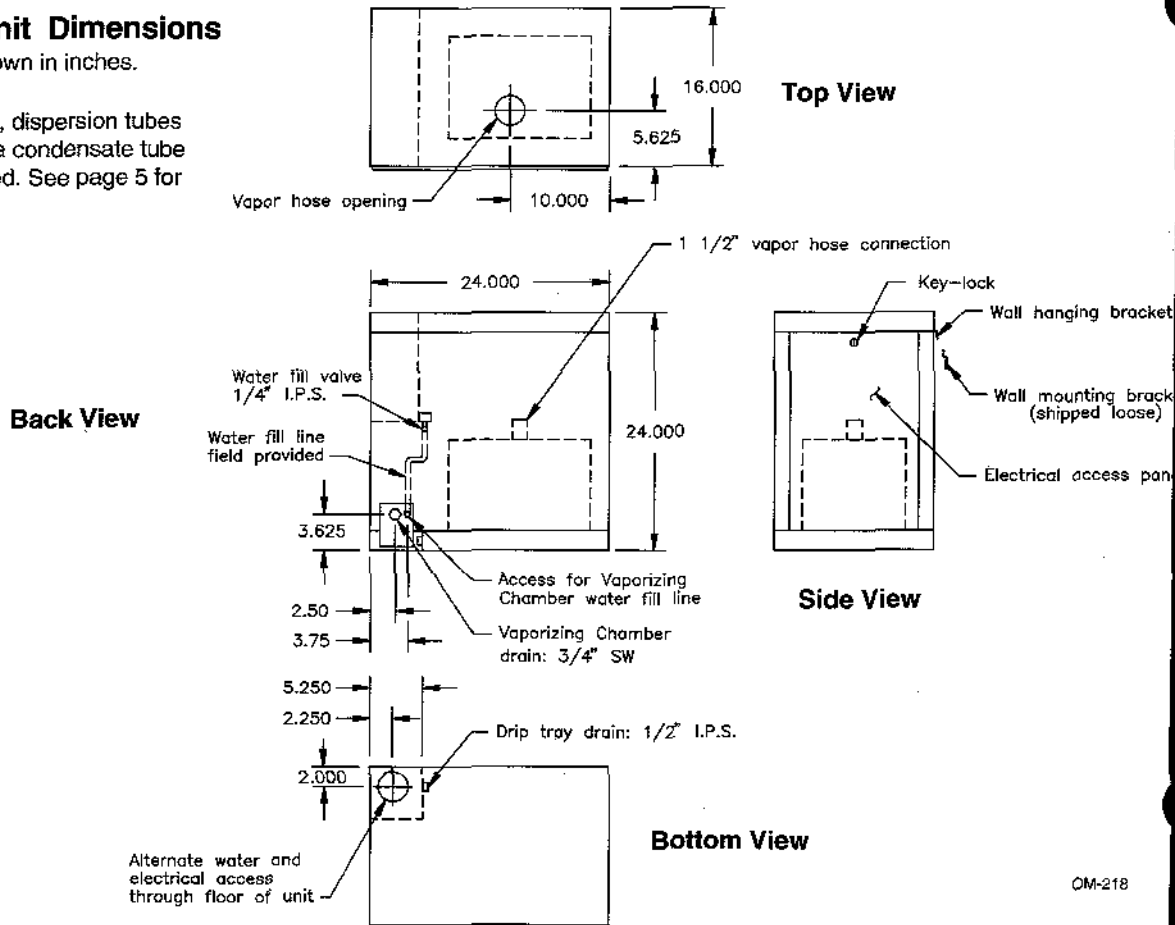

OM-218

Table 8-1: Electrical Specifications

	VM2		VM4		VM6		VM8		VM10		VM12		VM16*		
Op. Weight	83 lb.	38 kg	83 lb.	38 kg	93 lb.	42 kg	93 lb.	42 kg	93 lb.	42 kg	100 lb.	45.4 kg	100 lb.	45.4 kg	
Shp. Weight	78 lb.	35 kg	78 lb.	35 kg	85 lb.	39 kg	85 lbs.	39 kg	85 lb.	39 kg	92 lb.	41.7 kg	92 lb.	41.7 kg	
AMPS: 120/1	17.0	-	-	-	-	-	-	-	-	-	-	-	-	-	
*208/1/3 wire	9.6	19.2	28.8	38.5	-	-	-	-	-	-	-	-	-	-	
*240/1/3 wire	8.3	16.7	25.0	33.3	41.7	-	-	-	-	-	-	-	-	-	
480/1	4.2	8.3	12.5	16.7	20.8	25.0	33.3	44.4	38.5	19.2	14.4	12.7**	14.4	19.2	
208/3/4 wire	-	16.7**	25.0**	33.3**	29.2**	33.3	44.4	38.5	19.2	14.4	12.7**	14.4	19.2	25.0	
240/3/4 wire	-	14.4**	21.7**	28.9**	25.3**	28.9	38.5	33.3	44.4	38.5	19.2	14.4	12.7**	25.0	
480/3	-	7.2**	10.8**	14.4**	12.7**	14.4	19.2	25.0	33.3	44.4	38.5	19.2	14.4	12.7**	
KW	2	4	6	8	10	12	16	20	25	30	36	45	50	64	
Output/hour lb/gal/kg	6/7/2.7	12/1.4/5.4	18/2.2/8.2	24/2.9/10.9	30/3.6/13.6	36/4.4/16.4	50/6/22.7	60/7.2/27.3	75/8.9/34.1	90/10.6/41.7	108/12.8/50.3	126/15.0/59.0	150/18.8/72.6	180/22.5/88.3	216/27.0/104.1

* On 208/240 single phase (3 wire) and 3 phase (4 wire) supplies, the neutral line may be utilized for 120 volt when used in conjunction with SDU fan unit.

** For wire sizing. Highest leg draw is shown due to current unbalance in some cases. All VAPORMISTS operate 50/60 Hz.

AREA-TYPE APPLICATION USING SPACE DISTRIBUTION UNIT (SDU)

This optional fan unit mounts on top of the VAPORMIST cabinet.

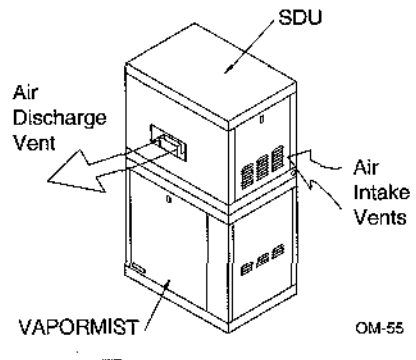

If necessary, fan unit can be wall mounted and VAPORMIST remotely located.

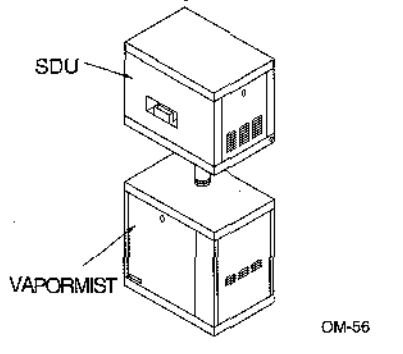

The space distribution unit (SDU) converts a VAPORMIST duct humidifier into an area-type humidifier. Instead of the steam dispersion tube being located inside an air duct, the dispersion tube is built into the fan unit. A fan draws in room air and blows it across the dispersion tube, where it picks up the moisture and disperses it into the room.

The space distribution unit can be used on all models, however a condensate drain from the dispersion tube is required in all applications. See page mechanical detail at bottom of this page.

Mounting the SDU

The SDU may be placed directly on top of the VAPORMIST cabinet or it may be mounted on a wall. A wall mounting bracket and two 3/8" lag bolts are provided with each fan unit.

For a stud wall mounting (16" on center

studs), locate studs and position mounting bracket in place so the two 16" holes will center on a stud. Mark hole location and pre-drill 1/4" diameter pilot holes. Secure bracket to wall with provided lag bolts.

When mounting the SDU on hollow block or poured concrete walls, position mounting bracket in place and mark the second hole from each end. Drill appropriate pilot hole for two 3/8" toggle bolts or two 3/8" machine bolt lead anchors. Secure bracket in place using selected method.

The following operational characteristic of area-type steam humidifiers should be considered when locating the humidifier for mounting: as steam is discharged from the humidifier, it quickly cools and turns to visible, warm, microscopic drops of water "fog" which are lighter than air. As this "fog" is carried away from the

humidifier by the fan air stream it tends to rise towards the ceiling. If this fog contacts solid surface (columns, beams, ceiling, pipes, etc.) before it disappears, it may collect and drip as water.

The distance the "fog" is blown and rises before it disappears is affected as follows:

The greater the space relative humidity, the higher and further the fog will carry and rise in the space before disappearing.

Table 9-1 states the minimum recommended vertical (RISE) and horizontal (CARRY) clearances for area-type humidifiers at space relative humidities.

The Space Distribution Unit (SDU) contains a 435 cfm blower (120/1/60) which is wired independently of the VAPORMIST humidifier.

On a call for humidity the humidifier will begin producing steam and the start relay will energize the SDU blower. When the steam reaches the SDU, a temperature sensing fan switch (located on the dispersion manifold) will close for secondary lock-on of blower. The humidifier will continue to produce steam until humidistat becomes satisfied, shutting off humidifier and de-energizing start-relay. The blower will continue to run until steam production ceases at which time the temperature switch will cool, open and stop the blower.

When SDU is in final operation, panel access keys should be removed and secured in a different place.

Table 9-1: SDU Visible Fog Travel

Humidifier Size	50% R.H.		60% R.H.	
	Rise (ft.)*	Carry (ft.)*	Rise (ft.)*	Carry (ft.)*
VM4	1.0	3.0	1.0	3.5
VM6	1.0	3.5	1.5	3.5
VM8	1.5	5.0	2.0	5.0
VM10	1.5	6.0	2.0	6.0
VM12	2.0	7.0	2.0	8.0
VM16	2.0	8.0	2.0	8.5

* Rise: Height visible fog rises above discharge grille of humidifier.
 Carry: Horizontal distance visible fog travels from humidifier.
 Surfaces cooler than ambient or objects directly in the path of visible fog discharge may cause condensation and dripping.

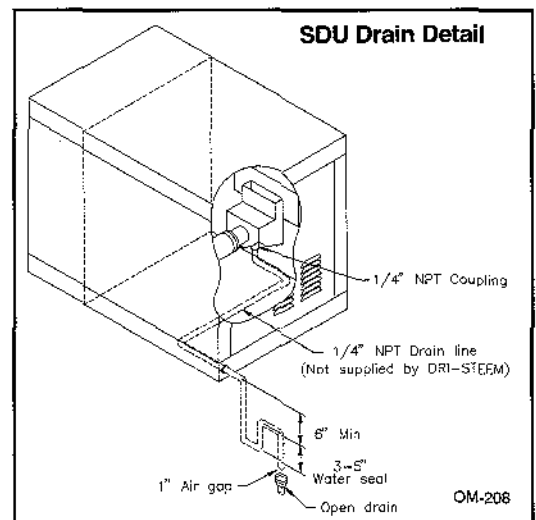
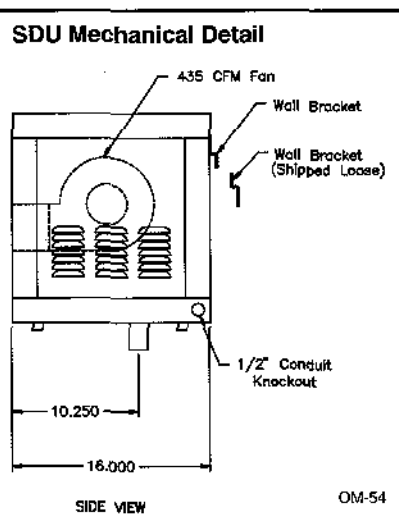

SDU ELECTRICAL

SUPPLY VOLTAGE 120 VOLTS, 1 PHASE, 50/60 HZ

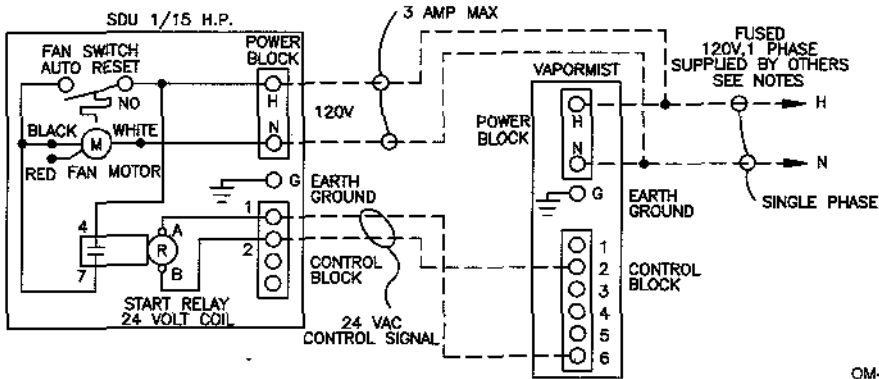

OM-220

SUPPLY VOLTAGE 208/240 SINGLE OR THREE PHASE, 50/60 HZ
(SINGLE PHASE 3 WIRE WITH GROUND OR THREE PHASE 4 WIRE WITH GROUND)

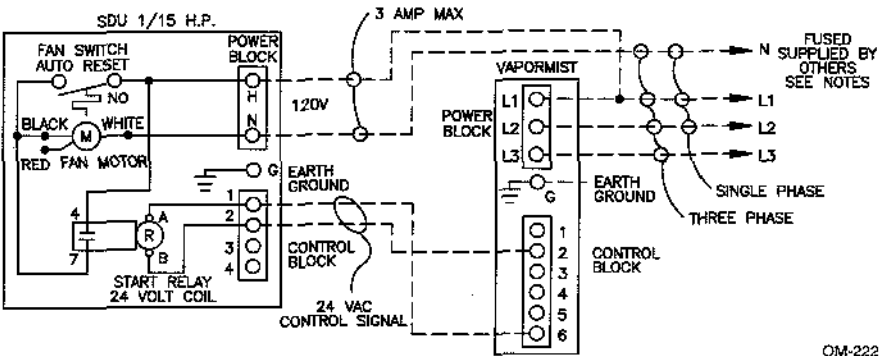

OM-222

SUPPLY VOLTAGE 480/575 SINGLE OR THREE PHASE, 50/60 HZ

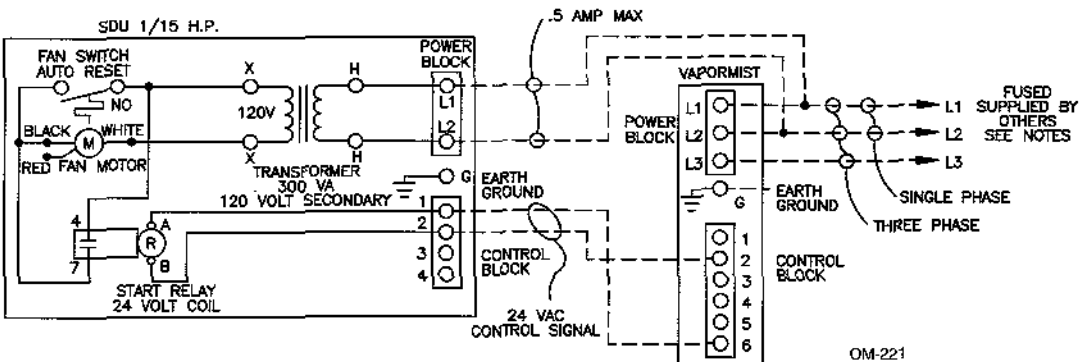

OM-221

DETAIL OF TRANSFORMER

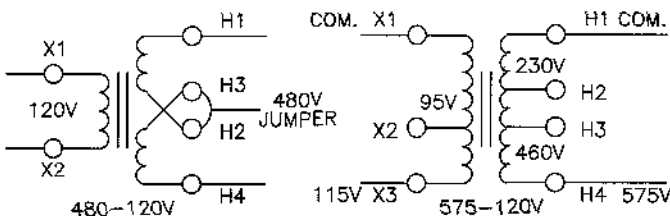

OM-223

OPERATION

Reliable, Electronic Probe Control
Maintains Water Level (Standard
VAPORMIST)

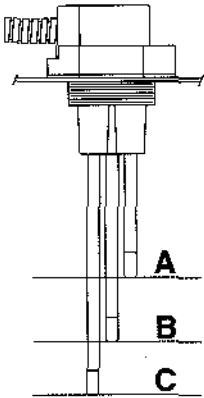

A simple 3-probe conductivity sensor cycles a solenoid operated water fill valve to maintain the proper water levels.

LW400 (Units shipped before 12/89.)
(Contact factory for wiring diagrams.)

Initial Start-Up

When power is first turned on, the solenoid operated water fill valve opens and begins filling the vaporizing chamber. Filling will continue until water reaches level "A", the fill valve closes. To ensure that a water seal is created in the overflow hose, disconnect probe plug and cable, from probe rod assembly located on cover, to allow the fill valve to re-energize and overflow humidifier tank. This process will only take a few seconds, you must then reconnect it. A call for humidity will then energize the heating element.

Low Water Protection

During operation, the water line eventually drops to level "B", at this time the fan and heater are de-energized and the water fill valve opens. The fan and heater will remain "OFF" until the water line has been restored to level "A". This then also provides low water protection in the event of water supply failure.

This "idle during refill" feature results in the unit being inactive about 3% of the "ON" time.

LW415 (Units shipped after 12/89.)

Initial Start-Up

When the power is first turned on, the solenoid operated water fill valve opens and begins filling the vaporizing chamber. Filling will continue until water reaches level "A", the fill valve closes. To ensure that a water seal is created in the overflow hose, disconnect probe plug and cable, from probe rod assembly located on cover, to allow the fill valve to re-energize and overflow humidifier tank. This process will only take a few seconds, you must then reconnect it. A call for humidity will then energize the heating element.

Water Refill

During operation the water line will drop to level "B". At this time the fill valve opens. The fill valve will remain open until the water line returns to level "A".

Low Water Protection

During operation, the water line will drop to level "C", the heaters will then be de-energized. The heaters will remain "OFF" until the water line has been restored to level "C". This action provides low water protection in the event of water supply failure.

Surface Skimming

Each time the vaporizing chamber refills, the upper 1/4" of water is immediately drained off through the "skimmer". This carries away the floating mineral residue that was formed during the previous evaporating cycle. This skimming action very effectively removes most of the mineral concentration in much the same way as the surface blowdown does in a steam boiler.

This simple device greatly reduces the frequency of cleaning the vaporizing chamber.

Drain/Flush Feature

This control module contains an integral electronic timer which accumulates the "ON" or "humidifying" time of the unit. When this accumulated time reaches what has been set in the timer, the drain/flush cycle is activated.

Upon activation, the following sequence

occurs:

1. The drain valve opens and the mineral-rich water in the vaporizing chamber begins draining.
2. When this water drops to the "REFILL" level, the fill valve opens.
3. The drain and fill valves remain open for ten more minutes, thus flushing the chamber.
4. The drain valve then closes...the chamber refills...the fill valve closes...the timer begins accumulating time and the unit resumes normal operation.

The electronic timer comes factory-set for drainage at 40 hours of accumulated time. Alternate settings of 20 hours and 80 hours can be made. See wiring diagrams on page 9 for timer board location and instructions for changing the timer setting.

Test Cycling the Drain/Flush System

The timer board contains four pairs of terminal pins which are marked 20, 40, 80 and "T" (TEST). To test:

1. Pull the pin block off whichever pair of pins is in use, move it to the "T" pair and push it on.
2. Set the humidistat high enough so the unit will remain "on call" for at least one hour.
3. After about 35 minutes of running time, activation will take place, causing the "drain" valve to open. The water level will then drop and cause the "fill" valve to open. Both valves will remain open for about 10 minutes.
4. The "drain" valve will then close and the water level will rise, causing the "fill" valve to close.
5. Once the test cycle is completed, move the pin block back to the appropriate hourly pair of pins. Failure to do so will result in a drain/flush cycle every 35 minutes.

OPERATION

VAPORMIST DI

The VAPORMIST DI should follow the same basic rules for humidifier location and mounting as is required for the standard unit. See page 4 for location and mounting methods and page 6 for drain piping.

Makeup Water Piping

Use cold or hot makeup water. If the water pressure is above 60 psi and/or water hammer would be objectionable, a pressure reducing valve or shock arrester should be installed. Even though the VAPORMIST has an internal 1" air gap, some local codes may require a vacuum breaker.

Warning: Minimum water supply pressure is 10 psi.

The basic water level system and low water protection circuit found on page 7 is common to all DI humidifiers.

Caution: Only qualified electrical personnel should perform installation and startup procedures.

Mounting

Check mounting to see that unit is level and securely supported before filling with water.

Piping

Verify that all piping connections have been completed as recommended and that water pressure is available.

Electrical

Verify that all wiring connections have been made in accordance with the VAPORMIST wiring diagram.

Control Circuit

- a) Adjust humidistat to "call" setting.
- b) Open shut off valve on water supply line. Unit should begin filling through operated fill valve.
- c) Shortly before fill valve shuts off, the low water cutoff switch will "make". When this switch makes, the heating element contactor(s) will be actuated after a ten second delay. A time delay relay prevents contactor chatter due to bouncing of low water cutoff float.
- d) Check low water cutoff circuit.
 1. Close manual top valve on water supply.
 2. Open ball valve and start draining unit.
 3. When water level drops past switching level on the low water cutoff float, the heating element contactor(s) will drop out.
 4. When step 3 has been satisfactorily completed, close drain valve.
- e) Check out function of field installed safety controls such as fan proving switch etc. Contactor(s) should drop out when any proving switch is "open".
- f) Check heater draw by testing and recording voltage and amperage in each phase. Readings should match nameplate readings - nameplate is located on the humidifier housing.
- g) Inspect installations for leaks by operating the VAPORMIST. Any steam or air leaks should be sealed.

MAINTENANCE PROCEDURE

Mineral Precipitate

As vaporization takes place in a standard VAPORMIST, the minerals dissolved in the water precipitate (come out of solution) and a portion of these minerals float on the water surface. If not removed, this precipitated mineral will eventually form a sludge and settle to the bottom of the vaporizing chamber.

Floating Mineral Precipitate is Removed By Skimmer and Timer/Drain/Flush System (Standard VAPORMIST only)

Each time the make-up valve opens, the unit refills to a point just above the skimmer opening. A portion of the make-up water is then "skimmed" (flows to drain), carrying the floating mineral with it. This action reduces the mineral concentration in the VAPORMIST unit, which in turn reduces the frequency of cleaning.

Cleaning once or twice a season is usually adequate, assuming the water has a hardness of up to 15 grains of dissolved mineral per gallon.

In addition to the skimmer, a timer and drain/flush system is incorporated into the operating system (see page 11 for operation description). The timer is field adjustable for 20, 40, 80 hours of humidifier accumulated "ON" time between drain/flush operations. Drain/flush duration is 10 minutes.

Cleaning the Evaporating Chamber

The heating element itself is self cleaning. The mineral buildup on the element flakes off after reaching a thickness of about 1/16", and settles to the bottom of the chamber.

Before this scale accumulation builds up to the underside of the heating element, it must be removed. Failure to do so may result in premature heater burn-out.

The VAPORMIST humidifier is designed to make regular cleaning and maintenance easy and quick.

To Service: (Refer to photo on page 14)

1. Shut off electrical power to the unit. Using the key, unlock and remove the

large front panel. Drain the vaporizing chamber by manually opening the "DRAIN" valve. Do this by pushing open the lever on the valve to the "MANUAL" position and lock in place.

2. Disconnect the flexible vapor hose (A) on top of the vaporizing chamber. Disconnect the flexible hose from the overflow pipe (B) and the flexible hose from the drain (C). Install rubber plug into tank drain nipple. All disconnects can be made on the vaporizing chamber. NOTE: DO NOT DISCONNECT THE FLEXIBLE POWER ELECTRICAL CONDUIT (XXX).
3. Disconnect tank grounding wire.
4. Slide the vaporizing chamber out of the unit on the sliding track (D). Remove the cover of the chamber, raise, and slide into holding slots (E).
5. Remove the soiled vaporizing chamber and clean.
6. Unscrew the thermoplastic probe housing and remove any mineral build-up that may have accumulated in the housing.
7. Clean the probe-rod assembly. Since it is completely TEFLON® coated except for the tips, scale flakes off easily. Build-up on tips should be scraped off, then tips brushed to remove any mineral residue.
8. Replace cleaned chamber onto the sliding track.
9. Replace the chamber cover making sure the chamber is sealed tight. Push chamber back into the unit on the slide track.
10. Reconnect the flexible vapor hose (A), the overflow hose (B), the drain hose (C) and connect tank ground wire.
11. Return drain valve lever to "AUTO".
12. Replace the front panel and lock. Turn on the electric power. VAPORMIST is again ready to humidify.

Off Season Shut-Down

1. Switch off power.
2. Turn off water supply to make-up valve.

3. Drain evaporation chamber and clean if necessary (see previous steps 1-8).
4. Leave chamber dry, the power "OFF" and the water shutoff valve closed until the next humidification season.

VAPORMIST DI Maintenance Procedure

The VAPORMIST DI unit uses DI/RO water. Because these water types are mineral-free you never need to clean the vaporizing chamber. However there are some simple maintenance steps that should be followed to ensure all parts of the unit are in good working order.

1. Shut off electric power to unit.
2. Shut off water supply to make-up valve.
3. Unlock and remove front panel
4. Make sure the vaporizing chamber is drained by manually opening the 'drain' valve (A).
5. **Check the condition of the overflow (B) and drain (C) hoses.**
6. Remove the vaporizing chamber as follows: Disconnect the flexible vapor hose (D) on top of the vaporizing chamber, the flexible overflow hose (B) and the flexible drain hose (C). All disconnects should be made at the vaporizing chamber. DO NOT DISCONNECT ANY OF THE ELECTRICAL CONDUITS (E).
7. Slide the vaporizing chamber forward on the track. Remove the cover of the chamber, raise and slide into holding slots (G).
8. **Check operation of the float valve (H) and low water cut-off (J).**
9. **Inspect the heating elements.** Replace if badly pitted.
10. **Inspect the vaporizing chamber.** Clean if necessary.
11. Replace the chamber cover and slide chamber back into unit.

(Continued on next page.)

MAINTENANCE PROCEDURE

VAPORMIST

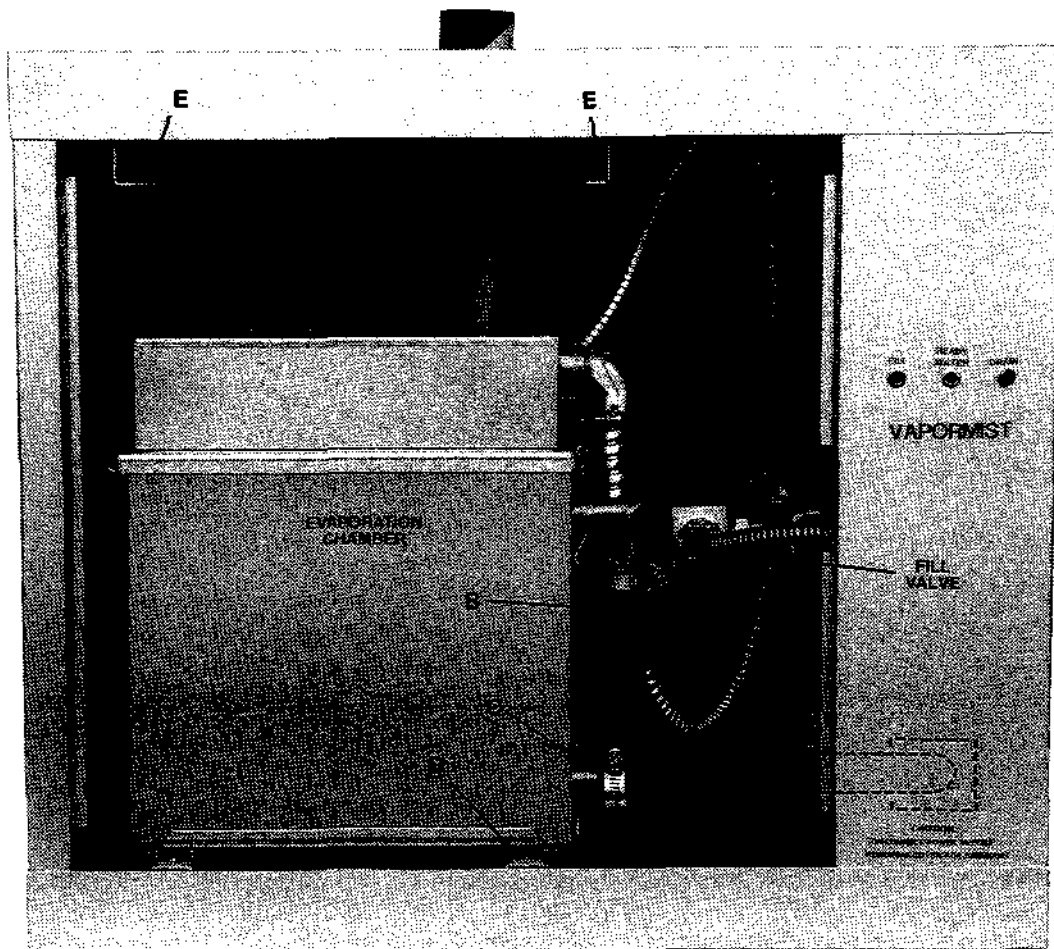

VAPORMIST DI Maintenance Procedure (continued)

12. Reconnect all flexible hoses.
 13. Return drain valve handle (A) to 'closed' position.
 14. Replace front panel and turn on electric power.
 15. VAPORMIST DI is again ready to humidify.
4. Drain vaporizing chamber by manually opening the 'drain' valve.
 5. Replace front panel.
 6. Leave chamber dry, power off, and water shut off valve closed - until the next humidification season.

Off Season Shut-Down Procedure

1. Switch off electric power to unit.
2. Remove front panel.
3. Shut off water supply to make-up valve.

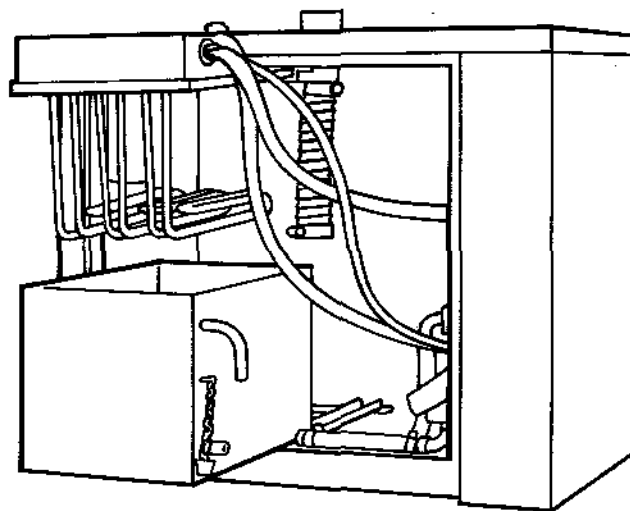

REPLACEMENT PARTS

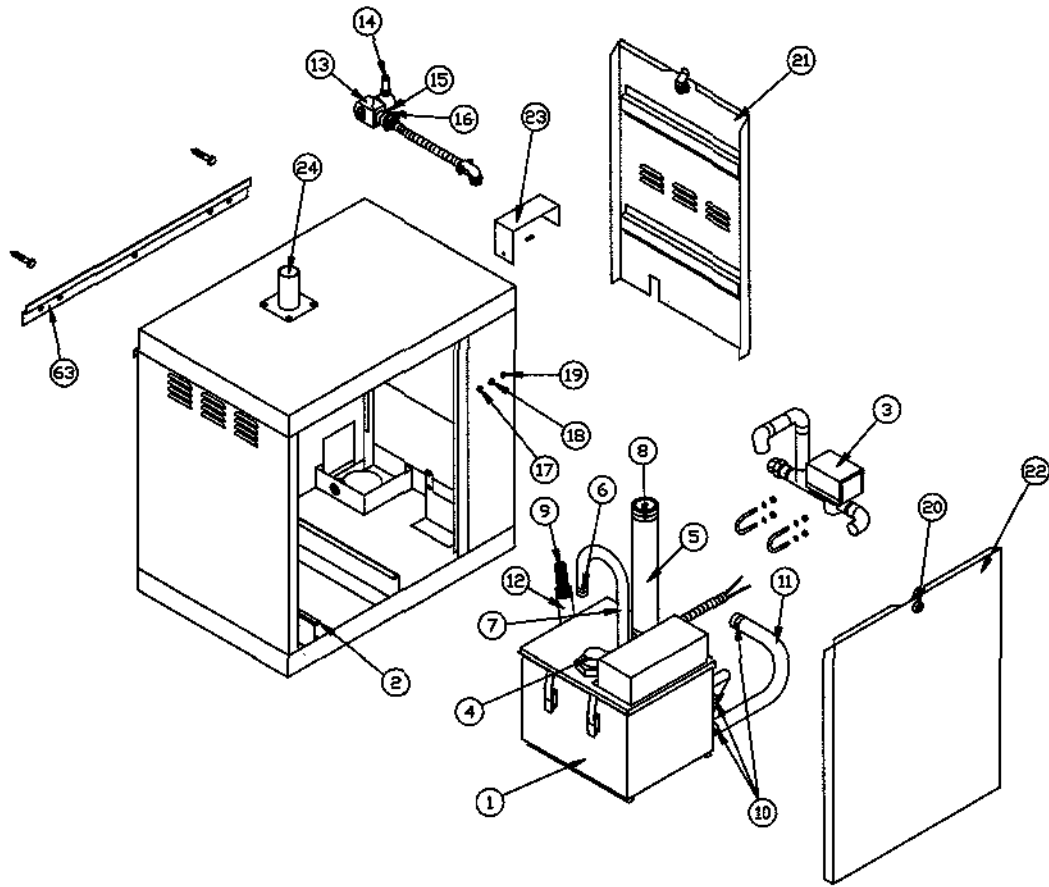

OM-214

VAPORMIST

No.	Description	Qty.	Part No.
1	Vaporizer Tank Assembly	1	3*
2	15" Nylon Strip	2	309980
3	Drain Assembly	1	3*
4	Probe Plug Cap - 24"	1	406050-002
5	Vapor Hose 1-1/2" x 12" (VM2, 4)	0-1	305390-004
5	Vapor Hose 1-1/2" x 10" (VM6, 8, 10)	0-1	305390-003
5	Vapor Hose 1-1/2" x 8" (VM12, 16)	0-1	305390-002
6	1/2" Hose Clamp	2	700560-001
7	1/2" Fill Hose - 21" Long	1	307020-001
8	1-1/2" Hose Clamp	2	700560-003
9	Overflow Hose Spring	1	307025
10	3/4" Hose Clamp	4	700560-002
11	3/4" x 8-1/2" Drain Hose (VM2, 4)	0-1	307020-002
11	3/4" x 7-1/2" Drain Hose (VM6, 8, 10, 12, 16)	0-1	307020-002

No.	Description	Qty.	Part No.
12	3/4" x 16" Overflow Hose (VM2, 4)	0-1	307020-002
12	3/4" x 15" Overflow Hose (VM6, 8, 10)	0-1	307020-002
12	3/4" x 19" Overflow Hose (VM12, 16)	0-1	307020-002
13	24 Volt Fill Valve	1	505080-001
14	Restriction Orifice Nipple	1	203530
15	1/4" Brass Close Nipple	1	203560
16	Sediment Strainer	1	300050
17	Amber Light (FILL)	1	409520-003
18	Green Light (READY WATER)	1	409520-002
19	Red Light (DRAIN)	1	409520-001
20	Key Lock	2	700700
21	Electrical Cover	1	160320-100
22	Front Panel	1	160310-100
23	Electrical Cover Keylock Bracket	1	120746
24	Vapor Hose Connector - 1*	1	160350

1* - Shipped loose except with bonding bracket.

3* - See separate drawing.

REPLACEMENT PARTS

VAPORMIST - Vaporizer Tank

No.	Description	Qty.	Part No.
27	Small Vaporizer Tank (VM2, 4)	1	160010-001
27	Large Vaporizer Tank (VM6, 8, 10)	1	160010-002
27	VM-12, 16 Vaporizer Tank	1	160010-003
28	Small 1 heater Cover (VM2)	1	160020-001
28	Small 2 heater Cover (VM4)	1	160020-002
28	Large 2 heater Cover (VM6, 8)	1	160021-001
28	Large 3 heater Cover (VM10, 12, 16)	1	160021-002
29	Probe Gasket	1	309750-003
30	Thermo Cut-Out	1	409560-001
31	Sm. Heater Terminal Cover (VM2, 4)	1	160110-001
32	Heater Terminal Cover (VM6, 8, 10)	1	160110-002
32	VM-16 Heater Terminal Cover	1	160110-003
33	Small Cover Gasket (VM2, 4)	1	309950-001
33	Large Cover Gasket (VM6, 8, 10, 12, 16)	1	309950-002
34	Probe Housing	1	308500
35	Heater	1*	
36	Rubber Stopper	1	309960
37	Draw Latch	4	700455

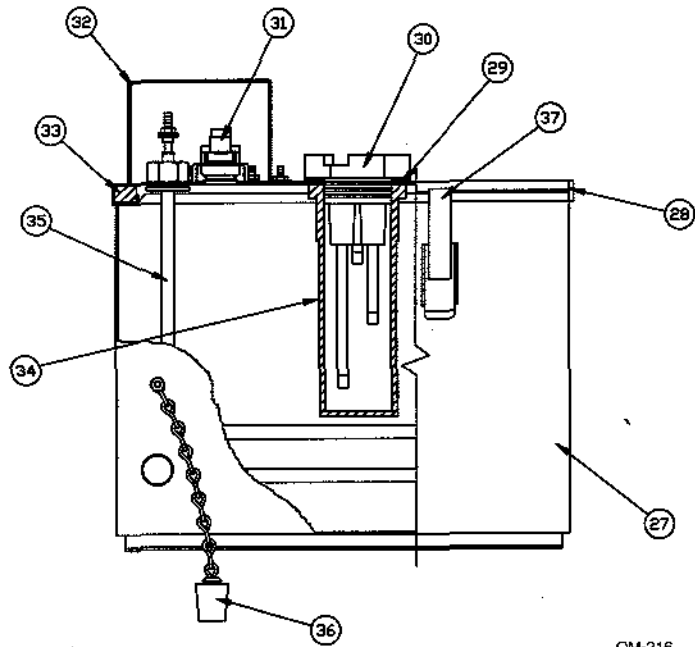

OM-216

1* - Refer to specific order for quantity and type.

VAPORMIST - Subpanel

No.	Description	Qty.	Part No.
44	Transformer 75 VA - 3*	1	408970-tab
45	TP Modulator S10A - 1*, 3*	1	408680-tab
46	JC Contactor 24V w/Aux. Switch - 3*	1	407001-tab
47	LW415-BA-24V Level & Timer Board	1	408630
48	Kwik Disconnect Terminal Board	1	409580-002
49	Terminal Block 6 pt.	1	408250-011
50	Terminal Block 3 pt. Pressure Contact	1	408300-002
51	Interlock Switch - 1*	1	408470
54	Wire Harness, VM (Not Shown)	1	409990

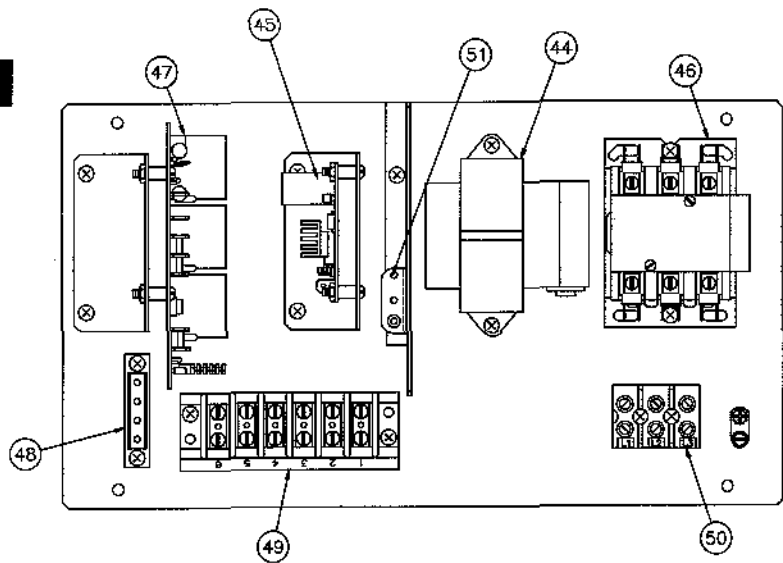

1* - Optional

3* - Refer to individual order for correct selection.

OM-210

REPLACEMENT PARTS

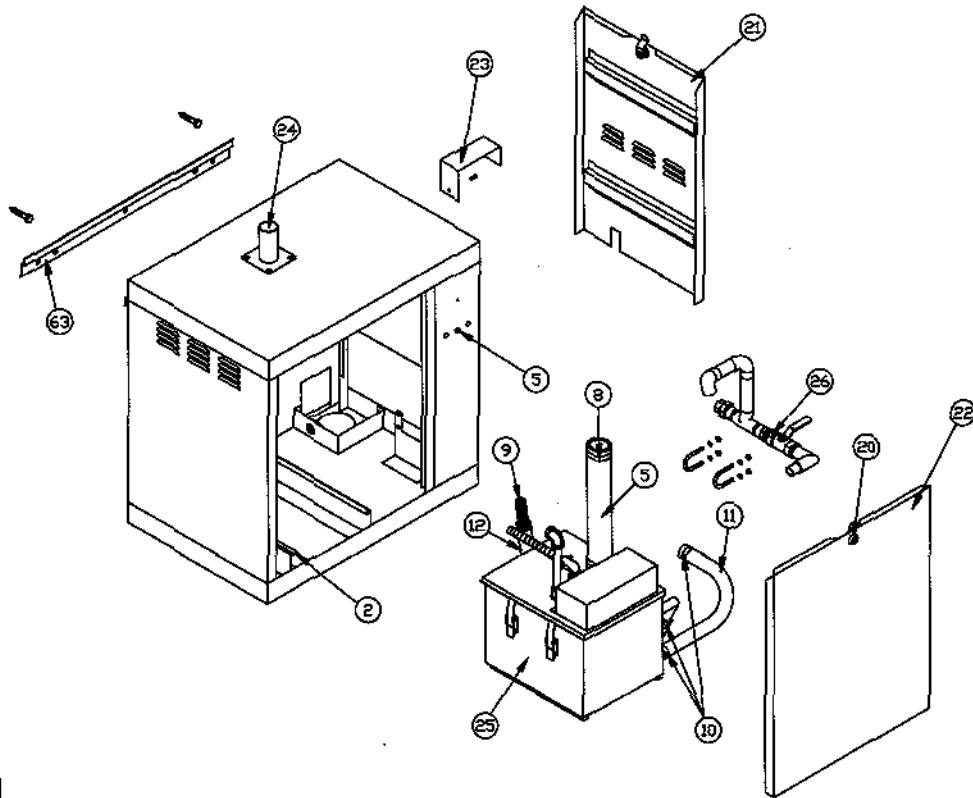

OM-215

VAPORMIST DI

No.	Description	Qty.	Part No.
2	15" Nylon Strip	2	309980
5	Vapor Hose 1-1/2" x 12" (VMDI2, 4)	0-1	305390-004
5	Vapor Hose 1-1/2" x 10" (VMDI6, 8, 10)	0-1	305390-003
5	Vapor Hose 1-1/2" x 8" (VMDI12, 16)	0-1	305390-002
8	1/2" Hose Clamp	2	700560-003
9	Overflow Hose Spring	1	307025
10	3/4" Hose Clamp	4	700560-002
11	3/4" x 8-1/2" Drain Hose (VMDI2, 4)	0-1	307020-002
11	3/4" x 7-1/2" Drain Hose (VMDI6, 8, 10, 12, 16)	0-1	307020-002
12	3/4" x 16" Overflow Hose (VMDI2, 4)	0-1	307020-002
12	3/4" x 15" Overflow Hose (VMDI6, 8, 10)	0-1	307020-002
12	3/4" x 19" Overflow Hose (VMDI12, 16)	0-1	307020-002
18	Green Light (READY WATER)	1	409520-002
20	Key Lock	2	700700
23	Electrical Cover Keylock Bracket	1	120746
24	Vapor Hose Connector - 1"	1	180350
25	Vaporizer Tank Assembly	1	3*
26	Drain Assembly	1	3*

1* - Shipped loose except with bonding bracket.

3* - See separate drawing.

REPLACEMENT PARTS

VAPORMIST DI - Vaporizer Tank

No.	Description	Qty.	Part No.
27	Small Vaporizer Tank (VMDI2, 4)	1	160010-001
27	Large Vaporizer Tank (VMDI6, 8, 10)	1	160010-002
27	VMDI-12, 16 Vaporizer Tank	1	160010-003
31	Thermo Cut-Out	1	409560-001
32	Sm Heater Terminal Cover (VMDI2, 4)	1	160110-001
32	Heater Terminal Cover (VMDI6, 8, 10)	1	160110-002
32	VMDI-16 Heater Terminal Cover	1	160110-003
33	Small Cover Gasket (VMDI2, 4)	1	309950-001
33	Large Cover Gasket (VMDI6, 8, 10, 12, 16)	1	309950-002
35	Heater	1*	
36	Rubber Stopper	1	309960
37	Draw Latch	4	700455
38	Small 1 heater Cover (VMDI2)	1	160200-001
38	Small 2 heater Cover (VMDI4)	1	160200-002
38	Large 2 heater Cover (VMDI6, 8)	1	160201-001
38	Large 3 heater Cover (VMDI10, 12, 16)	1	160201-002
39	Float Switch	1	408420
40	Float Valve Assembly	1	505220
41	Fill Valve Tube	1	160210
42	1/4" 90° Elbow - SST	1	200580
43	1/4" NPT Seal Ring	1	306365

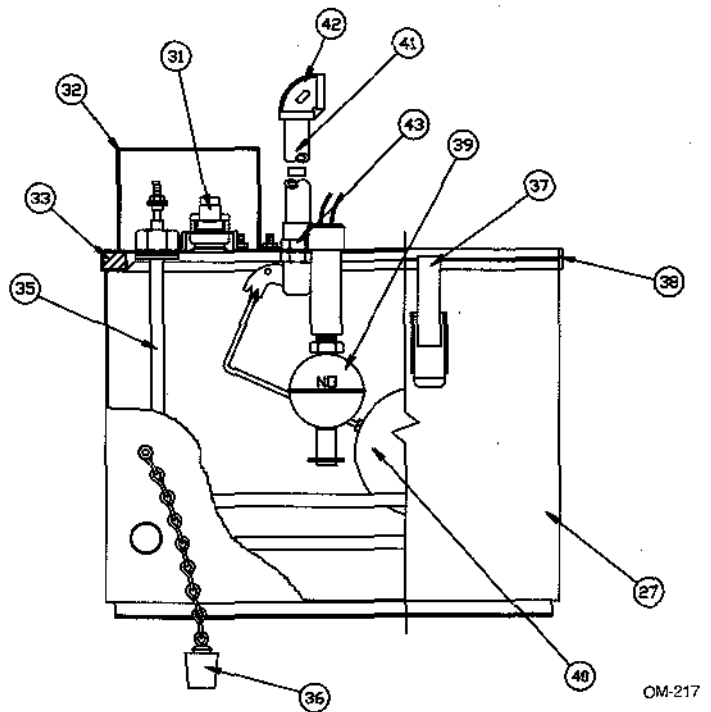

1* - Refer to specific order for quantity and type.

VAPORMIST DI - Subpanel

No.	Description	Qty.	Part No.
44	Transformer 75 VA	1	2*
45	TP Modulator S10A - 3*	1	408680
46	JC Contactor 30A/50A	1	407000-001/003
48	Kwik Disconnect Terminal Board	1	409580-001
49	Terminal Block 6 pt.	1	408250-011
50	Terminal Block 3 pt. Pressure Contact	1	408300-002
51	Interlock Switch - 3*	1	408470
54	Wire Harness, VM (Not Shown)	1	409990

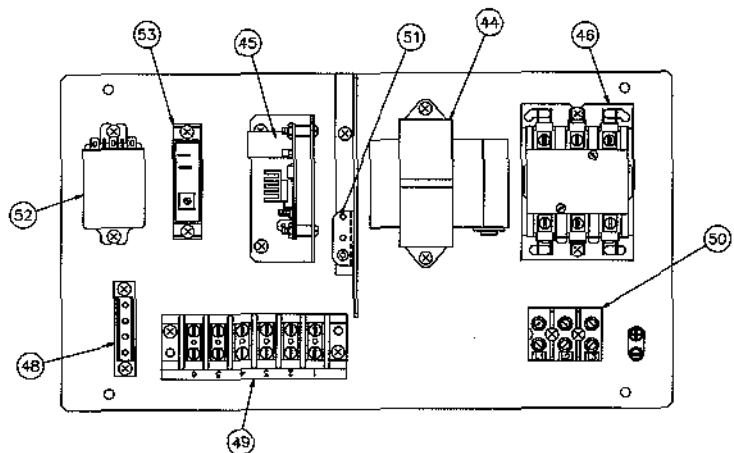

2* - Refer to individual order.

3* - Optional.

REPLACEMENT PARTS

Space Distribution Unit (SDU)

No.	Description	Qty.	Part No.
8	Hose Clamp, 1- 1/2"	2	700560-003
20	Cabinet Door Lock	2	700700
55	Door Weldment	2	160430-100
56	Vapor Hose Connector Weldment	1	160351
57	Dispersion Chamber Weldment	1	160440
58	Hose, 1 - 1/2" Wire Reinforced	.33 ft	305400-001
59	Fan Switch	1	409597
60	Blower, 40-565, 290/435 CFM	1	409540-001
61	Nut Retainer Assy, 1/4" - 20	4	700650
62	Bump-on Protective Bumpers	4	310170
63	Wall Bracket	1	160150-102
64	Plug, 1/4" NPT Yellow Brass	1	203570

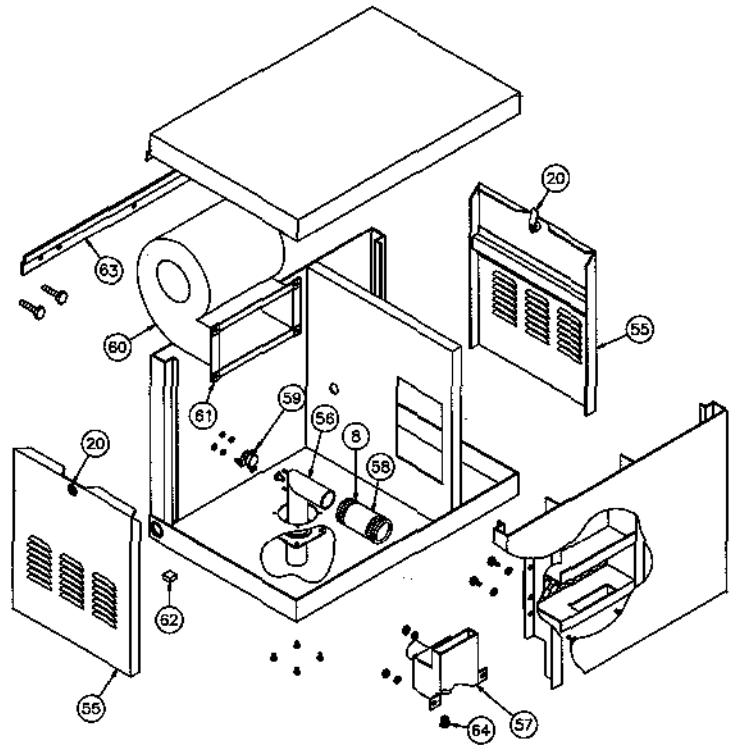

OM-212

SDU Subpanel

No.	Description	Qty.	Part No.
65	Start Relay 2 Pole 24V	1	407900-001
66	Fuse Holder Single Pole	2*	407450-002
67	Fuse, 3 amp	2*	406740-006
68	Terminal Block 2 pt pressure contact	1	408300-001
69	Terminal Block 4 pt	1	408250-001
70	Transformer - 1*	1	408991 /408992

1* - Refer to individual order for correct selection.
2* - With 480V or 575V use quantity (1).

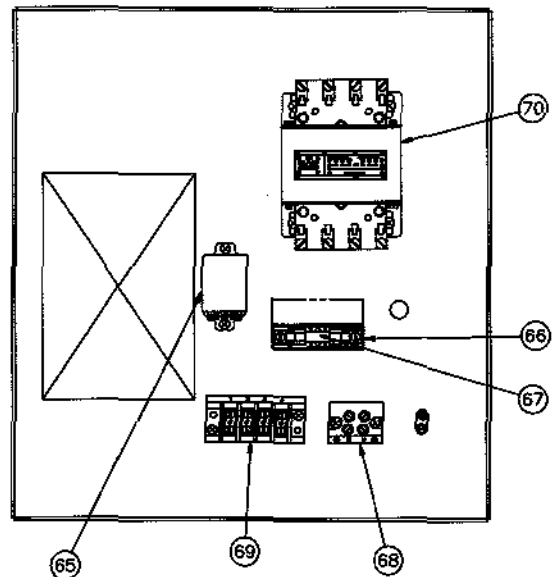

OM-213

MAINTENANCE SERVICE RECORD

DATE INSPECTED	PERSONNEL	OBSERVATION	ACTIONS PERFORMED

DRI-STEEM 2 Year Limited Warranty

DRI-STEEM Humidifier Company ("DRI-STEEM") warrants to the original user that its products will be free from defects in materials and workmanship for a period of two (2) years after installation or twenty-seven (27) months from the date DRI-STEEM ships such product, whichever date is the earlier.

If any DRI-STEEM product is found to be defective in material or workmanship during the applicable warranty period, DRI-STEEM's entire liability, and the purchaser's sole and exclusive remedy, shall be the repair or replacement of the defective product, or the refund of the purchase price, at DRI-STEEM's election. DRI-STEEM shall not be liable for any costs or expenses, whether direct or indirect, associated with the installation, removal or re-installation of any defective product.

DRI-STEEM's limited warranty shall not be effective or actionable unless there is compliance with all installation and operating instructions furnished by DRI-STEEM, or if the products have been modified or altered without the written consent of DRI-STEEM, or if such products have been subject to accident, misuse, mishandling, tampering, negligence or improper maintenance. Any warranty claim must be submitted to DRI-STEEM in writing within the stated warranty period.

DRI-STEEM's limited warranty is made in lieu of, and DRI-STEEM disclaims all other warranties, whether express or implied, including but not limited to any IMPLIED WARRANTY OF MERCHANTABILITY, ANY IMPLIED WARRANTY OF FITNESS FOR A PARTICULAR PURPOSE, any implied warranty arising out of a course of dealing or of performance, custom or usage of trade.

DRI-STEEM SHALL NOT, UNDER ANY CIRCUMSTANCES BE LIABLE FOR ANY DIRECT, INDIRECT, INCIDENTAL, SPECIAL OR CONSEQUENTIAL DAMAGES (INCLUDING, BUT NOT LIMITED TO, LOSS OF PROFITS, REVENUE OR BUSINESS) OR DAMAGE OR INJURY TO PERSONS OR PROPERTY IN ANY WAY RELATED TO THE MANUFACTURE OR THE USE OF ITS PRODUCTS. The exclusion applies regardless of whether such damages are sought based on breach of warranty, breach of contract, negligence, strict liability in tort, or any other legal theory, even if DRI-STEEM has notice of the possibility of such damages.

By purchasing DRI-STEEM's products, the purchaser agrees to the terms and conditions of this limited warranty.

DRI-STEEM[®]
HUMIDIFIER COMPANY

14949 Technology Drive, Eden Prairie, MN 55344
PH: 1-800-328-4447 • In MN: (612)949-2415
Fax: (612)949-2933

