

Dechlorinator specifications

DECHLORINATOR

The dechlorinator removes chlorine from the water that degrades the reverse osmosis membranes.

120V, single-phase, 60 Hz, 5A electrical service is required for all dechlorinator models, except for the DC-CB dechlorinator (requires no electrical service).

FIGURE 1-2: WALL MOUNT DECHLORINATOR



FIGURE 1-1: DECHLORINATOR



Table 1-1:
Dechlorinator specifications

Dechlorinator model*	Media volume	Dimensions, diameter x height	Connections, in /out	Backwash flow**	Shipping weight***
DC-CB	Carbon black filter	4" x 20" (102 x 508 mm)	1"	—	—
DC-744	0.5 ft ³ (0.014 m ³)	7" x 44" (178 x 1118 mm)	1"	2.7 gpm (10.2 L/m)	100 lbs (45.4 kg)
DC-844	0.75 ft ³ (0.021 m ³)	8" x 44" (203 x 1118 mm)	1"	3.2 gpm (12.1 L/m)	115 lbs (52.2 kg)
DC-948	1.00 ft ³ (0.028 m ³)	9" x 48" (229 x 1219 mm)	1"	4.2 gpm (15.9 L/m)	130 lbs (59.0 kg)
DC-1054	1.50 ft ³ (0.042 m ³)	10" x 54" (254 x 1372 mm)	1"	5.3 gpm (20.1 L/m)	150 lbs (68.0 kg)
DC-1252	2.00 ft ³ (0.050 m ³)	12" x 52" (305 x 1321 mm)	1"	7.5 gpm (28.4 L/m)	190 lbs (86.2 kg)
DC-1354	2.50 ft ³ (0.071 m ³)	13" x 54" (330 x 1372 mm)	1"	10.0 gpm (37.9 L/m)	225 lbs (102.1 kg)
DC-1465	3.00 ft ³ (0.085 m ³)	14" x 65" (356 x 1651 mm)	1"	12.0 gpm (45.4 L/m)	335 lbs (152.0 kg)
DC-1665	4.00 ft ³ (0.113 m ³)	16" x 65" (406 x 1651 mm)	1"	15.0 gpm (56.8 L/m)	385 lbs (174.6 kg)
DC-2162	6.00 ft ³ (0.170 m ³)	21" x 62" 6(533 x 1575 mm)	1.5"	25.0 gpm (94.6 L/m)	645 lbs (292.6 kg)
DC-2472	8.00 ft ³ (0.227 m ³)	24" x 72" (610 x 1829 mm)	1.5"	33.0 gpm (124.9 L/m)	950 lbs (430.9 kg)
DC-3072	12.50 ft ³ (0.354 m ³)	30" x 72" (762 x 1829 mm)	2"	50.0 gpm (189.3 L/m)	1535 lbs (696.3 kg)

* DC-CB is wall mounted; all other models are floor mounted.

** Based on 60 to 90 psi (415 to 620 kPa) inlet pressure.

*** DC-2162, DC-2472, and DC-3072 media shipped separate, but included in shipping weight total.

Single water softener specifications

WATER SOFTENER AND BRINE TANK

The water softener and brine tank are floor-mounted and exchange water hardness for sodium.

120V, single-phase, 60 Hz, 5A electrical service is required for all water softener models.

FIGURE 2-1: SINGLE WATER SOFTENER AND BRINE TANK

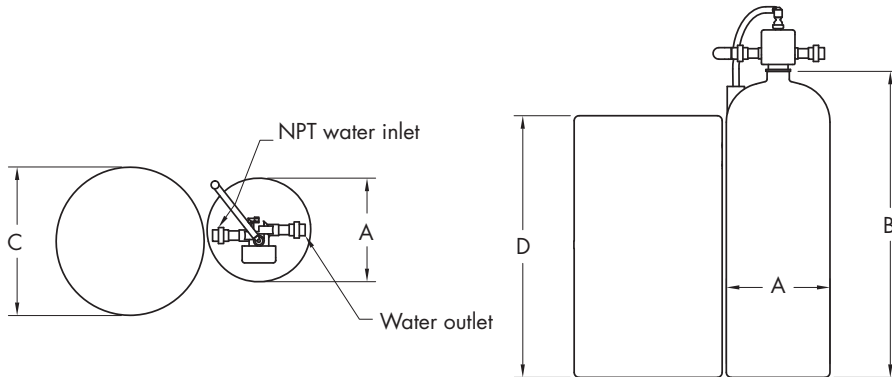

Table 2-1:
Single softener and brine tank specifications

Softener model	Media volume per tank	Resin tank diameter (A) x height (B) (per tank)	Connections, in/out	Backwash flow**	Brine tank diameter (C) x height (D)	Shipping weight***
WS-744	0.5 ft ³ (0.014 m ³)	7" x 44" (178 x 1118 mm)	1"	1.35 gpm (4.9 L/m)	18" x 33" (457 x 838 mm)	110 lbs (49.9 kg)
WS-844	0.75 ft ³ (0.021 m ³)	8" x 44" (203 x 1118 mm)	1"	1.70 gpm (6.4 L/m)	18" x 40" (457 x 1016 mm)	125 lbs (56.7 kg)
WS-948	1.00 ft ³ (0.028 m ³)	9" x 48" (229 x 1219 mm)	1"	2.2 gpm (8.3 L/m)	18" x 40" (457 x 1016 mm)	140 lbs (63.5 kg)
WS-1054	1.50 ft ³ (0.042 m ³)	10" x 54" (254 x 1372 mm)	1"	2.7 gpm (10.2 L/m)	18" x 40" (457 x 1016 mm)	160 lbs (72.6 kg)
WS-1252	2.00 ft ³ (0.050 m ³)	12" x 52" (305 x 1321 mm)	1"	3.2 gpm (12.1 L/m)	18" x 40" (457 x 1016 mm)	200 lbs (90.7 kg)
WS-1354	2.50 ft ³ (0.071 m ³)	13" x 54" (330 x 1372 mm)	1"	4.2 gpm (15.9 L/m)	18" x 40" (457 x 1016 mm)	235 lbs (106.6 kg)
WS-1465	3.00 ft ³ (0.085 m ³)	14" x 65" (356 x 1651 mm)	1"	5.3 gpm (20.1 L/m)	24" x 41" (610 x 1041 mm)	345 lbs (156.5 kg)
WS-1665	4.00 ft ³ (0.113 m ³)	16" x 65" (406 x 1651 mm)	1"	6.5 gpm (24.6 L/m)	24" x 41" (610 x 1041 mm)	395 lbs (179.2 kg)
WS-2162	6.00 ft ³ (0.170 m ³)	21" x 62" (533 x 1575 mm)	1.5"	12.0 gpm (45.4 L/m)	30" x 48" (762 x 1219 mm)	655 lbs (297.1 kg)
WS-2472	8.00 ft ³ (0.227 m ³)	24" x 72" (610 x 1829 mm)	1.5"	15.0 gpm (56.8 L/m)	39" x 48" (991 x 1219 mm)	960 lbs (435.4 kg)
WS-3072	12.50 ft ³ (0.354 m ³)	30" x 72" (762 x 1829 mm)	2"	25.0 gpm (94.6 L/m)	39" x 48" (991 x 1219 mm)	1545 lbs (701.0 kg)

** Based on 60 to 90 psi (415 to 620 kPa) inlet pressure.

*** WS-2162, WS-2472, and WS-3072 media shipped separate, but included in shipping weight total.

Duplex water softener specifications

WATER SOFTENER AND BRINE TANK

The water softener and brine tank are floor-mounted and exchange water hardness for sodium.

120V, single-phase, 60 Hz, 5A electrical service is required for all water softener models.

FIGURE 3-1: DUPLEX WATER SOFTENER AND BRINE TANK

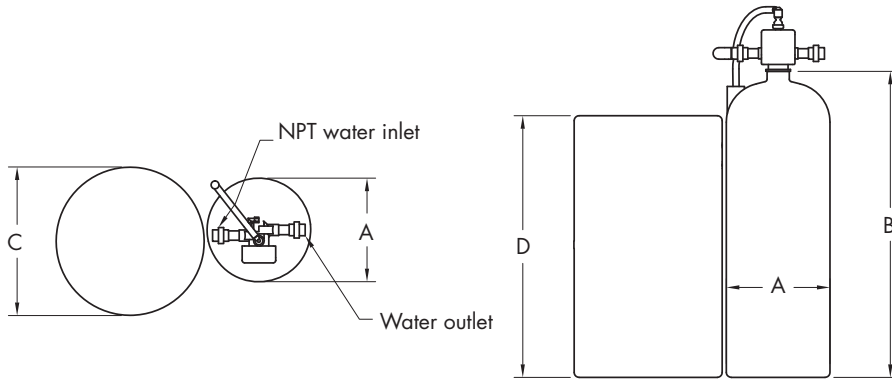

Table 3-1:
Duplex softener and brine tank specifications

Softener model*	Media volume per tank	Resin tank diameter (A) x height (B) (per tank)	Connections, in/out	Backwash flow**	Brine tank diameter (C) x height (D)	Shipping weight
WD-744	0.5 ft ³ (0.014 m ³)	7" x 44" (178 x 1118 mm)	1"	1.35 gpm (4.9 L/m)	100 lbs (45.4 kg)	210 lbs (95.3 kg)
WD-844	0.75 ft ³ (0.021 m ³)	8" x 44" (203 x 1118 mm)	1"	1.7 gpm (6.4 L/m)	18" x 40" (457 x 1016 mm)	250 lbs (113.4kg)
WD-948	1.00 ft ³ (0.028 m ³)	9" x 48" (229 x 1219 mm)	1"	2.2 gpm (8.3 L/m)	18" x 40" (457 x 1016 mm)	270 lbs (122.5 kg)
WD-1054	1.50 ft ³ (0.042 m ³)	10" x 54" (254 x 1372 mm)	1"	2.7 gpm (10.2 L/m)	18" x 40" (457 x 1016 mm)	310 lbs (140.6 kg)
WD-1252	2.00 ft ³ (0.050 m ³)	12" x 52" (305 x 1321 mm)	1"	3.2 gpm (12.1 L/m)	18" x 40" (457 x 1016 mm)	390 lbs (176.9 kg)
WD-1354	2.50 ft ³ (0.071 m ³)	13" x 54" (330 x 1372 mm)	1"	4.2 gpm (15.9 L/m)	18" x 40" (457 x 1016 mm)	460 lbs (208.7 kg)
WD-1465	3.00 ft ³ (0.085 m ³)	14" x 65" (356 x 1651 mm)	1"	5.3 gpm (20.1 L/m)	24" x 41" (610 x 1041 mm)	680 lbs (308.4 kg)
WD-1665	4.00 ft ³ (0.113 m ³)	16" x 65" (406 x 1651 mm)	1"	6.5 gpm (24.6 L/m)	24" x 41" (610 x 1041 mm)	778 lbs (352.9 kg)

** Based on 60 to 90 psi (415 to 620 kPa) inlet pressure.

Duplex water softener specifications

FIGURE 4-1: DUPLEX WATER SOFTENER AND BRINE TANK



Table 4-1:
Duplex softener and brine tank specifications

Softener model*	Media volume per tank	Resin tank diameter (A) x height (B) (per tank)	Connections, in/out	Backwash flow**	Brine tank diameter (C) x height (D)	Shipping weight***
WD-2162	6.00 ft ³ (0.170 m ³)	21" x 62" (533 x 1575 mm)	1.5"	12.0 gpm (45.4 L/m)	30" x 48" (762 x 1219 mm)	1300 lbs (589.7 kg)
WD-2472	8.00 ft ³ (0.227 m ³)	24" x 72" (610 x 1829 mm)	1.5"	15.0 gpm (56.8 L/m)	39" x 48" (991 x 1219 mm)	1910 lbs (866.4 kg)
WD-3072	12.50 ft ³ (0.354 m ³)	30" x 72" (762 x 1829 mm)	2"	25.0 gpm (94.6 L/m)	39" x 48" (991 x 1219 mm)	3080 lbs (1397.1 kg)

** Based on 60 to 90 psi (415 to 620 kPa) inlet pressure.

*** WD-2162, WD-2472, and WD-3072 media shipped separate, but included in shipping weight total.

Optional pretreatment skid mounting

SELECT PRETREATMENT SKID MOUNTING FOR EASE OF INSTALLATION

Reduce installation cost and time by having pretreatment components come pre-assembled. The DriSteem water softener(s), brine tank, and dechlorinator have a single point water inlet, water outlet, and power for all components.

- Save time and cost on installation
- Maximize clearance
- Ensure proper installation and operation

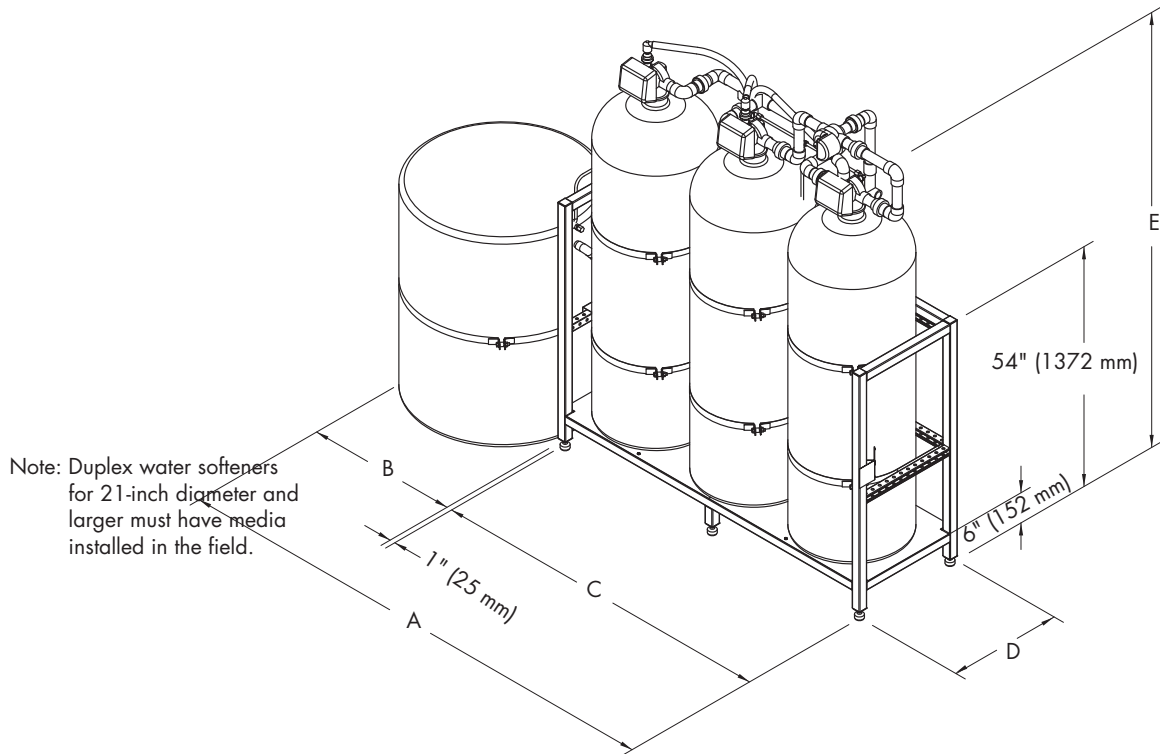

AC adapter	U.S.
Supply voltage	120 VAC
Supply frequency	60 Hz
Output voltage	12 VAC
Output current	500 mA

Skidded single water softener and dechlorinator specifications

Table 6-1:
Skidded single water softener and dechlorinator

Skid size* (outside dimensions) L x W x H	Tank quantity on skid	Media tank diameter (A) x height (B) (per tank)	Connections, in/out	Backwash flow***	Brine tank diameter (C) x height (D)	Shipping weight
52"x 26" x 54" (1321 x 660 x 1372 mm)	3	7" x 44" (178 x 1118 mm)	1"	1.35 gpm (4.9 L/m)	18" x 33" (457 x 838 mm)	370 lbs (167.8 kg)
52"x 26" x 54" (1321 x 660 x 1372 mm)	3	8" x 44" (203 x 1118 mm)	1"	1.70 gpm (6.4 L/m)	18" x 40" (457 x 1016 mm)	400 lbs (181.4 kg)
52"x 26" x 54" (1321 x 660 x 1372 mm)	3	9" x 48" (229 x 1016 mm)	1"	2.2 gpm (8.3 L/m)	18" x 40" (457 x 1016 mm)	420 lbs (190.5 kg)
52"x 26" x 54" (1321 x 660 x 1372 mm)	3	10" x 54" (254 x 1372 mm)	1"	2.7 gpm (10.2 L/m)	18" x 40" (457 x 1016 mm)	470 lbs (213.2 kg)
52"x 26" x 54" (1321 x 660 x 1372 mm)	3	12" x 52" (305 x 1321 mm)	1"	3.2 gpm (12.1 L/m)	18" x 40" (457 x 1016 mm)	530 lbs (240.4 kg)
52"x 26" x 54" (1321 x 660 x 1372 mm)	3	13" x 54" (330 x 1372 mm)	1"	4.2 gpm (15.9 L/m)	18" x 40" (457 x 1016 mm)	620 lbs (281.2 kg)
66"x 28" x 54" (1676 x 711 x 1372 mm)	3	14" x 65" (356 x 1651 mm)	1"	5.3 gpm (20.1 L/m)	24" x 41" (610 x 1041 mm)	860 lbs (390.1 kg)
66"x 28" x 54" (1676 x 711 x 1372 mm)	3	16" x 65" (406 x 1651 mm)	1"	6.5 gpm (24.6 L/m)	24" x 41" (610 x 1041 mm)	910 lbs (412.8 kg)
100"x 34" x 54" (2540 x 864 x 1372 mm)	3	21" x 62" (533 x 1575 mm)	1.5"	12.0 gpm (45.4 L/m)	30" x 48" (762 x 1219 mm)	1540 lbs (698.5 kg)
66"x 28" x 54" ** (1676 x 711 x 1372 mm)	2	24" x 72" (610 x 1829 mm)	1.5"	15.0 gpm (56.8 L/m)	39" x 48" (991 x 1219 mm)	2090 lbs (948.0 kg)
82"x 28" x 54" ** (2083 x 711 x 1372 mm)	2	30" x 72" (762 x 1829 mm)	2"	25.0 gpm (94.6 L/m)	39" x 48" (991 x 1219 mm)	3280 lbs (1487.8 kg)
* Non-skidded pre-treatment dimensions are 4" (102 mm) less.						
** Skid does not include brine tank. The brine tank is floor mounted.						
*** Based on 60 to 90 psi (415 to 620 kPa) inlet pressure.						

Skidded duplex water softener and dechlorinator specifications

Table 7-1:
Skidded duplex water softener and dechlorinator

Skid size (outside dimensions) L x W x H	Tank quantity on skid	Media tank diameter (A) x height (B) (per tank)	Connections, in/out	Backwash flow***	Brine tank diameter (C) x height (D)	Shipping weight
66"x 28" x 54" (1676 x 711 x 1372 mm)	4	7" x 44" (178 x 1118 mm)	1"	1.35 gpm (4.9 L/m)	18" x 33" (457 x 838 mm)	490 lbs (222.3 kg)
66"x 28" x 54" (1676 x 711 x 1372 mm)	4	8" x 44" (203 x 1118 mm)	1"	1.7 gpm (6.4 L/m)	18" x 40" (457 x 1016 mm)	545 lbs (247.2 kg)
66"x 28" x 54" (1676 x 711 x 1372 mm)	4	9" x 48" (229 x 1016 mm)	1"	2.2 gpm (8.3 L/m)	18" x 40" (457 x 1016 mm)	575 lbs (260.8 kg)
66"x 28" x 54" (1676 x 711 x 1372 mm)	4	10" x 54" (254 x 1372 mm)	1"	2.7 gpm (10.2 L/m)	18" x 40" (457 x 1016 mm)	640 lbs (290.3 kg)
66"x 28" x 54" (1676 x 711 x 1372 mm)	4	12" x 52" (305 x 1321 mm)	1"	3.2 gpm (12.1 L/m)	18" x 40" (457 x 1016 mm)	760 lbs (344.7 kg)
66"x 28" x 54" (1676 x 711 x 1372 mm)	4	13" x 54" (330 x 1372 mm)	1"	4.2 gpm (15.9 L/m)	18" x 40" (457 x 1016 mm)	865 lbs (392.4 kg)
82"x 28" x 54" (2083 x 711 x 1372 mm)	4	14" x 65" (356 x 1651 mm)	1"	5.3 gpm (20.1 L/m)	24" x 41" (610 x 1041 mm)	1215 lbs (551.1 kg)
82"x 28" x 54" (2083 x 711 x 1372 mm)	4	16" x 65" (406 x 1651 mm)	1"	6.5 gpm (24.6 L/m)	24" x 41" (610 x 1041 mm)	1363 lbs (618.2 kg)
82"x 28" x 54" ** (2083 x 711 x 1372 mm)	3	21" x 62" (533 x 1575 mm)	1.5"	12.0 gpm (45.4 L/m)	30" x 48" (762 x 1219 mm)	2145 lbs (972.9 kg)
82"x 28" x 54" ** (2083 x 711 x 1372 mm)	3	24" x 72" (610 x 1829 mm)	1.5"	15.0 gpm (56.8 L/m)	39" x 48" (991 x 1219 mm)	3060 lbs (1387.9 kg)
100"x 34" x 54" ** (2540 x 864 x 1372 mm)	3	30" x 72" (762 x 1829 mm)	2"	25.0 gpm (94.6 L/m)	39" x 48" (991 x 1219 mm)	4855 lbs (2202.2 kg)

* Non-skidded pre-treatment dimensions are 4" (102 mm) less.

** Skid does not include brine tank. The brine tank is floor mounted.

*** Based on 60 to 90 psi (415 to 620 kPa) inlet pressure.

Skidded duplex water softener specifications

Table 8-1:
Skidded duplex water softener

Skid size (outside dimensions) L x W x H	Tank quantity on skid	Media tank diameter (A) x height (B) (per tank)	Connections, in/out	Backwash flow***	Brine tank diameter (C) x height (D)	Shipping weight
52"x 26" x 54" (1321 x 660 x 1372 mm)	3	7" x 44" (178 x 1118 mm)	1"	1.35 gpm (4.9 L/m)	18" x 33" (457 x 838 mm)	370 lbs (167.8 kg)
52"x 26" x 54" (1321 x 660 x 1372 mm)	3	8" x 44" (203 x 1118 mm)	1"	1.7 gpm (6.4 L/m)	18" x 40" (457 x 1016 mm)	410 lbs (185.9 kg)
52"x 26" x 54" (1321 x 660 x 1372 mm)	3	9" x 48" (229 x 1016 mm)	1"	2.2 gpm (8.3 L/m)	18" x 40" (457 x 1016 mm)	430 lbs (195.0 kg)
52"x 26" x 54" (1321 x 660 x 1372 mm)	3	10" x 54" (254 x 1372 mm)	1"	2.7 gpm (10.2 L/m)	18" x 40" (457 x 1016 mm)	470 lbs (213.2 kg)
52"x 26" x 54" (1321 x 660 x 1372 mm)	3	12" x 52" (305 x 1321 mm)	1"	3.2 gpm (12.1 L/m)	18" x 40" (457 x 1016 mm)	550 lbs (249.5 kg)
52"x 26" x 54" (1321 x 660 x 1372 mm)	3	13" x 54" (330 x 1372 mm)	1"	4.2 gpm (15.9 L/m)	18" x 40" (457 x 1016 mm)	620 lbs (281.2 kg)
66"x 28" x 54" (1676 x 711 x 1372 mm)	3	14" x 65" (356 x 1651 mm)	1"	5.3 gpm (20.1 L/m)	24" x 41" (610 x 1041 mm)	860 lbs (390.1 kg)
66"x 28" x 54" (1676 x 711 x 1372 mm)	3	16" x 65" (406 x 1651 mm)	1"	6.5 gpm (24.6 L/m)	24" x 41" (610 x 1041 mm)	958 lbs (434.5 kg)
100"x 34" x 54" (2540 x 864 x 1372 mm)	3	21" x 62" (533 x 1575 mm)	1.5"	12.0 gpm (45.4 L/m)	30" x 48" (762 x 1219 mm)	1540 lbs (698.5 kg)
66"x 28" x 54" ** (1676 x 711 x 1372 mm)	2	24" x 72" (610 x 1829 mm)	1.5"	15.0 gpm (56.8 L/m)	39" x 48" (991 x 1219 mm)	2090 lbs (948.0 kg)
82"x 28" x 54" ** (2083 x 711 x 1372 mm)	2	30" x 72" (762 x 1829 mm)	2"	25.0 gpm (94.6 L/m)	39" x 48" (991 x 1219 mm)	3280 lbs (1487.8 kg)

* Non-skidded pre-treatment dimensions are 4" (102 mm) less.

** Skid does not include brine tank. The brine tank is floor mounted.

*** Based on 60 to 90 psi (415 to 620 kPa) inlet pressure.